

ESDEC

INNOVATIVE MOUNTING SYSTEMS



MANUAL CLICKFIT EVO STANDING SEAM ROOF

CLICKFIT EVO

STANDING SEAM ROOF

TABLE OF CONTENTS

Introduction	3
About this document	3
Other relevant documents	3
Symbols used in this manual	3
Warranty and liability	4
Liability	4
Warranty	4
Product information	4
Intended use	4
improper use	4
Specifications	4
Requirements for the work environment	4
System and application	5
Components	5
Application	6
Safety	8
Personal protective equipment	8
Safety warnings and regulations	8
Installation	9
Preparation	9
Cutting mounting rails to required size	11
Fixing the seam clamps	12
Attaching the mounting rails	14
Optional: Attaching the cable clips	15
Mounting the first panel	16
Mounting the following panels	19
Mounting the last panel	21
Mounting multiple rows	23
Dismantling and disposal	23
General	23

INTRODUCTION

ABOUT THIS DOCUMENT

In this manual you will find the installation instructions for the ClickFit EVO mounting system for solar panels on pitched standing seam roofs.

The system is suitable for mounting solar panels in portrait and landscape orientation.

These instructions are addressed at qualified technical personnel.

You can download the latest version of this manual from www.esdec.com.

OTHER RELEVANT DOCUMENTS

When installing the ClickFit EVO mounting system, you will need the following documents:

- The project plan, which you can make in the calculator at www.esdec.com.
- The installation manuals for the solar panels, inverters and any other components.

Always observe the following standards, regulations and rules:

During the installation of the mounting system, it is important to adhere to the installation manual and the accompanying standards to prevent accidents. Pay special attention to (local) standards, regulations and legislation (among others):

- The Building Regulations 2010 (latest version)
- Health and Safety at Work etc Act 1974
- Health and Safety in Roof work - HSE
- Eurocodes 0 (EN 1990 - Structural Design)
- Eurocodes 1 (EN 1991 - Influences on structures)
- HD-IEC 60363 series - Electrical installations for low voltage
- EN-IEC 62305-2 - Protection lightning - Risk Management
- MIS 3002 - The solar PV standard
- MCS012 - Product Certification Scheme Requirements: Pitched Roof Installation Kits



EARTHING AND BONDING

Our ClickFit EVO systems are VDE certified for corrosion and bonding. According to the electrical standard HD-IEC 60364 – chapter 712, functional bonding for inverter’s isolation check is necessary.

In the Esdec ClickFit EVO Series functional bonding is achieved through the EVO universal module clamp for the module frames and EVO rails. The final functional bonding connection is made by proper mounting of a separate bonding cable onto the EVO rail and an adequate bonding connection with the inverter or earthing contact.

For detailed instructions on grounding and bonding, consult the electrical standard HD-IEC 60364 and any local regulations. Please, follow the instructions of the inverter’s manual. This operation needs to be done by a certified electrician.

SYMBOLS USED IN THIS MANUAL

	Warning!	Failure to follow this instruction could result in serious injury or major damage to the product.
	Caution!	Failure to follow this instruction could result in personal injury or damage to the product.
	Note	Emphasises an instruction.

WARRANTY AND LIABILITY

LIABILITY

The manufacturer accepts no liability for damage or injury caused by the failure to comply (strictly) with the safety guidelines and instructions in this manual, or by negligence during installation of the product and the accessories listed in this document.

Esdec BV reserves the right to change this document without notice.

WARRANTY

Esdec extends a 20 year product warranty. The warranty is subject to the warranty terms and general terms & conditions of Esdec BV. These can be found on the www.esdec.com website.

PRODUCT INFORMATION

INTENDED USE



The ClickFit EVO mounting system is designed for mounting solar panels on pitched standing seam roofs. With this mounting system, solar panels can be positioned on the roof either with the short side at the bottom (portrait) or with the long side at the bottom (landscape).

IMPROPER USE



The mounting system is not suitable for use on types of roof other than the one specified.

SPECIFICATIONS

Orientation of solar panels	Portrait and landscape	
Frame height of solar panel	29 - 50mm	
Maximum area of solar panels	2.6m ²	
Maximum field size	Horizontal rails: 6.15m per segment	Vertical rails: 15m per segment
Roof type	Pitched roof with seams, except copper roofs	
Roof pitch	The seam clamps can be mounted with a roof pitch between 5 and 60°.	
Maximum roof height	Subject to Eurocode guidelines and national additions. Use the calculator to calculate the possibilities of your project.	
Edge zone	30cm distance to the ridge, 30cm to the side of the roof and 30 cm to the gutter.	

-  Enter the data in the calculator, so you are sure of choosing the right system for the terrain category, snow loads and wind zone that applies to your project.
-  Depending on the roof and the result obtained from the calculator, you can lay several segments with solar panels next to each other. Always leave a minimum of 25mm of space between segments to allow for expansion of the roof.
-  If your project has different specifications than these, please contact Esdec.

REQUIREMENTS FOR THE WORK ENVIRONMENT

	The roof is in good condition.
	The roof construction has sufficient bearing capacity to support the installation, taking into account wind and snow loads.

SYSTEM AND APPLICATION

1 COMPONENTS

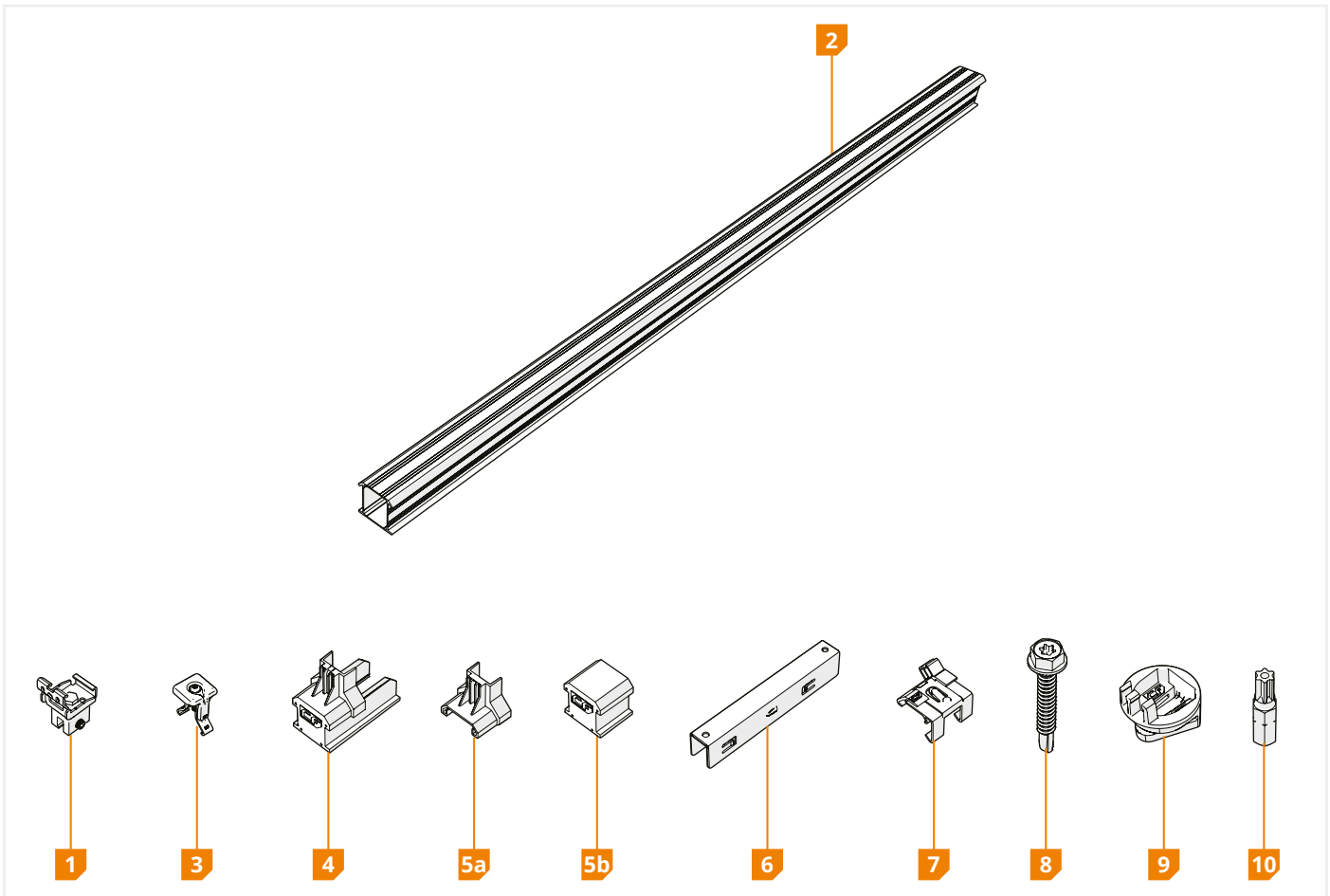

COMPONENT	ARTICLE NUMBER
1 ClickFit EVO Seam Clamp	100803_
2 ClickFit EVO Mounting Rail	10081_ _
3 ClickFit EVO Module Clamp universal	1008020(-B)
4 ClickFit EVO Mounting Rail End Cap	1008060(-B)
5 a. ClickFit EVO End Clamp Support	1008065(-B)
b. ClickFit EVO End Cap without end clamp support	1008066(-B)

ACCESSORY	ARTICLE NUMBER
6 ClickFit EVO Mounting Rail Coupler	1008061
7 ClickFit EVO Cable Clip Optimiser Ready	1008062
8 ClickFit EVO Self-drilling screw 6,3x42mm SW10/T30	1003016
9 ClickFit EVO mounting set	1008064
10 ClickFit EVO Screw Bit Torx 30	1008069

i Check that the correct components are present in the required numbers according to the project plan generated by the calculator.

SEAM CLAMP

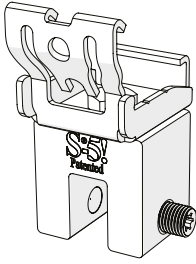
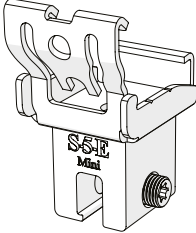
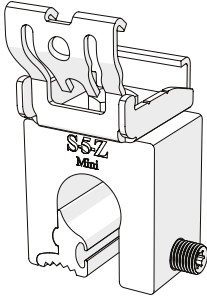
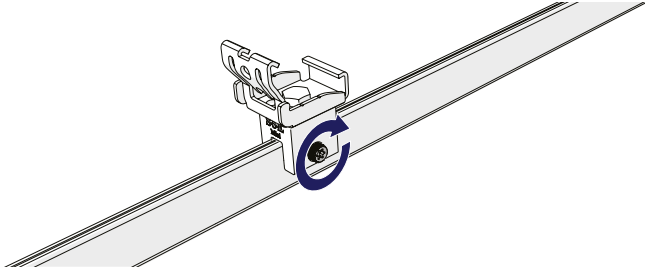
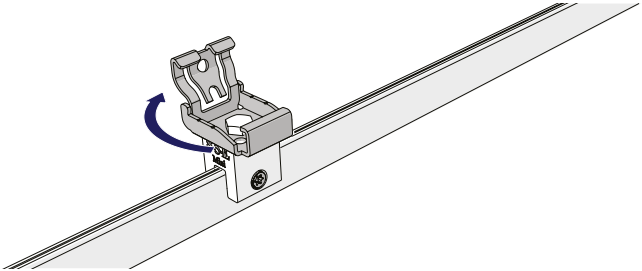
			
Article number	1008035	1008033	1008031
Suitable for	Single-folded standing seam roof Snap seam roof	Double-folded standing seam roof	Round standing seam roof
Seam opening	14mm	9mm	ø 23mm
			
Fixing	Directly on the seam		
			
Click connection	Rotatable for horizontal and vertical mounting of rails		

HORIZONTAL RAIL ORIENTATION

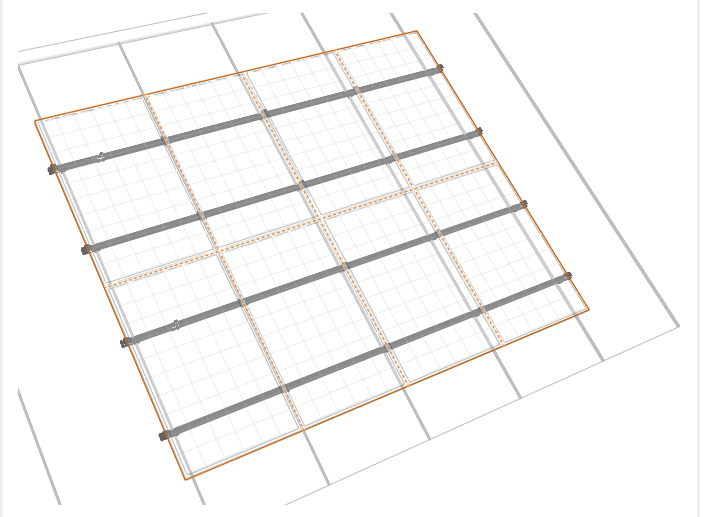
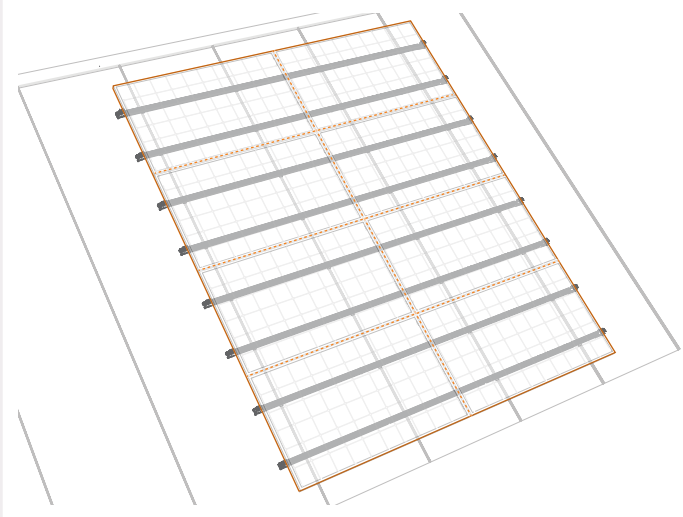

VERTICAL RAIL ORIENTATION

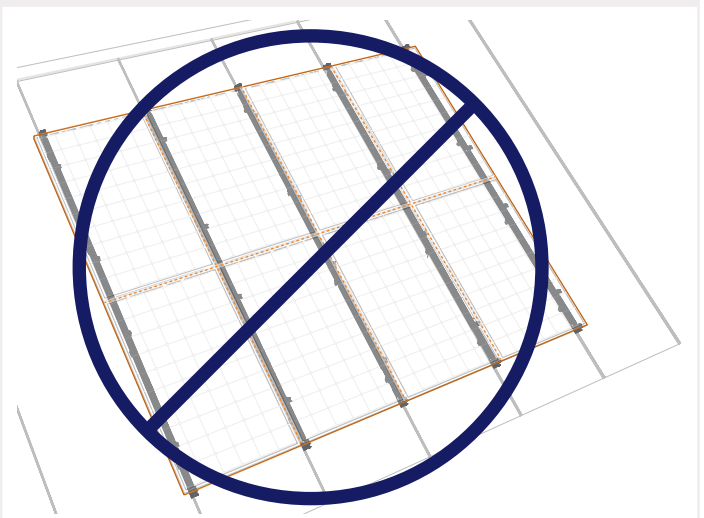
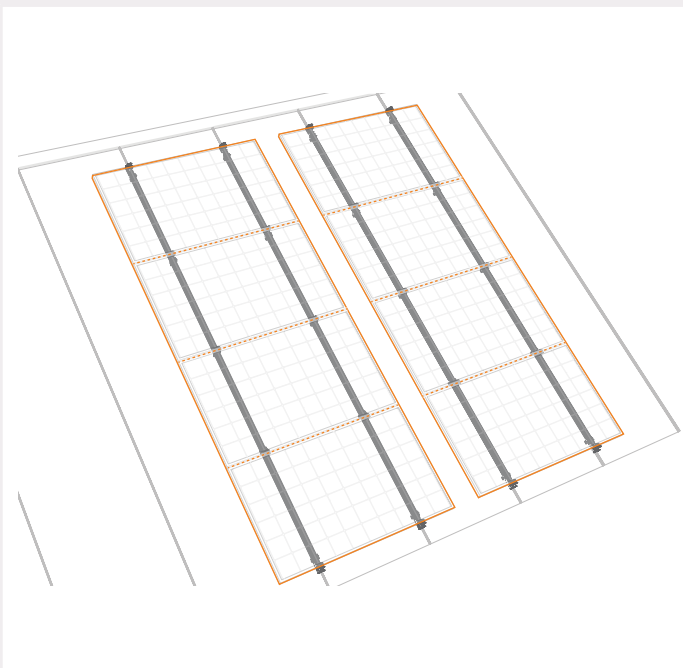

! Mounting solar panels in portrait orientation in combination with vertical rail orientation is not recommended. This mounting method is also not supported by the calculator.

- ! The distance from the edge of solar panels to both the ridge and the gutter must be at least 30cm.
- ! The distance from the solar panels to the side of the roof must be at least 30cm.
- ! Clamping the solar panels on the short side is not recommended.

PERSONAL PROTECTIVE EQUIPMENT

						
Hearing protection	Safety helmet	Safety glasses	Face masks	Safety gloves	Safety clothing	Safety shoes

SAFETY WARNINGS AND REGULATIONS

Warning!

- ⚠ Installation work should always be carried out by at least two skilled people.
- ⚠ Do not use components from other mounting systems.
- ⚠ Do not leave out parts.
- ⚠ Always work according to the current regulations for working on roofs.
- ⚠ Do not perform the installation in strong winds, or when the roof is slippery or wet.
- ⚠ Always work on the roof with fall protection and, if necessary, with safety nets and edge protection.
- ⚠ Never stand on or in the gutter.
- ⚠ Make sure that an aerial platform or ladder does not rest on the seams.
- ⚠ Always use a lifting aid or hoisting device when moving heavy equipment.
- ⚠ Always place ladders on a strong, stable surface.



Caution!

- ⚠ Walk as little as possible on the roof. Use an aerial platform, ladder or other solution.
- ⚠ Never walk on the system or on the solar panels.



INSTALLATION

1 PREPARATION

1 INSPECT THE ROOF

-  The roof is in good condition.
-  The roof construction has sufficient bearing capacity to support the installation, taking into account wind and snow loads.

2 CHECK THE PROJECT PLAN AND COMPONENTS

-  Check the project plan. Is there no project plan? Then create one in the online calculator before starting installation.
-  Check that all components are present (page 5).

3 MAKE SURE ALL THE REQUIRED TOOLS ARE AT HAND

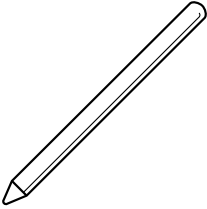
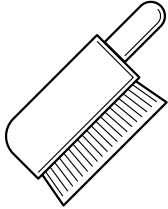
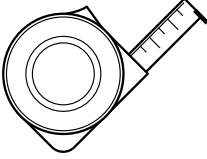
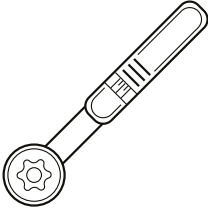
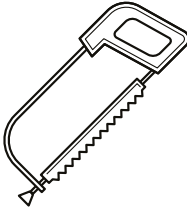
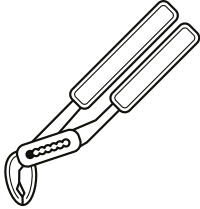
					
Marker or chalk	Brush	Tape measure	Torque wrench up to 20Nm with TX 30 safety bit	Hacksaw	Adjustable pliers

4 CLEAN THE ROOF SEAMS

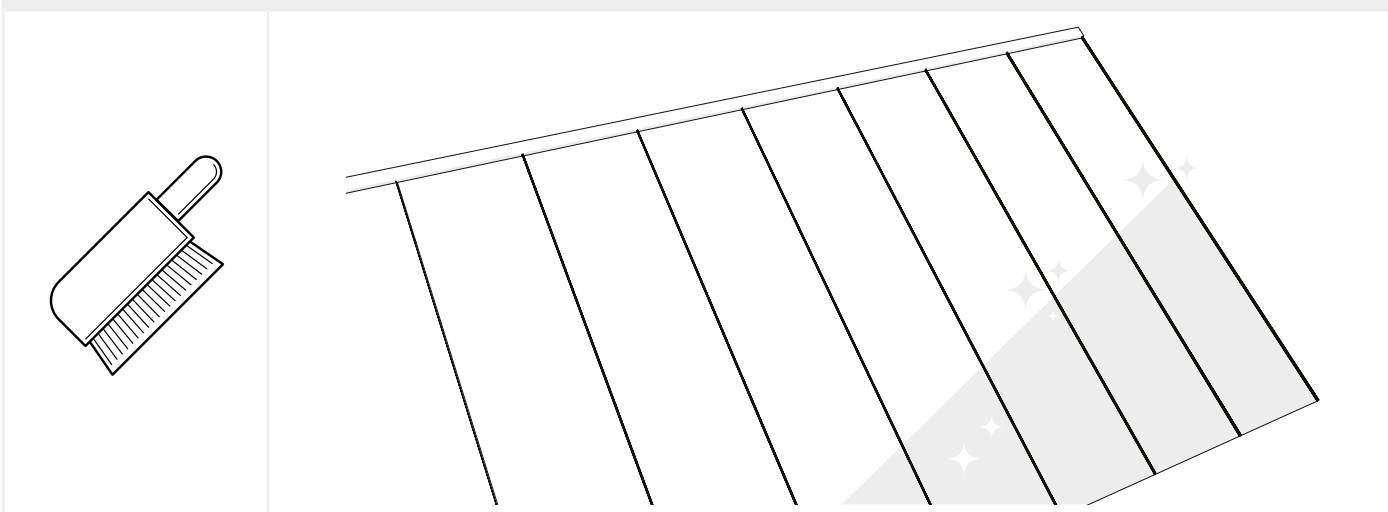

5 DETERMINE THE POSITION OF THE SOLAR PANELS ON THE ROOF

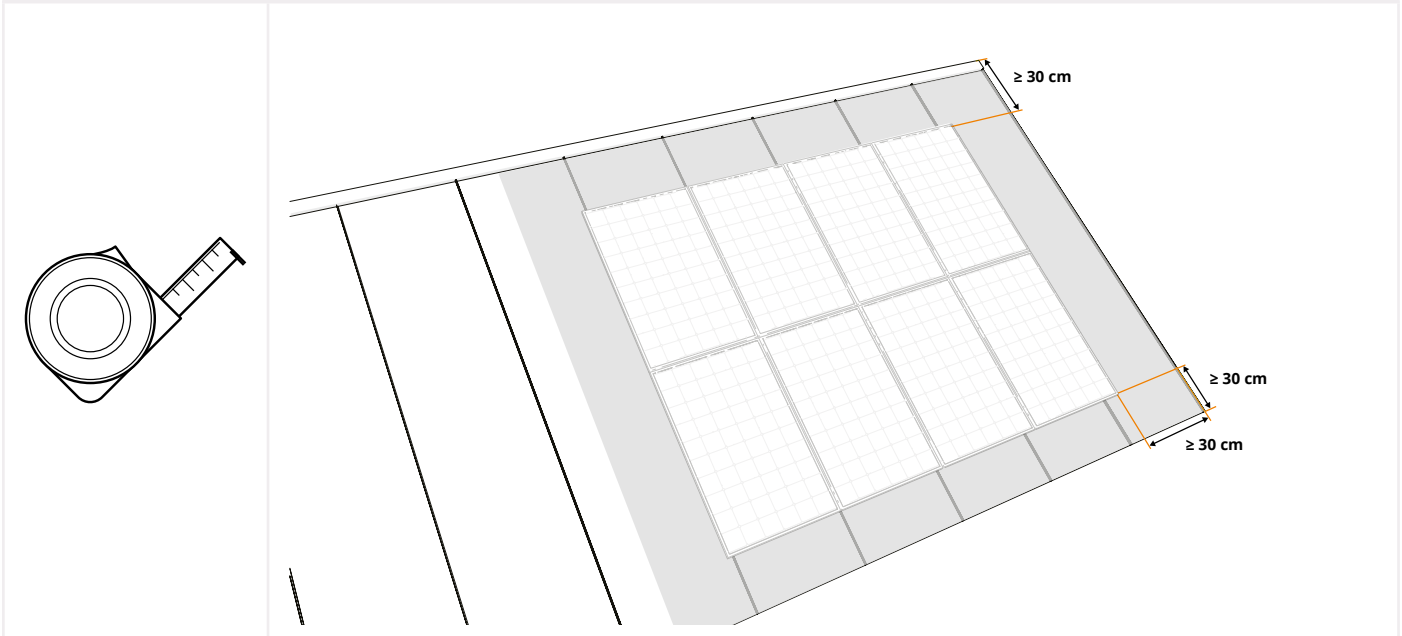

- i** Take into account sunlight and shade over the whole year. Apply power optimizer to get the most out of your installation.

6 DRAW THE LINES AND END POINTS FOR THE MOUNTING RAILS

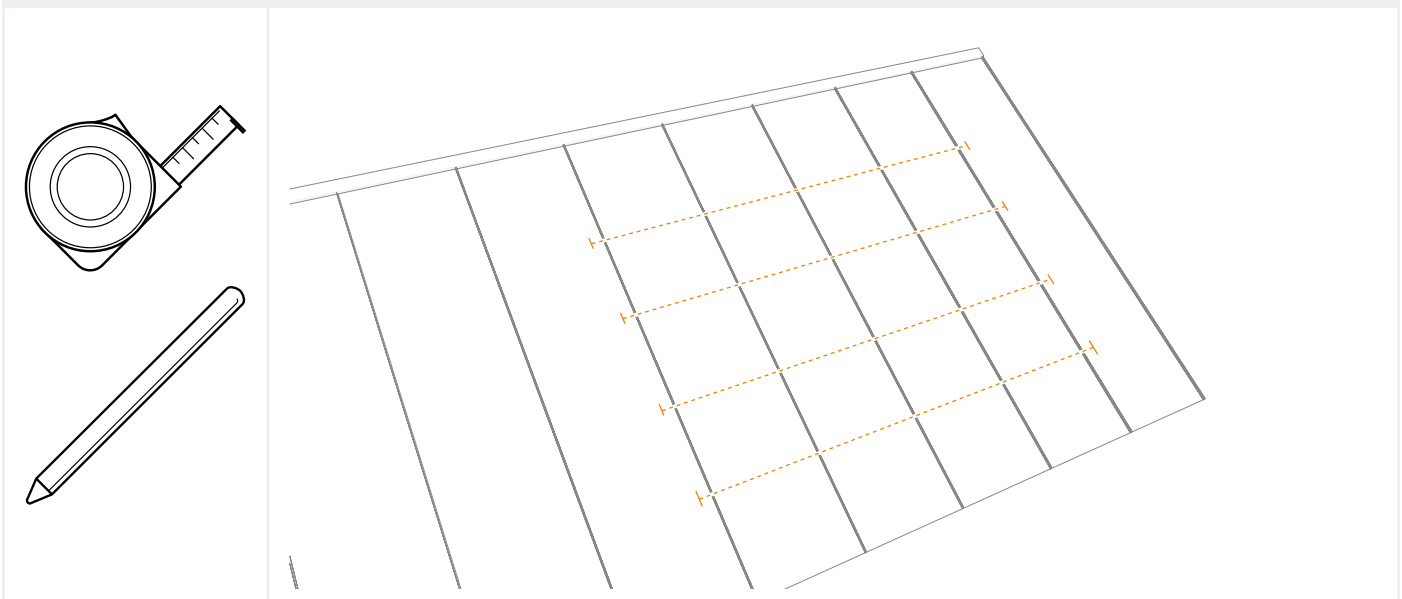

- i** Consult the project plan to determine the position of the mounting rails for your panel.
- i** For pitched roofs, we recommend a horizontal mounting. This is more durable and often creates a neater finish.

7 MARK THE POSITION OF THE SEAM CLAMPS

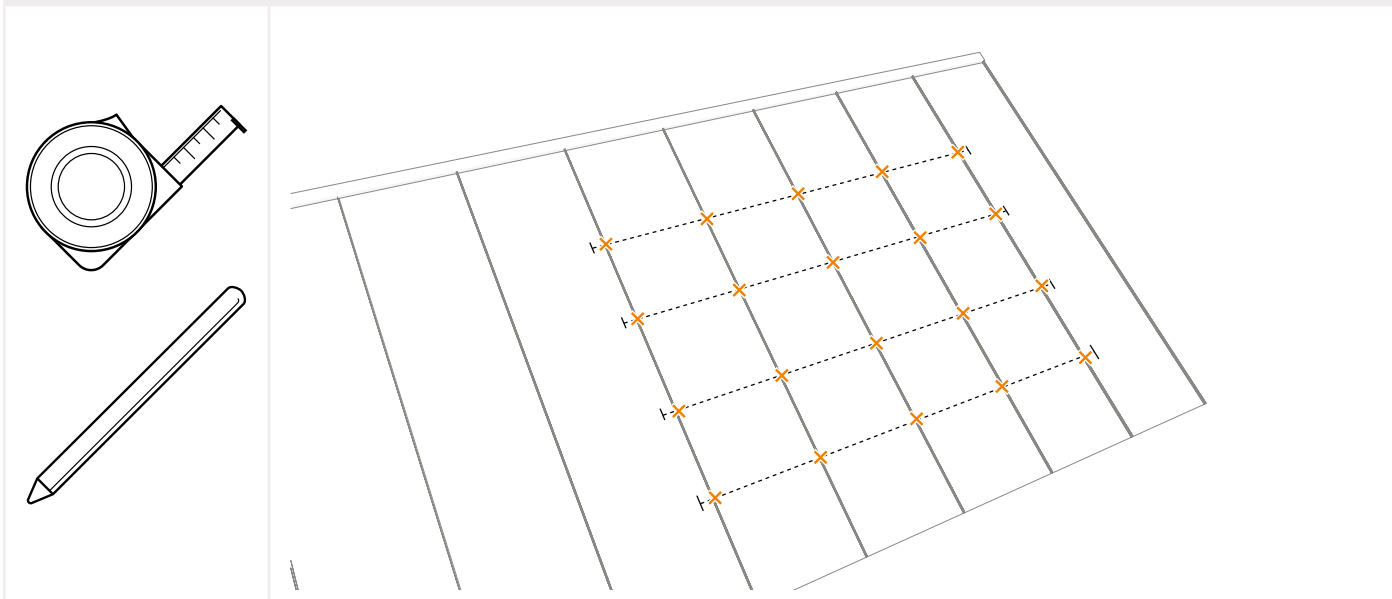

- ⚠ If you are not sure about the strength of the roof, we advise you to have this checked by an expert/the supplier of the standing seam roof. A standing seam roof is always subject to expansion or contraction due to temperature fluctuations.
- ⚠ If you can see the position of the standing seam clips, mount the seam clamps at least 50mm away.
- ℹ Consult the project plan to determine the position of the seam clamps for your project.

2 CUTTING MOUNTING RAILS TO REQUIRED SIZE

1 DETERMINE THE LENGTH OF THE MOUNTING RAILS BASED ON THE SOLAR PANELS

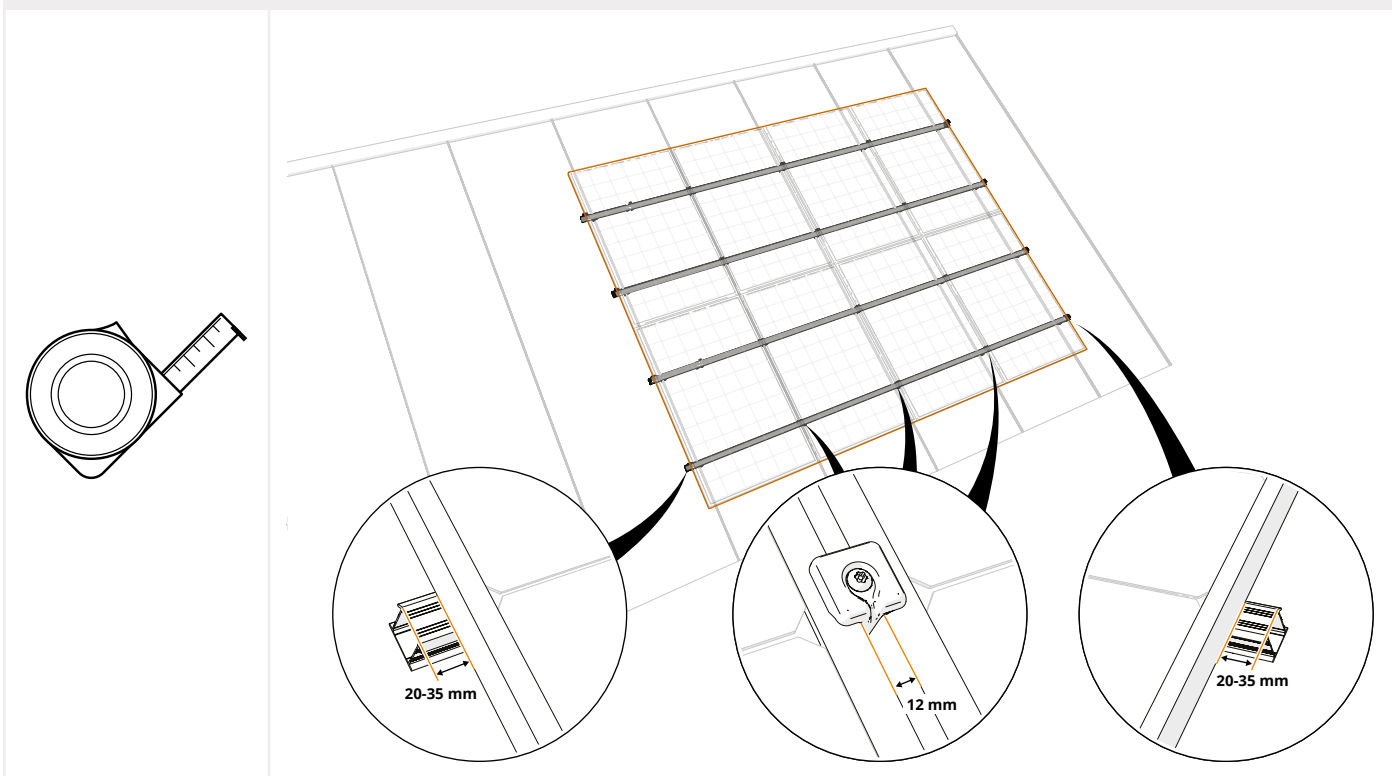

- ℹ Calculate the minimum length of the mounting rails: $(\text{panel size} + 12 \text{ mm}) \times \text{number of panels} - 12 \text{ mm} + (2 \times 30 \text{ mm})$

2 OPTIONAL: USE COUPLERS TO CONNECT THE MOUNTING RAILS

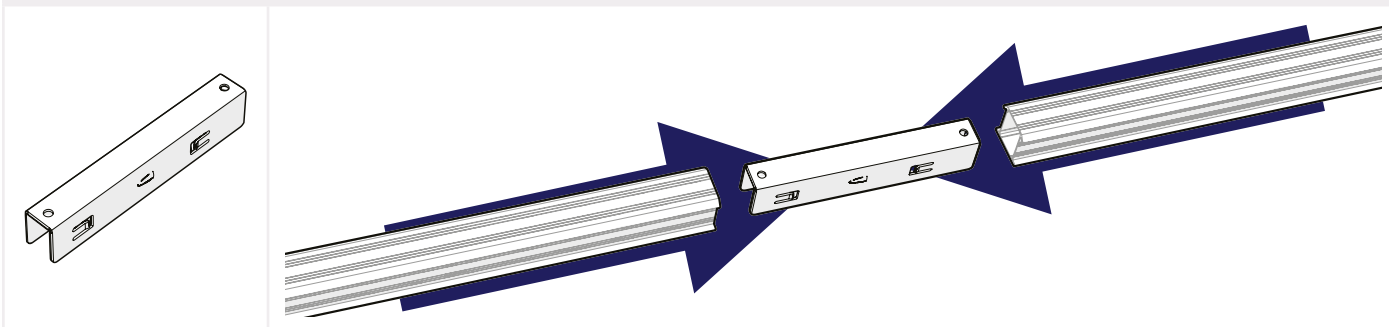

3 OPTIONAL: EXTEND THE MOUNTING RAIL TO THE NEXT SEAM

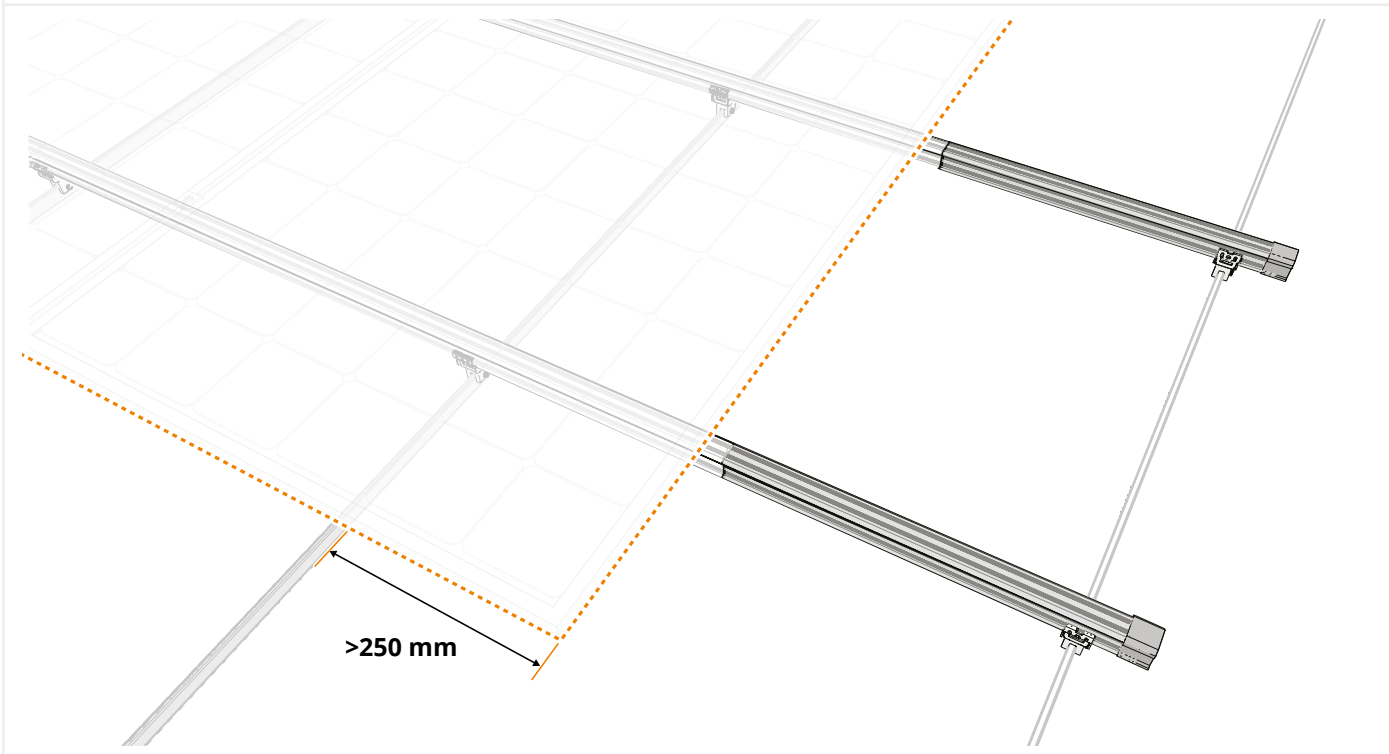

- i** If the outer panel edge is more than 250 mm outside the first/last seam, extend the mounting rail to 50 mm beyond the previous/next seam and provide a seam clamp here for attachment. The extra 50 mm facilitates sufficient length to accommodate the mounting rails of the end cap (art. no. 1008066(-B)). At the location of the end clamp, you must provide the end clamp support (art. no. 1008065(-B)).

3 FIXING THE SEAM CLAMPS

1 PLACE THE CLAMP ON THE SEAM

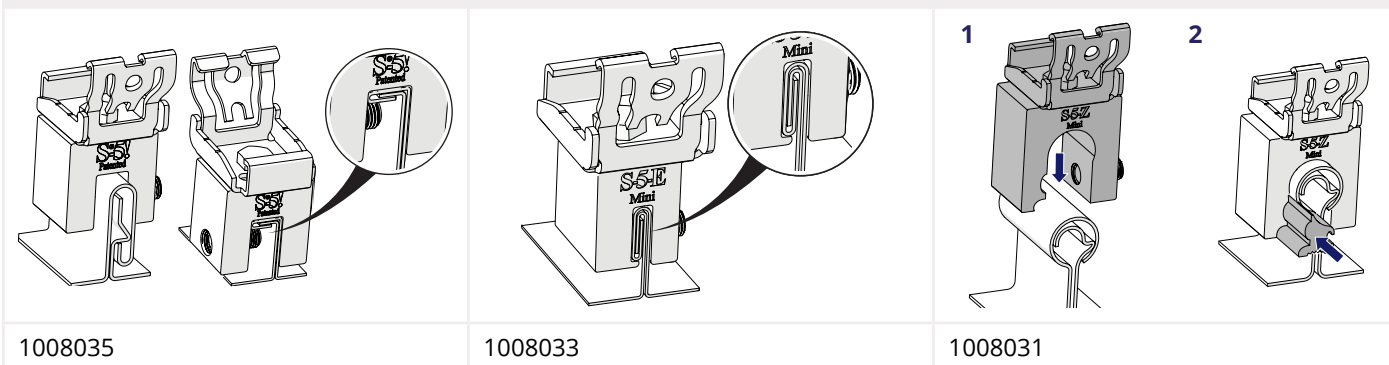

2 TIGHTEN THE SCREW

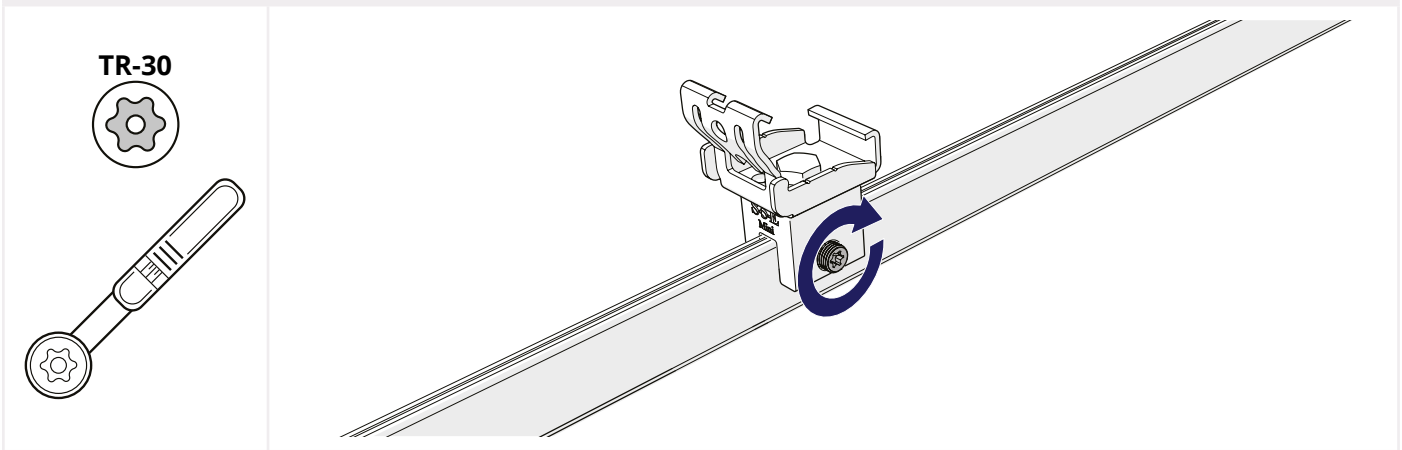

General tightening torque

15 - 17 Nm

Tightening torque for steel standing seam roofs with material thickness > 0.7 mm

18 - 20 Nm

- ⓘ Always use a torque wrench. Make sure that the bit is correctly and completely inserted in the screw head when tightening, in view of the high tightening torque.

3 ROTATE THE CLICK CONNECTION INTO THE CORRECT ORIENTATION

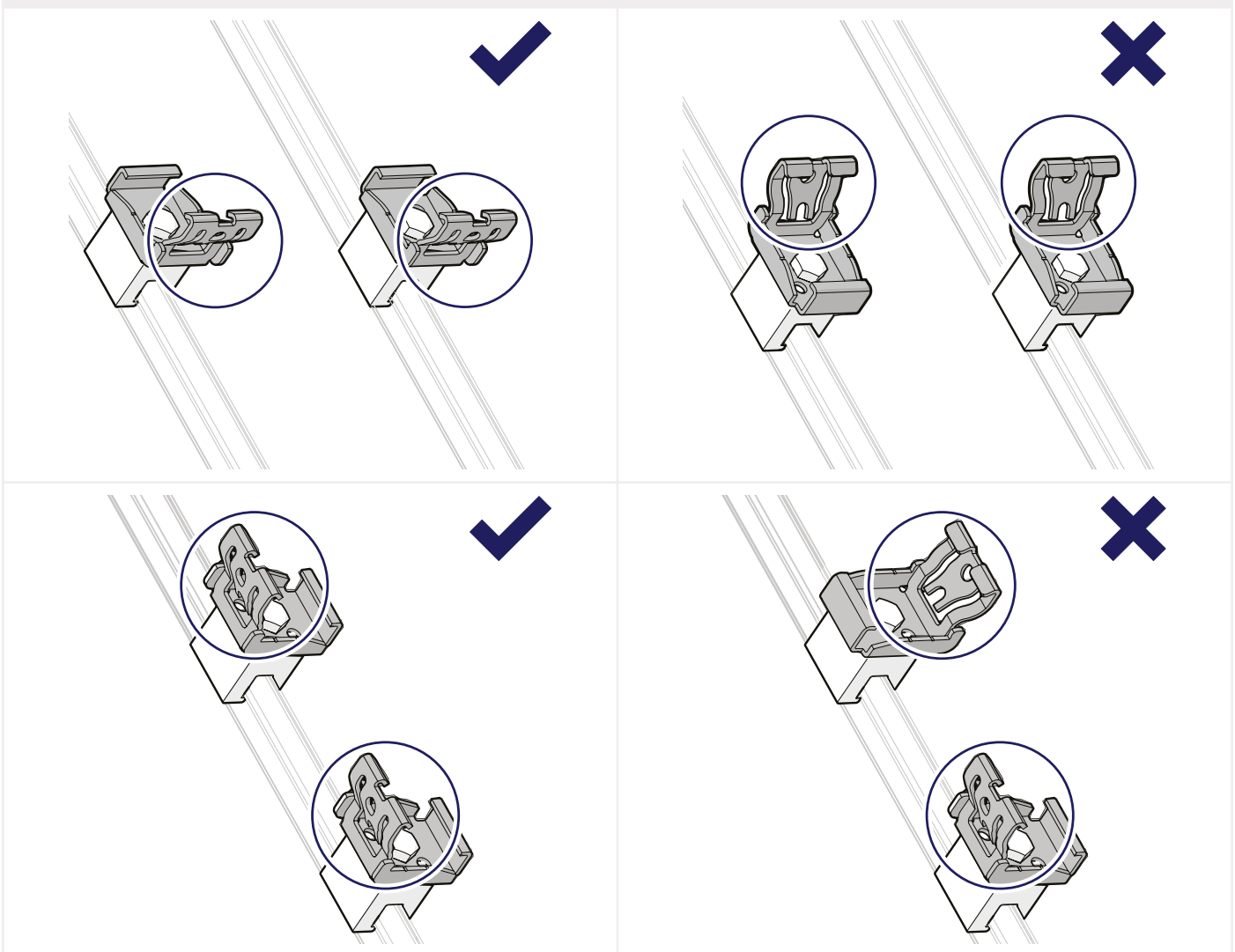

4

ATTACHING THE MOUNTING RAILS

1 PLACE THE MOUNTING RAIL INTO THE CLICK CONNECTION AND ALIGN THEM

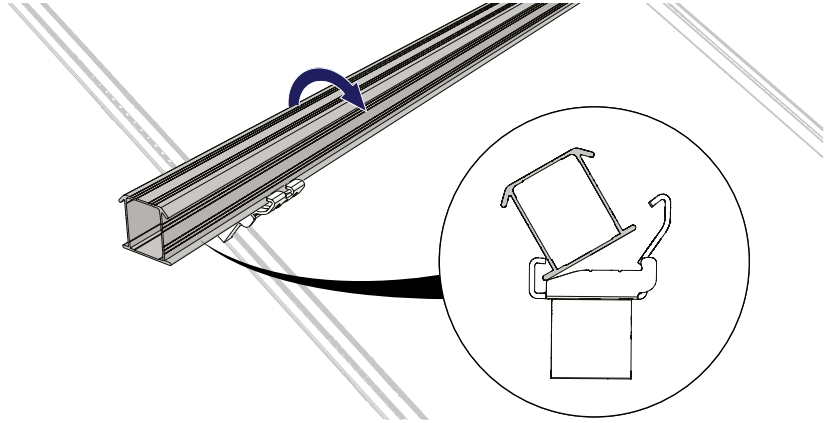

2 CLICK IN THE MOUNTING RAILS

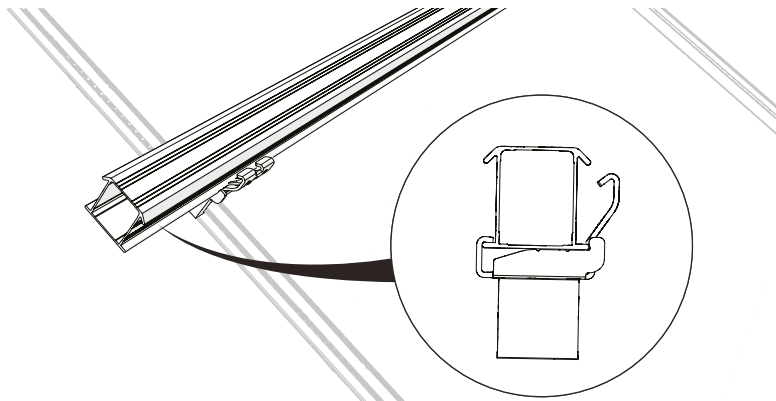

3 FOR VERTICAL MOUNTING: SECURE THE MOUNTING RAILS TO THE CLICK CONNECTIONS

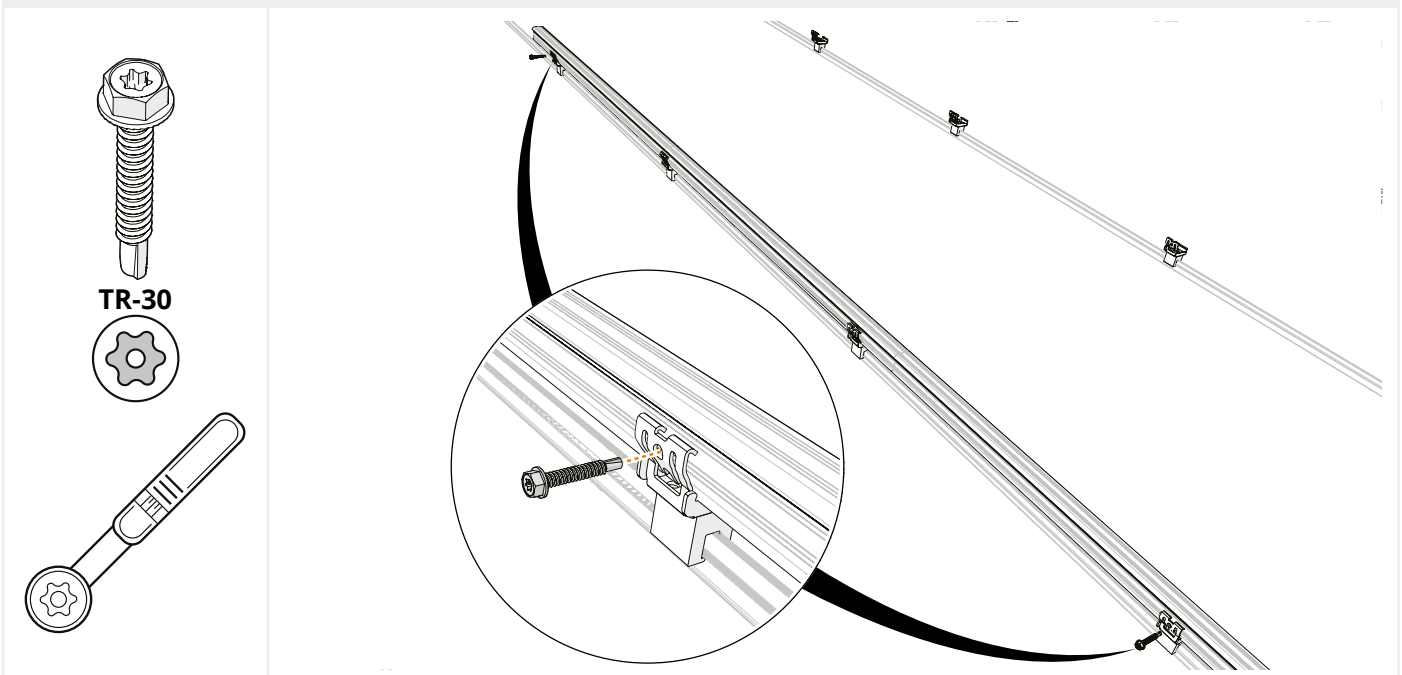

i Secure the bottom click connection with a self-drilling screw. Skip two click connections and then screw down the fourth click connection. Repeat until the top click connection.

5

OPTIONAL: ATTACHING THE CABLE CLIPS

1 CLICK THE CABLE CLIP ONTO THE RAIL

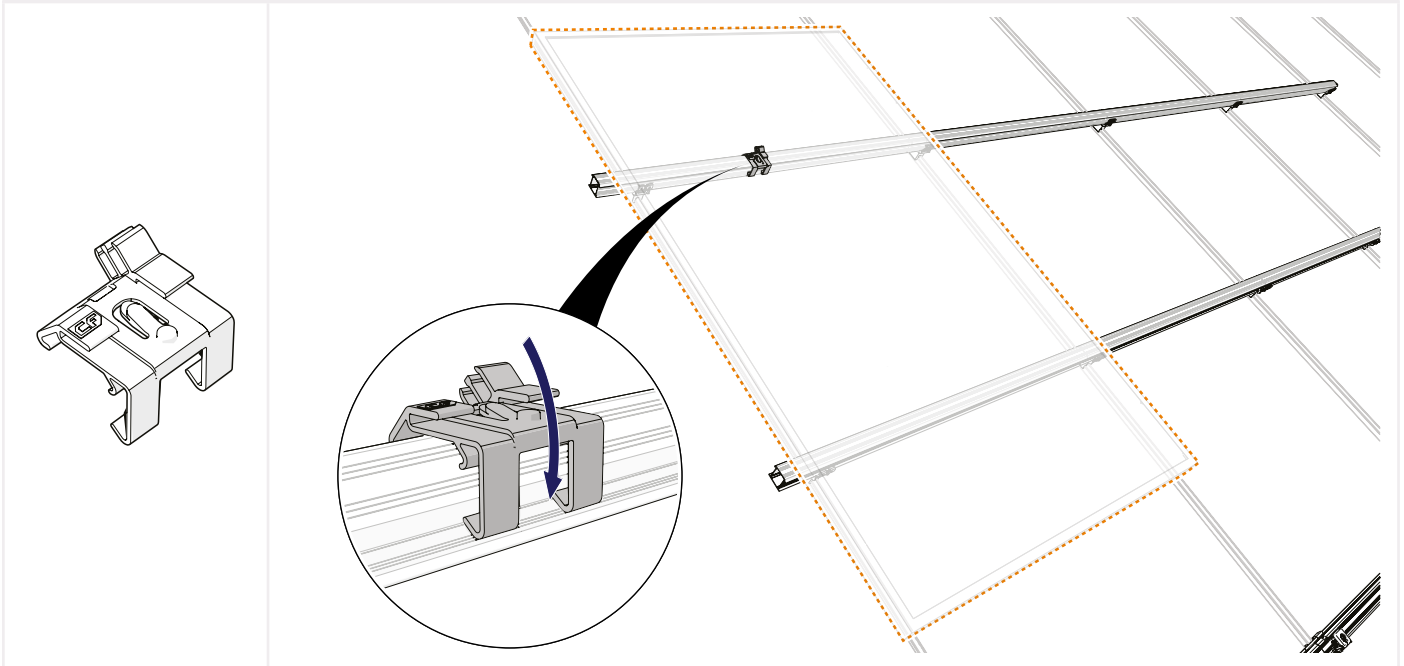

i Use one cable clip per solar panel.

2 GUIDE THE CABLE THROUGH THE CLICK CONNECTION AND THE CABLE CLIP

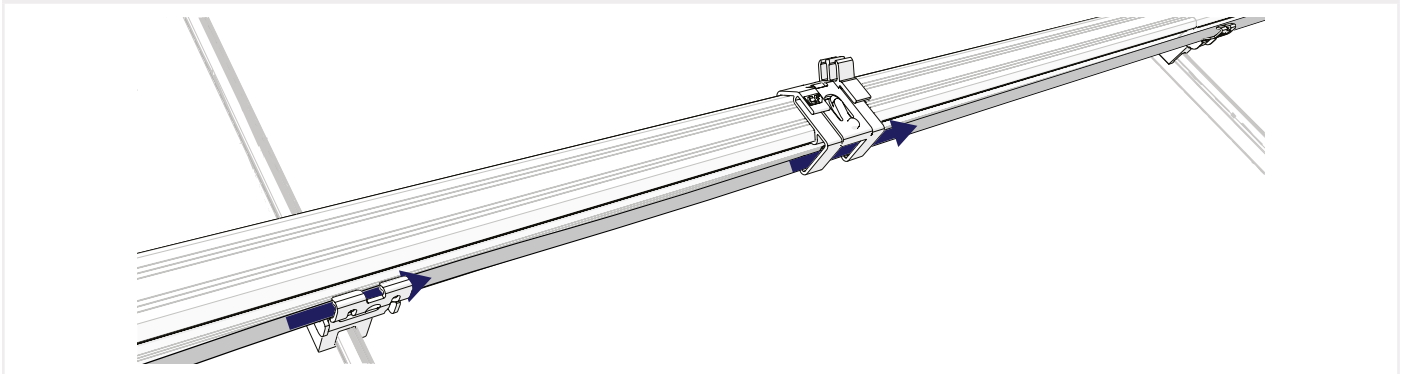

3 OPTIONAL: CLICK THE OPTIMISER ON THE CABLE CLIP

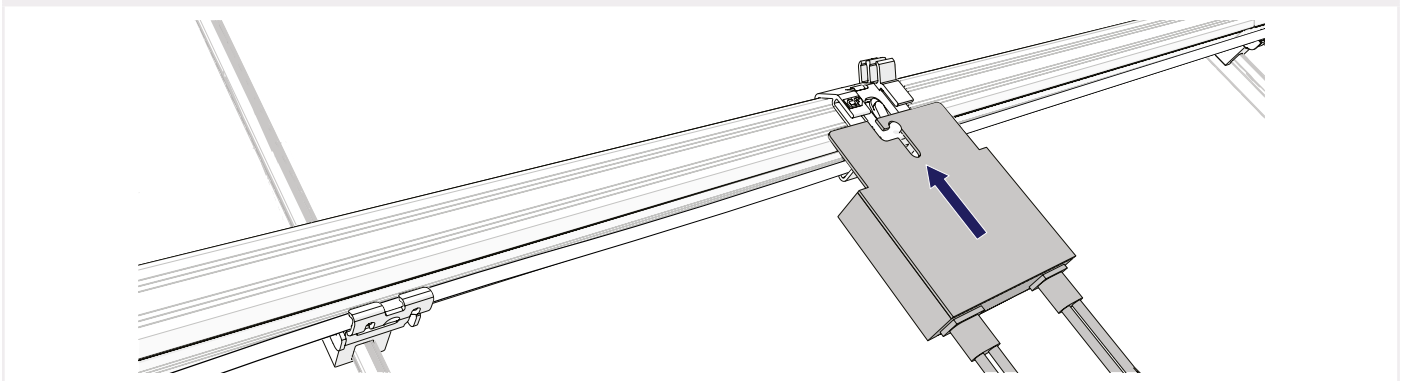

i With vertical rail orientation you have to fix the cable clip by bending the edge of the mounting rail with adjustable pliers.

6 MOUNTING THE FIRST PANEL

1 OPTIONAL: CLICK THE AUXILIARY SETON THE PANEL

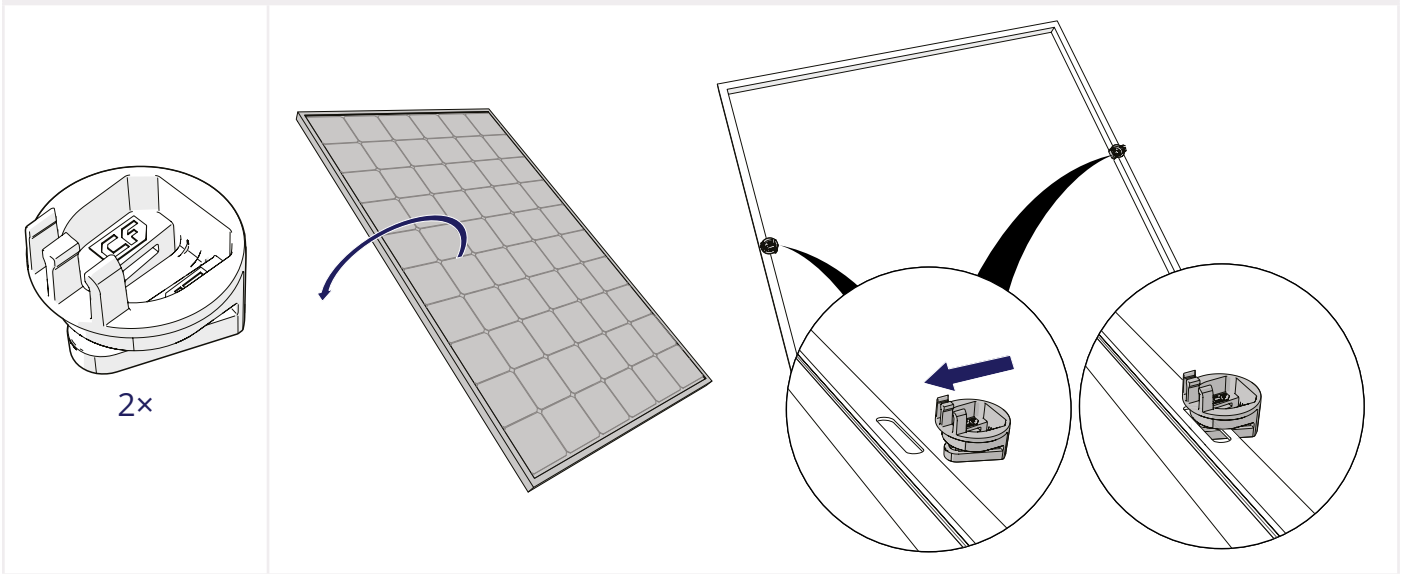

2 OPTIONAL: CLICK THE CABLES OF THE PANEL FIRMLY INTO THE CABLE CLAMP

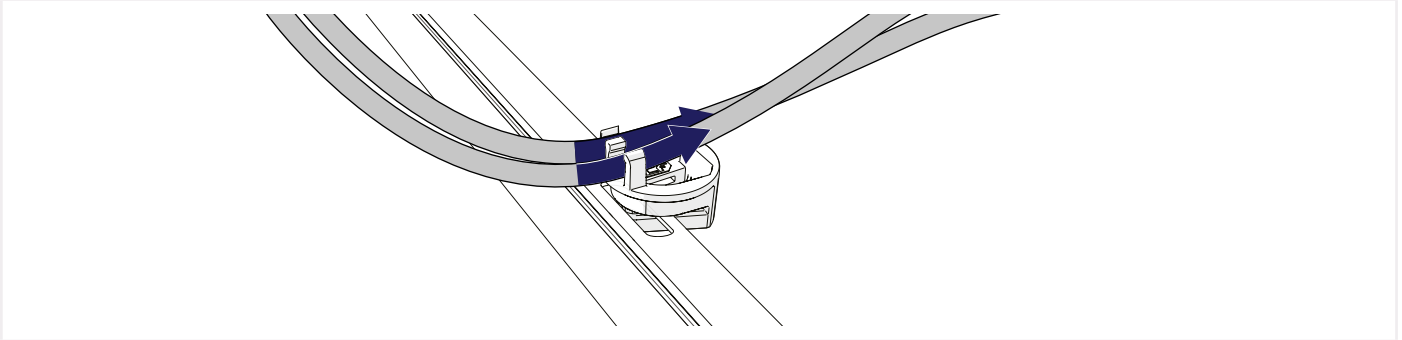

3 CLICK THE UNIVERSAL MODULE CLAMP ON THE RAILS

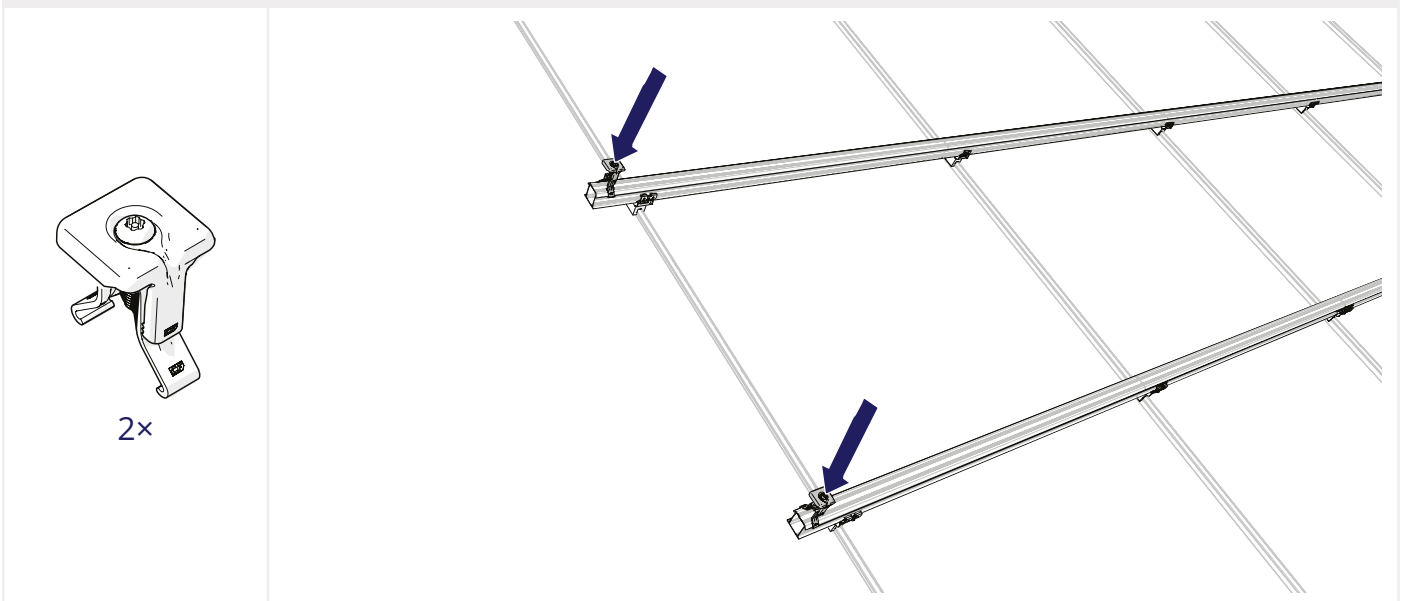

4 SLIDE THE END CAPS ONTO THE RAILS

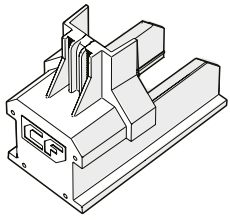

2x

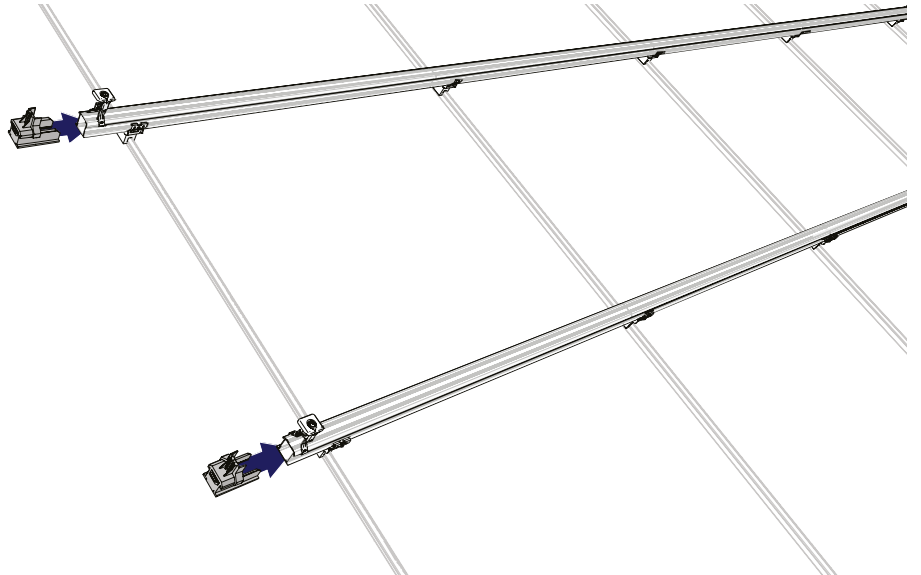

5 ROTATE THE UPPER PART OF THE MODULE CLAMP OVER THE END CAP

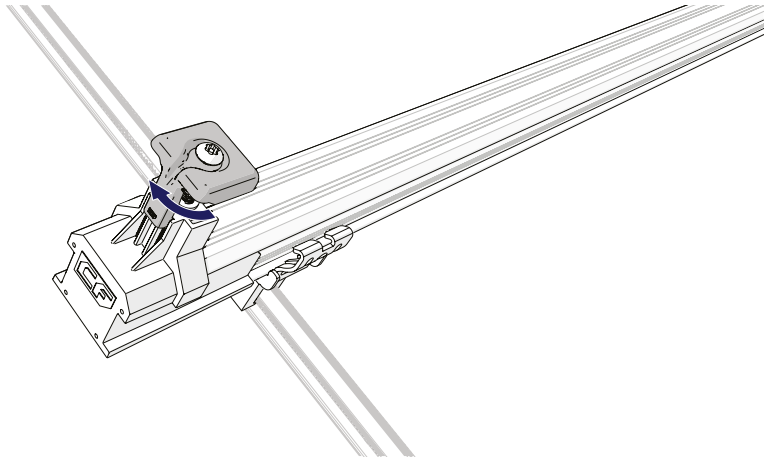

6 PLACE THE PANEL ON THE RAILS

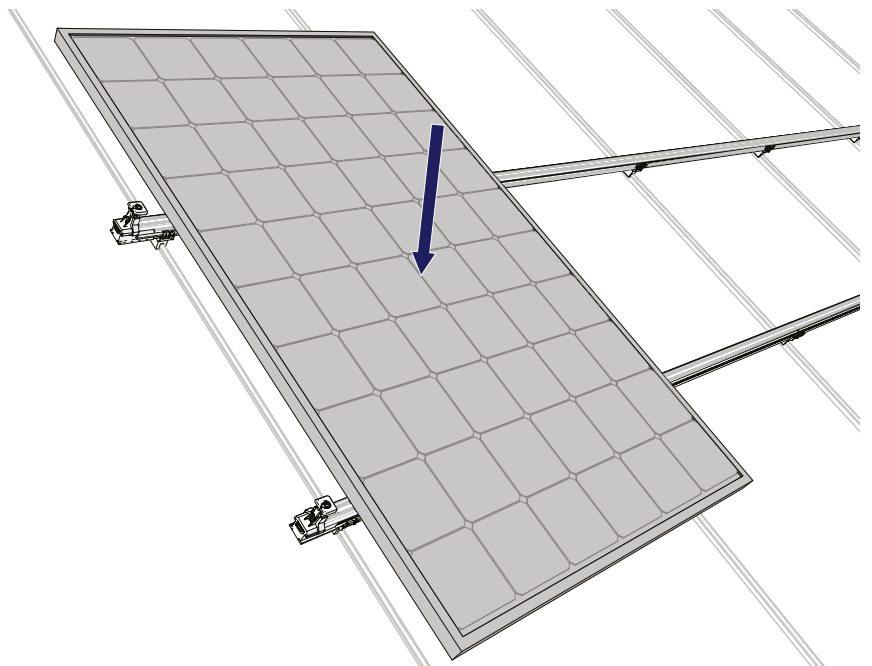
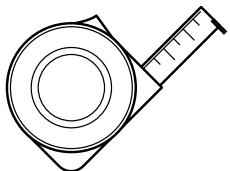

7 OPTIONAL: CLICK THE CABLES OF THE PANEL IN THE CABLE CLIP

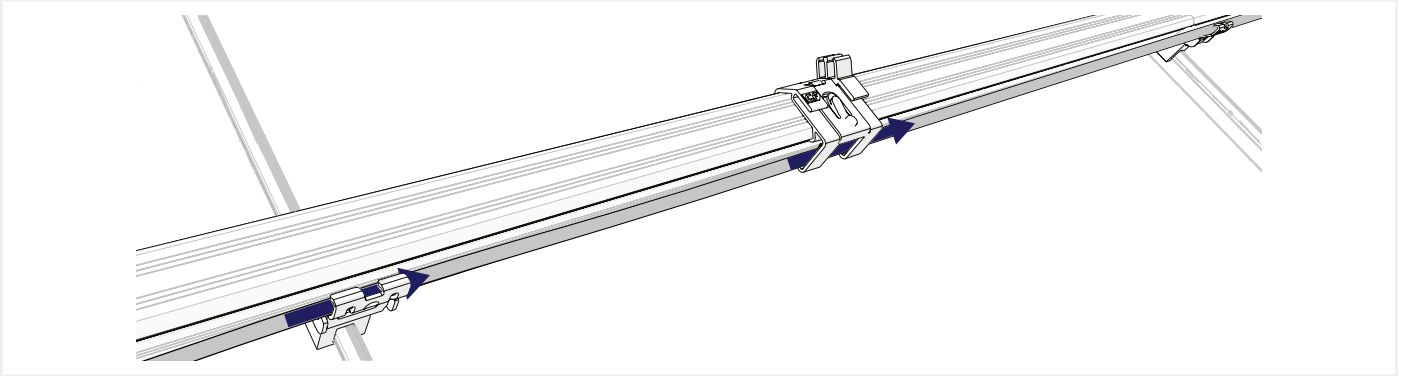

8 SLIDE THE PANEL AGAINST THE CLAMPS

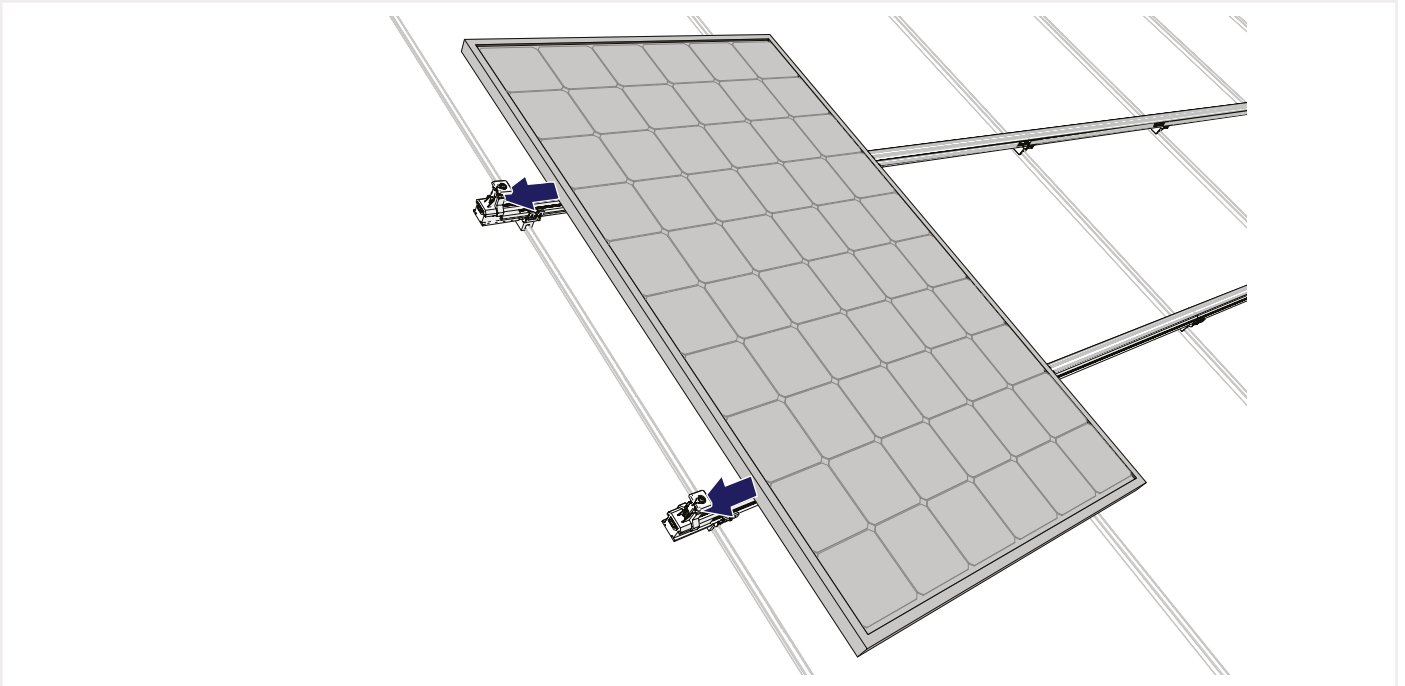

9 SCREW THE CLAMPS ONTO THE PANEL

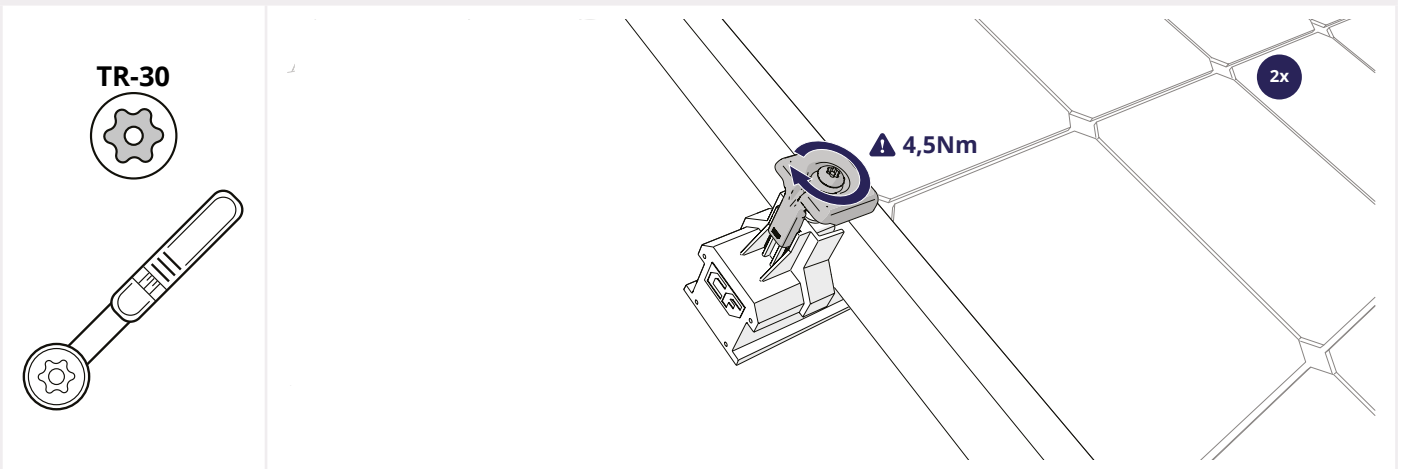

7 MOUNTING THE FOLLOWING PANELS



Optional: Repeat steps 6.1. Click the Auxiliary seton the panel and 6.2. Click the cables of the panel firmly into the cable clamp.

1 CLICK THE UNIVERSAL MODULE CLAMP ON THE RAILS

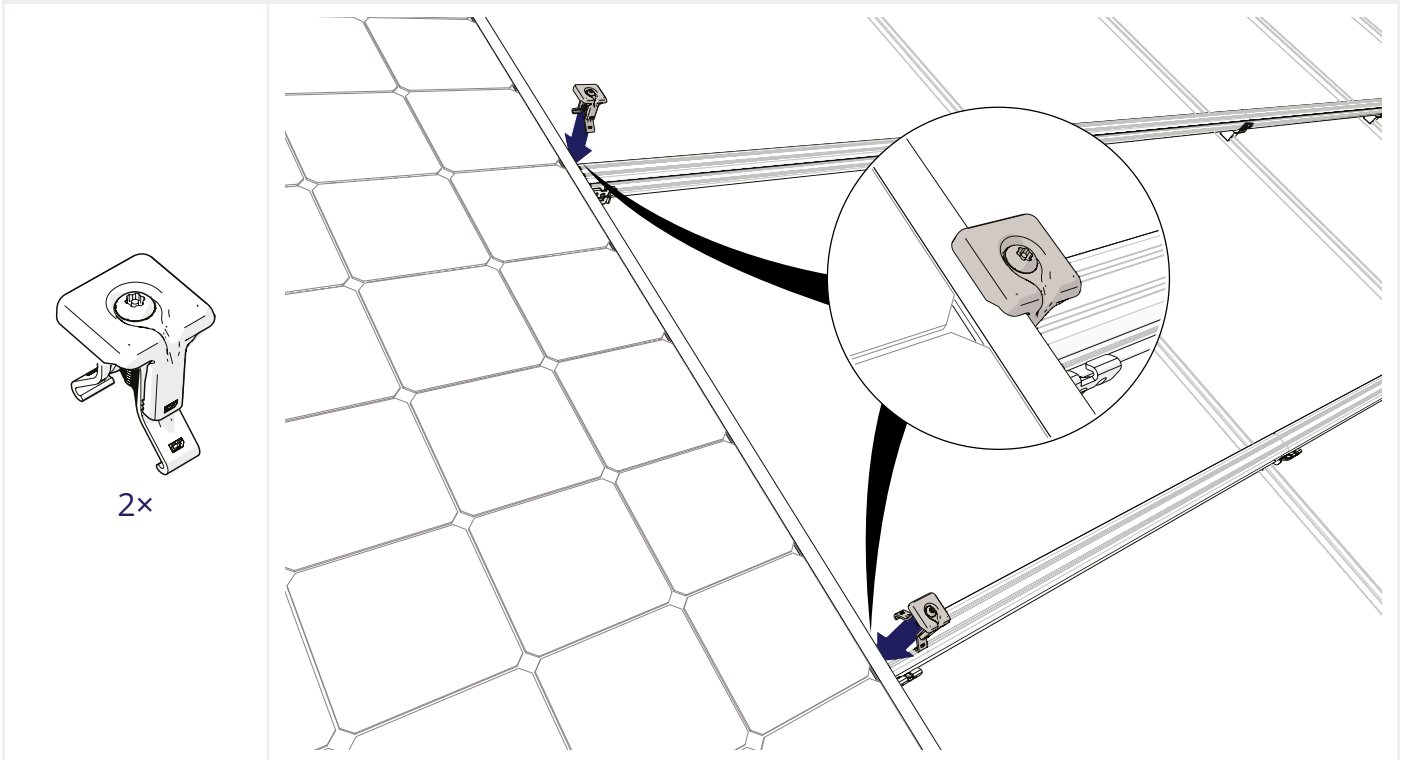

i Install the module clamp with the drainage channel of the module clamp pointing downwards.



Repeat step 6.6. Place the panel on the rails

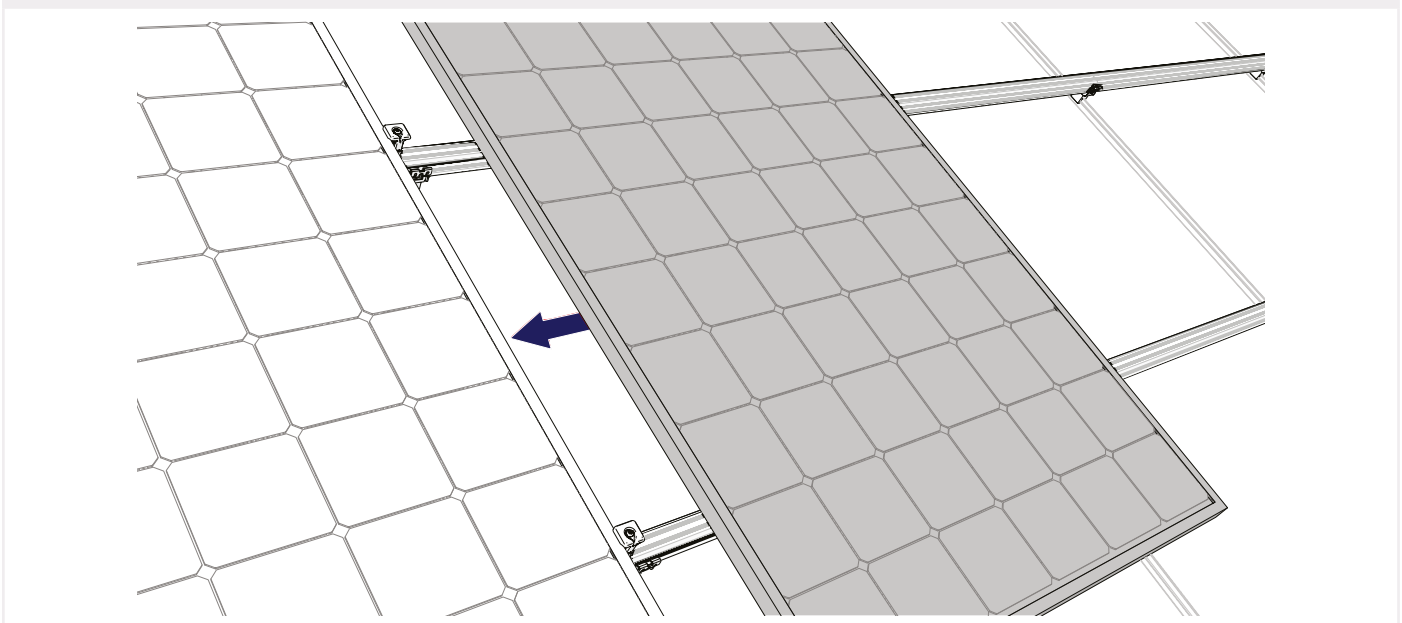

2 SLIDE THE PANEL AGAINST THE CLAMPS



3 SCREW THE CLAMPS ONTO THE PANEL

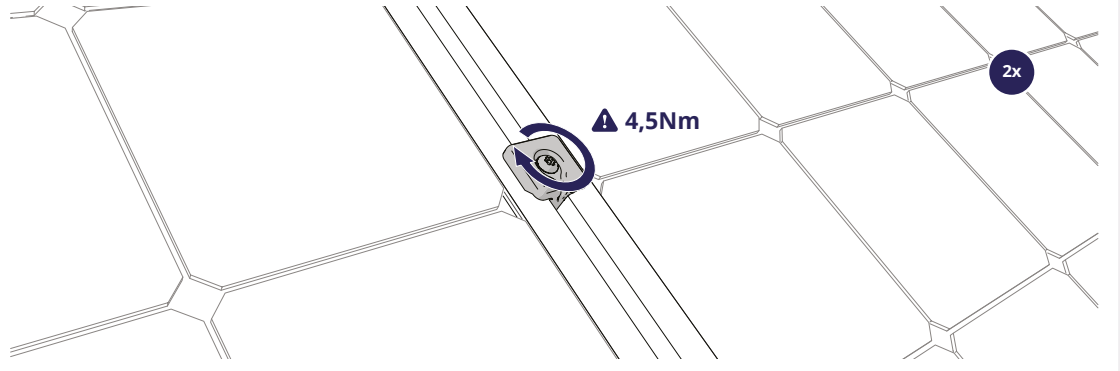
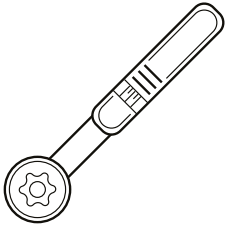

TR-30

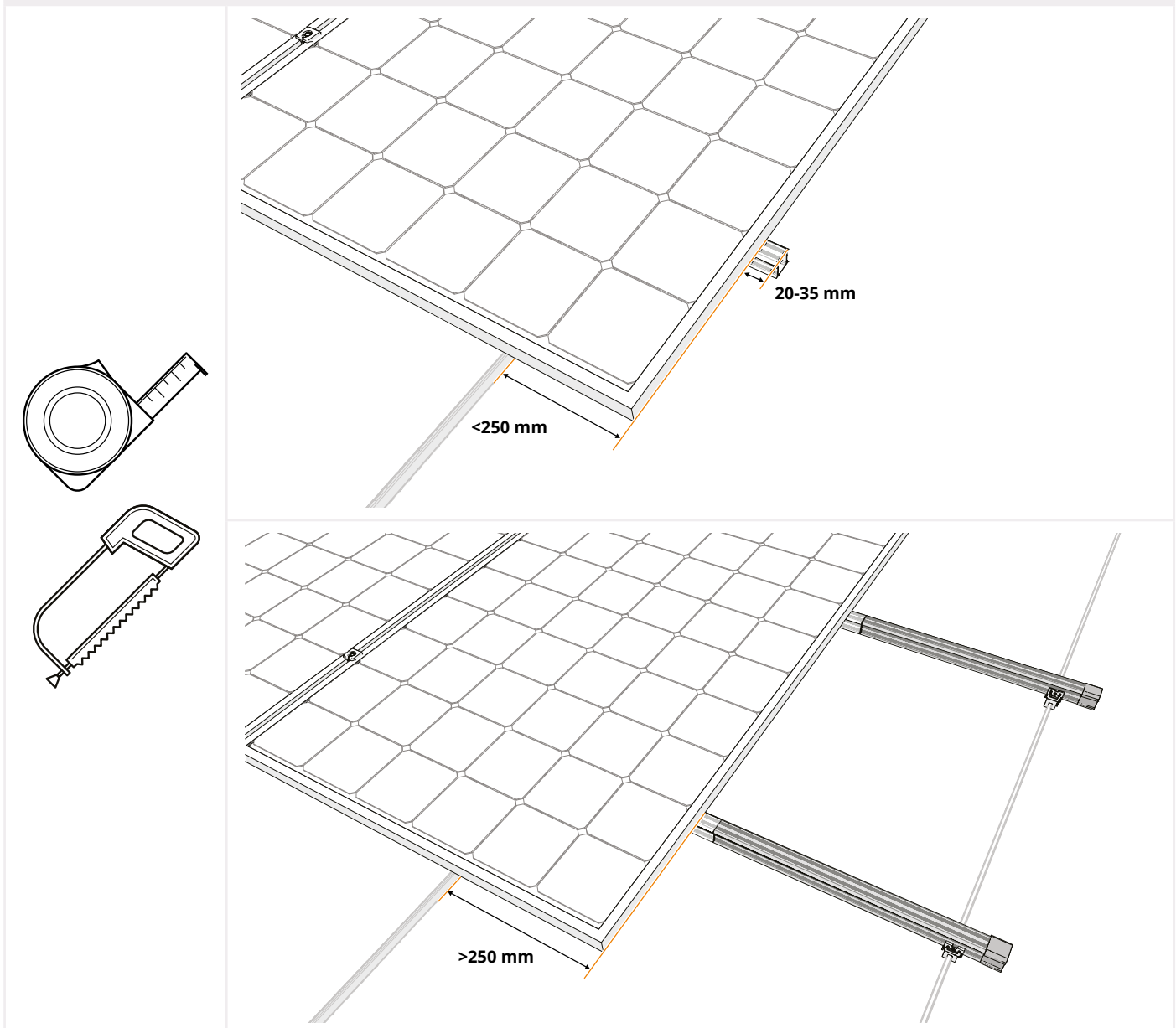

-  Optional: Repeat steps 6.1. Click the Auxiliary seton the panel and 6.2. Click the cables of the panel firmly into the cable clamp.
-  Repeat step 6.6. Place the panel on the rails
-  Repeat step 7.2. Slide the panel against the clamps

1 OPTIONAL: SAW THE MOUNTING RAILS TO SIZE



-  If the overhang is smaller than 250 mm, keep a minimum of 20 mm to a maximum of 35 mm rail length overhang for mounting the end cap (art. no.1008060(-B)).
-  If the outer panel edge is more than 250 mm outside the first/last seam, extend the mounting rail to 50 mm beyond the previous/next seam and provide a seam clamp here for attachment. The extra 50 mm facilitates sufficient length to accommodate the mounting rails of the end cap (art. no. 1008066(-B)). At the location of the end clamp, you must provide the end clamp support (art. no. 1008065(-B)).

2 CLICK THE UNIVERSAL MODULE CLAMP ON THE RAILS

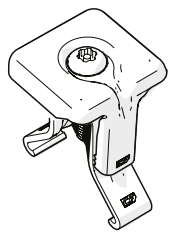

2x

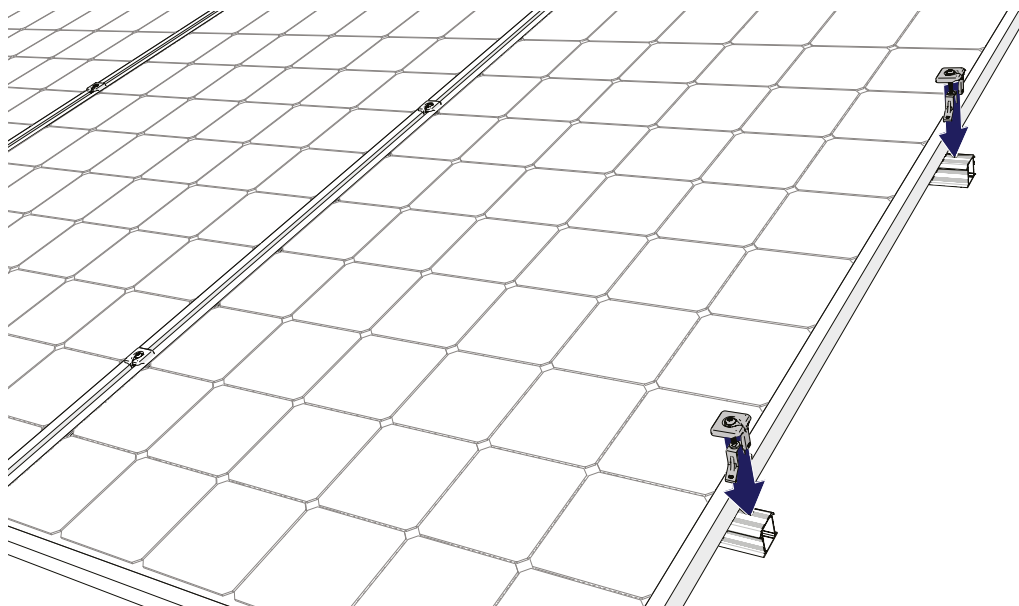

3 SLIDE THE END CAPS ONTO THE RAILS

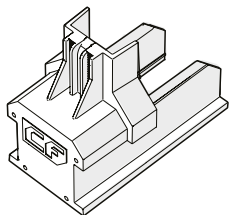

2x

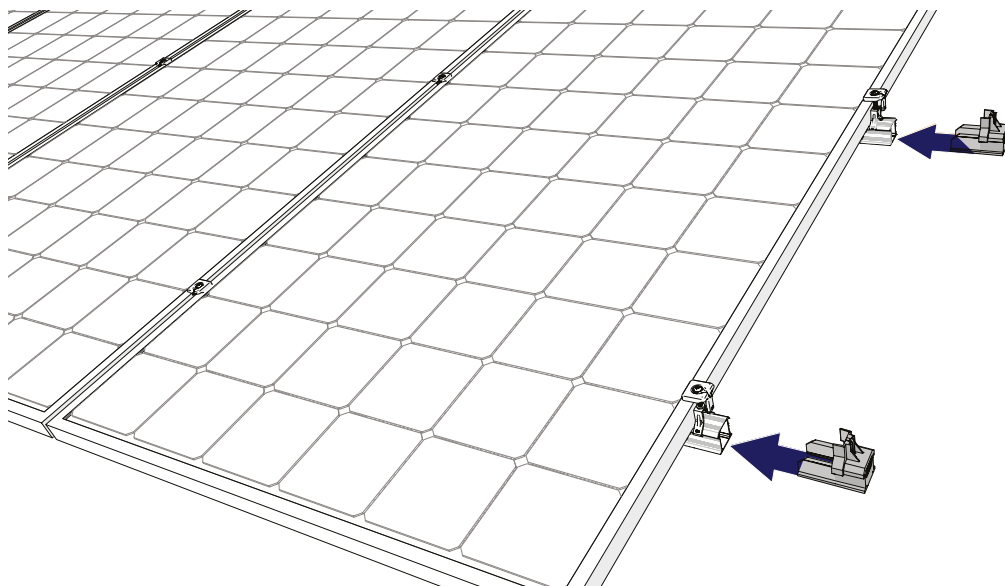

4 ROTATE THE UPPER PART OF THE MODULE CLAMP OVER THE END CAP

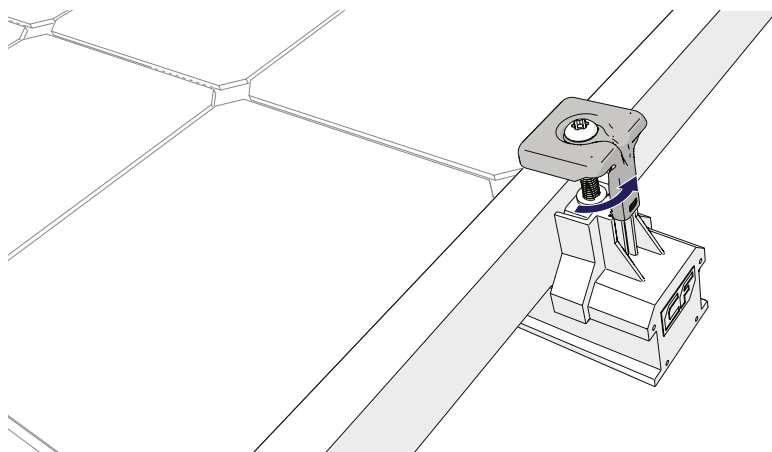

2x

5 SCREW THE CLAMPS ONTO THE PANEL

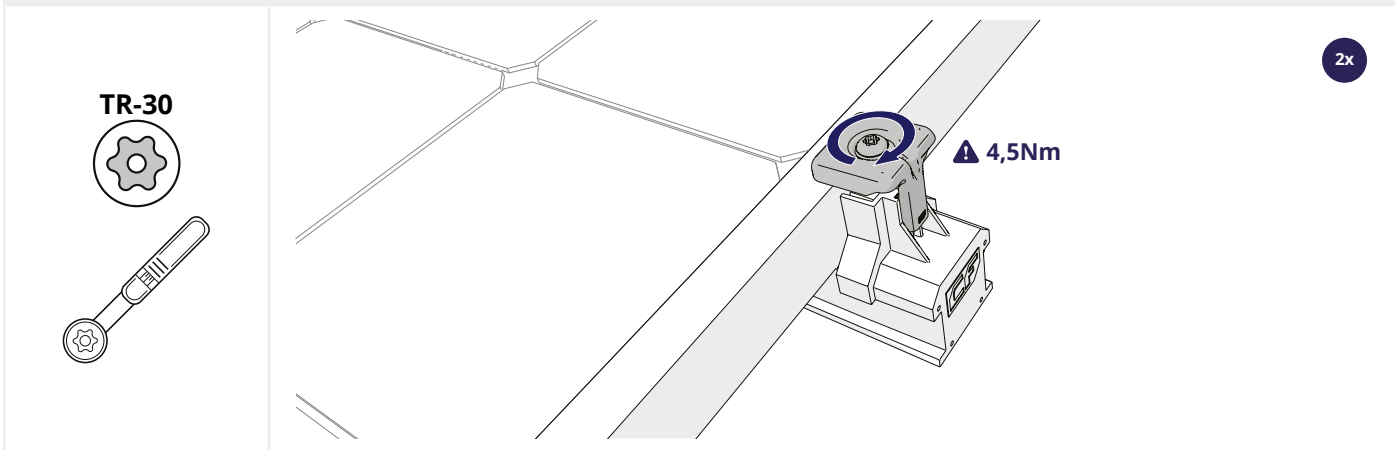

9 MOUNTING MULTIPLE ROWS

1 MOUNT EACH NEXT ROW AGAINST THE PREVIOUS ROW

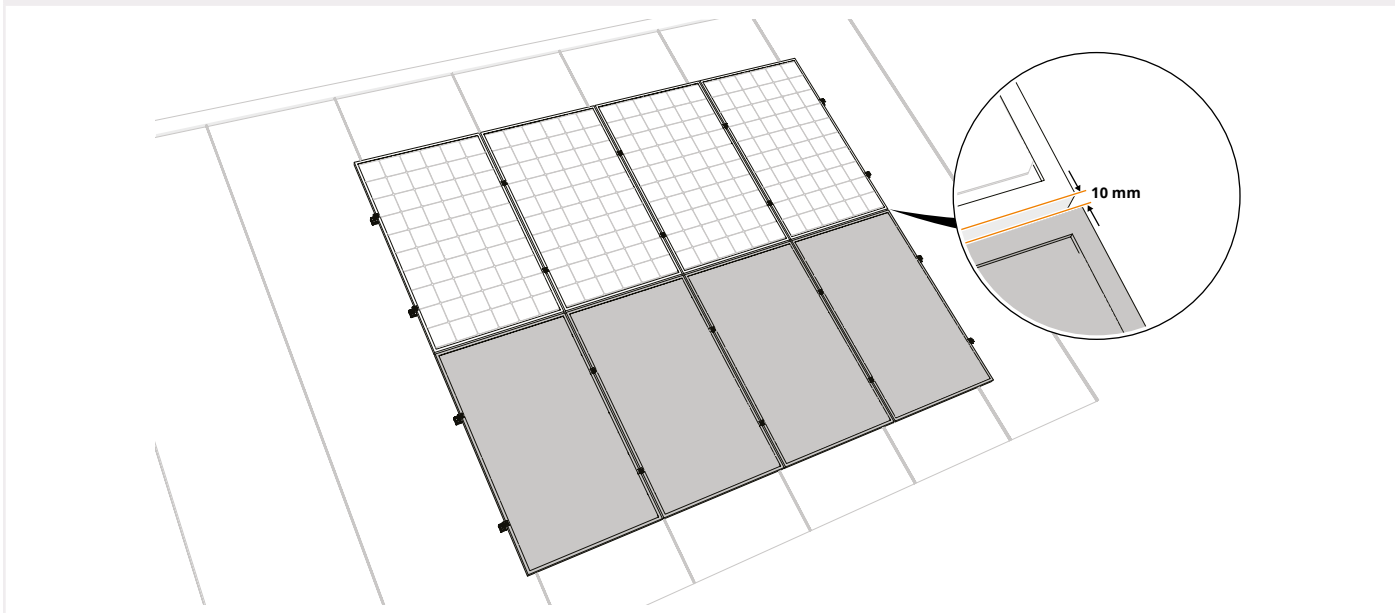

- i** Always keep a minimum of 10 mm between each row of panels in the case of horizontally oriented rails, or each panel column in the case of vertically oriented rails.
- i** Always follow the project plan from the calculator.

DISMANTLING AND DISPOSAL

GENERAL

Always follow local laws and regulations when dismantling the mounting system and disposing of it.



**BUILDING VALUE ⁺ FOR
SOLAR PROFESSIONALS**

Esdec

Londenstraat 16
7418 EE Deventer
The Netherlands

☎ +31 850 702 000

✉ info@esdec.com

www.esdec.com

210322