



INSTALLATION INSTRUCTIONS

PVSHELTER WALL FLOOR TYPE 150 HE
ART.NR: PVS200319-8-NA

INDEX



BLADZIJDE 3 - 7



PAGE 8 - 12



SEITE 13 - 17



PAGE 18 - 22



PÁGINA 23 - 27





GEREEDSCHAP

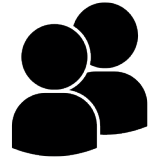

MATERIALEN

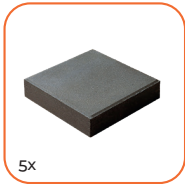

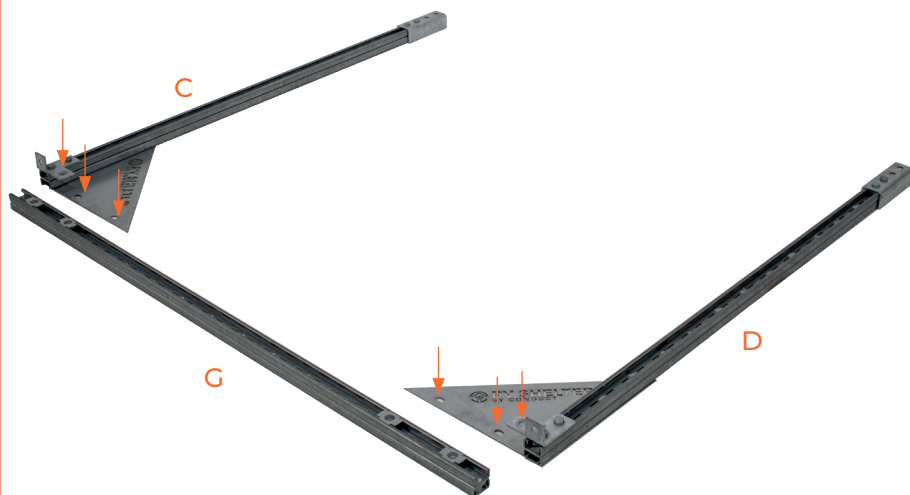
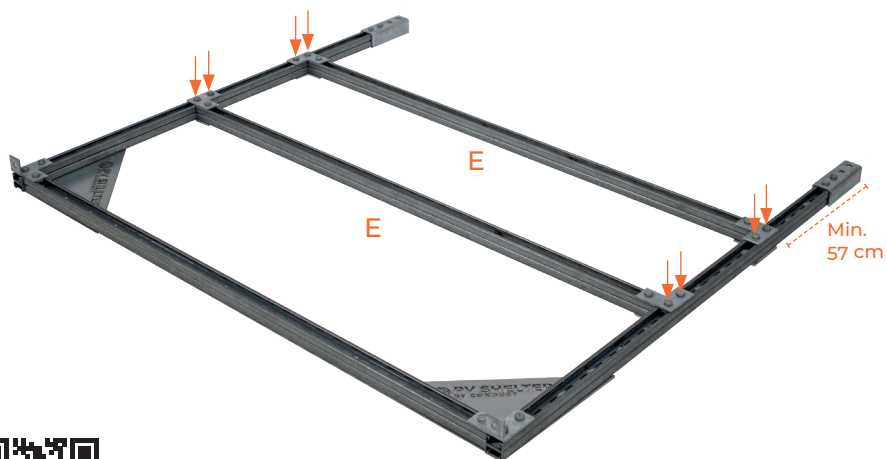
1**MONTEER PROFIEL G OP PROFIEL C EN D MET 6 BOUTEN (20MM)****2****PLAATS BEIDE E-PROFIELEN OP GEWENSTE AFSTAND EN MONTEER**

Scan voor de montagehandleiding van de gewenste omvormer

3 PLAATS BASISFRAME (A)

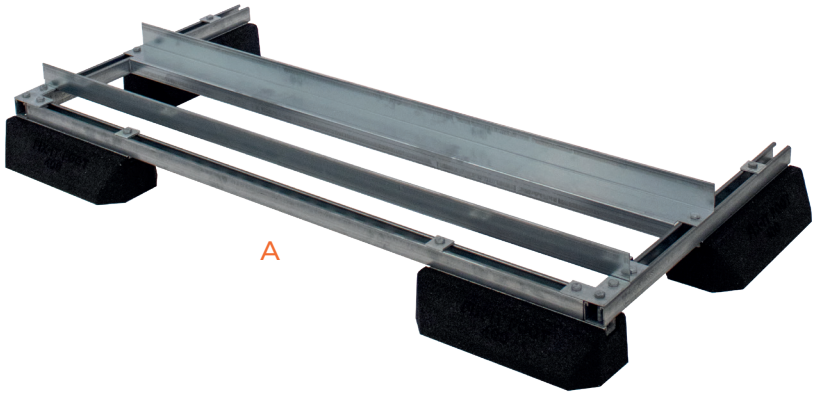

4 PLAATS OMVORMERFRAME OP BODEMFRAME



5 MONTEER 2 x PROFIEL F OP 45°



6 PLAATS DAK (I) OP OMVORMERFRAME



7

VERZWAAR MET BETONTEGELS



Let op: PVshelter Wall-Floor en PVshelter Wall moeten ten alle tijden tegen een muur/gevel worden geplaatst



TOOLS

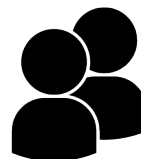
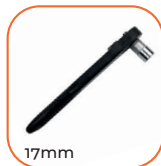

SUPPLIES

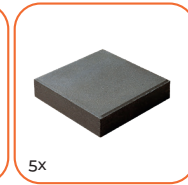
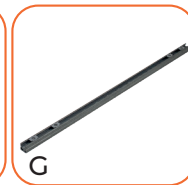
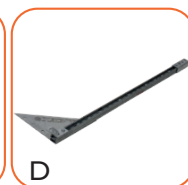

1

MOUNT PROFILE G ON PROFILE C AND D WITH 6 BOLTS (20MM)

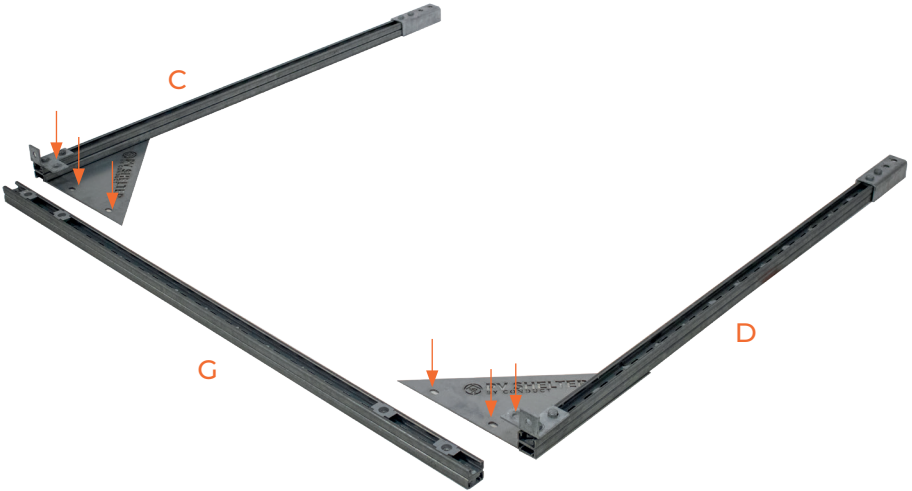

2

POSITION BOTH E-PROFILES AT THE DESIRED DISTANCE AND ASSEMBLE



Scan for the installation manual of the desired inverter

3 POSITION BASE FRAME (A)

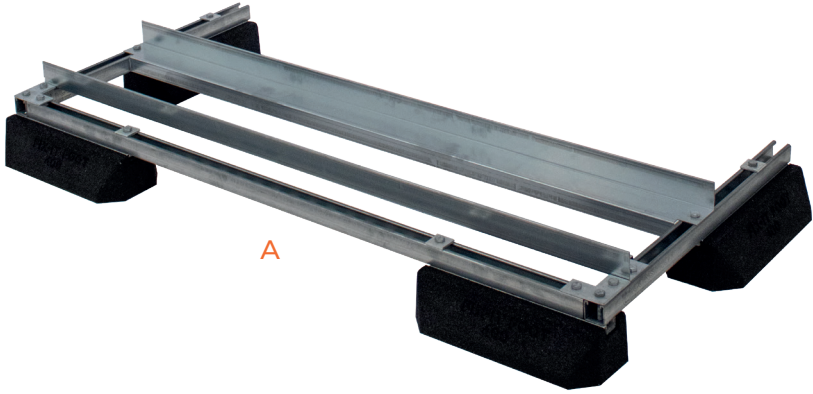

4 POSITION INVERTER FRAME ONTO BASE FRAME



5 MOUNT 2x PROFILE F AT A 45° ANGLE



6 POSITION ROOF (I) ONTO INVERTER FRAME



7

WEIGH DOWN WITH CONCRETE TILES



Note: PVshelter Wall-Floor and PVshelter Wall must always be installed against a wall/façade



WERKZEUGE



KOMPONENTEN

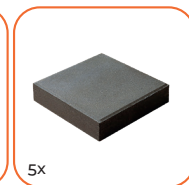
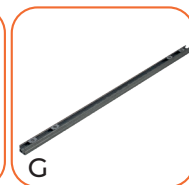
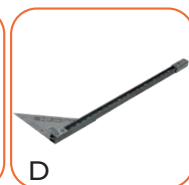

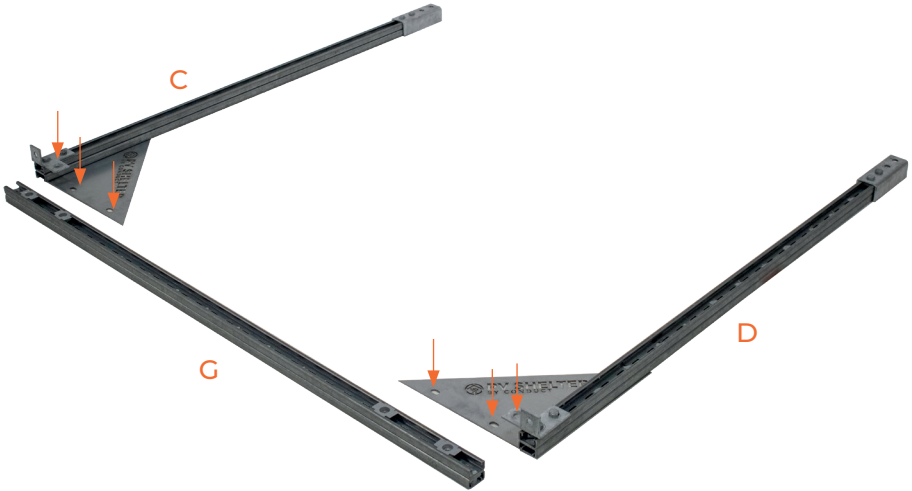
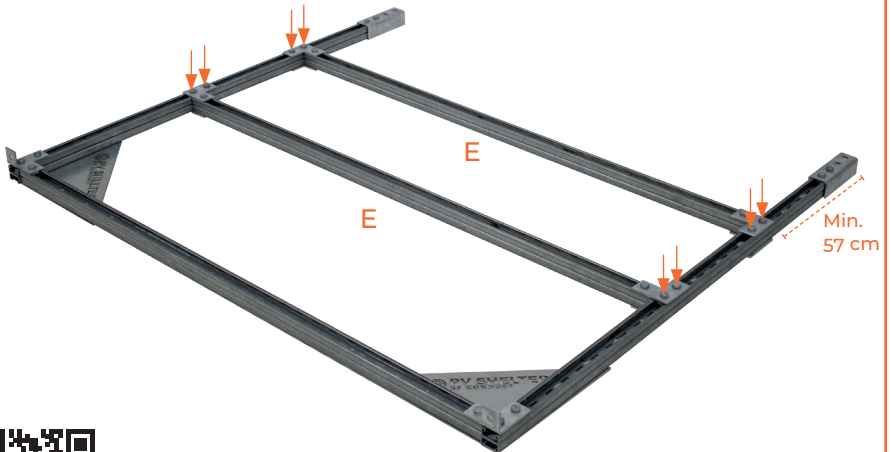
1**PROFIL G AUF PROFIL C UND D MIT 6 SCHRAUBEN (20MM)****2****BRINGEN SIE BEIDE E-PROFILE IN DEN GEWÜNSCHTEN ABSTAND UND MONTIEREN SIE**

QR-Code für die Montageanleitung des gewünschten Wechselrichters scannen

3 POSITIONIEREN SIE DEN BASISRAHMEN (A)

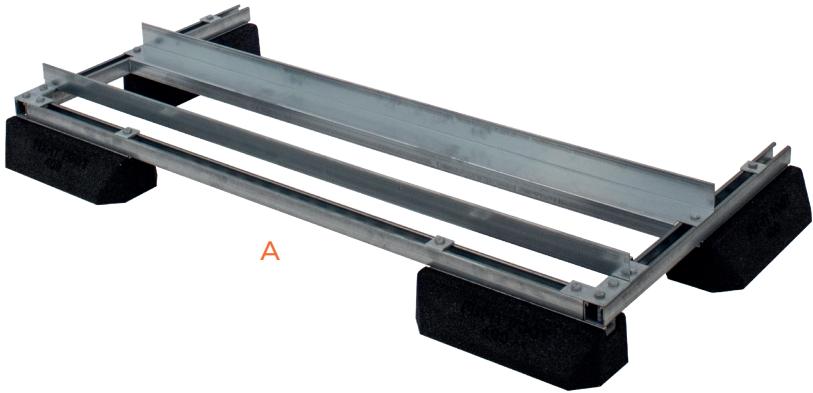

4 POSITIONIEREN SIE DEN WECHSELRICHTERMONTAGERAHMEN AUF DEM BASISRAHMEN



5 MONTIERE 2X PROFIL F IN EINEM 45°-WINKEL



6 POSITIONIERE DAS DACH (I) AUF WECHSELRICHTERMONTAGERAHMEN



7

MIT BETONPLATTEN BESCHWEREN



Hinweis: PVshelter Wall-Floor und PVshelter Wall müssen stets an einer Wand/Fassade montiert werden



OUTILS

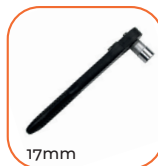

MATÉRIEL

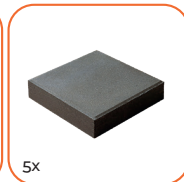

1 MONTER LE PROFIL G SUR LES PROFILS C ET D AVEC 6 BOULONS (20MM)

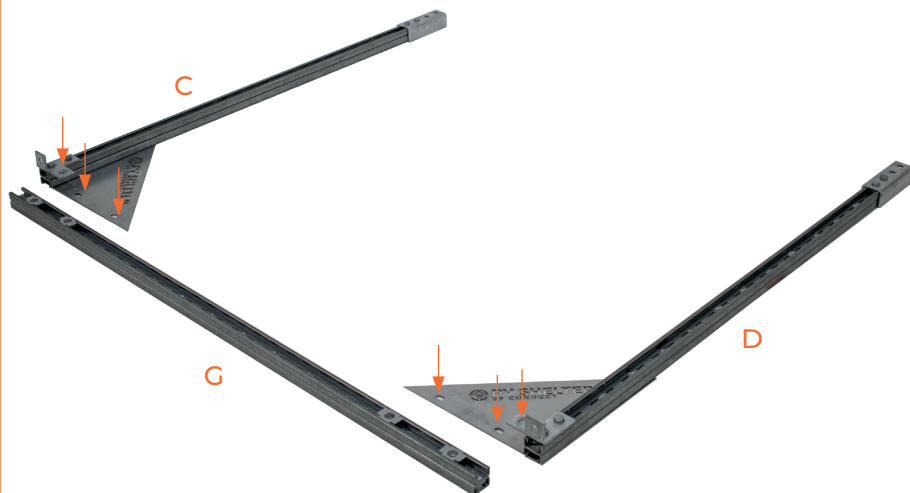

2 PLACEZ LES DEUX PROFILS EN E À LA DISTANCE SOUHAITÉE ET MONTEZ

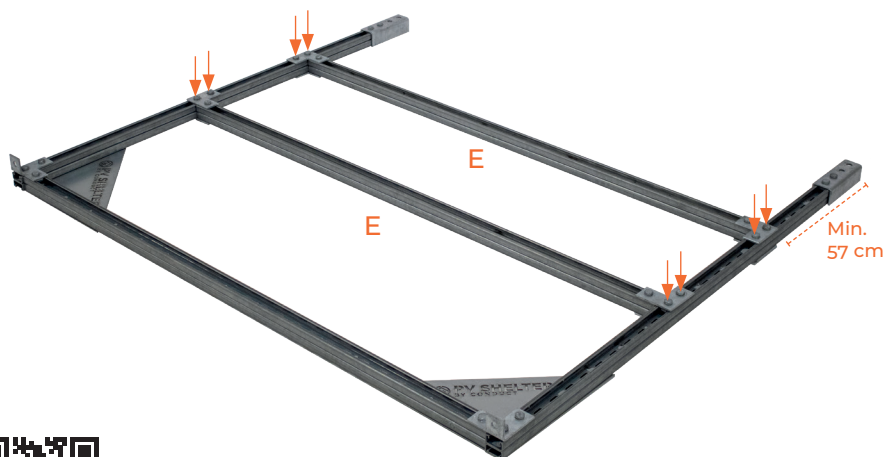

Scanner le code QR pour le manuel d'installation de l'onduleur souhaité

3 POSITIONNE LE CADRE DE BASE (A)

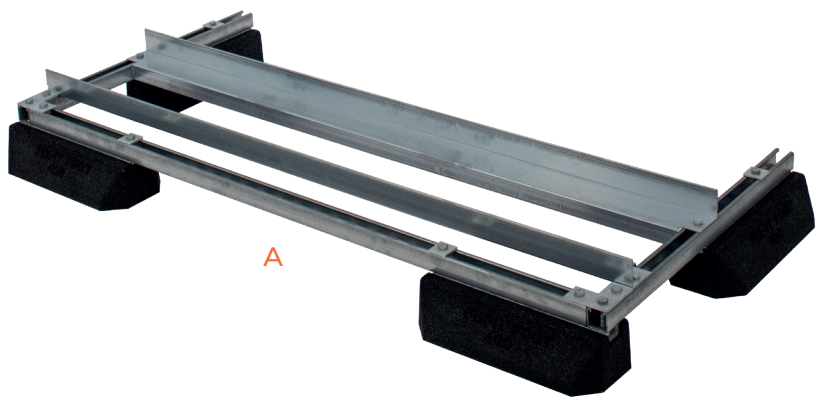

4 POSITIONNE LE CADRE DE L'ONDULEUR SUR LE CADRE DE BASE



5 MONTE 2x PROFIL F À UN ANGLE DE 45°



6 POSITIONNE LE TOIT (I) SUR LE CADRE DE L'ONDULEUR



7

LESTE AVEC DES DALLES EN BÉTON



Remarque : PVshelter Wall-Floor et PVshelter Wall doivent toujours être installés contre un mur ou une façade



HERRAMIENTAS



SUMINISTROS

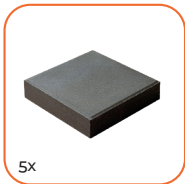

1 MONTAR EL PERFIL G SOBRE LOS PERFILES C Y D CON 6 PERNOS (20MM)

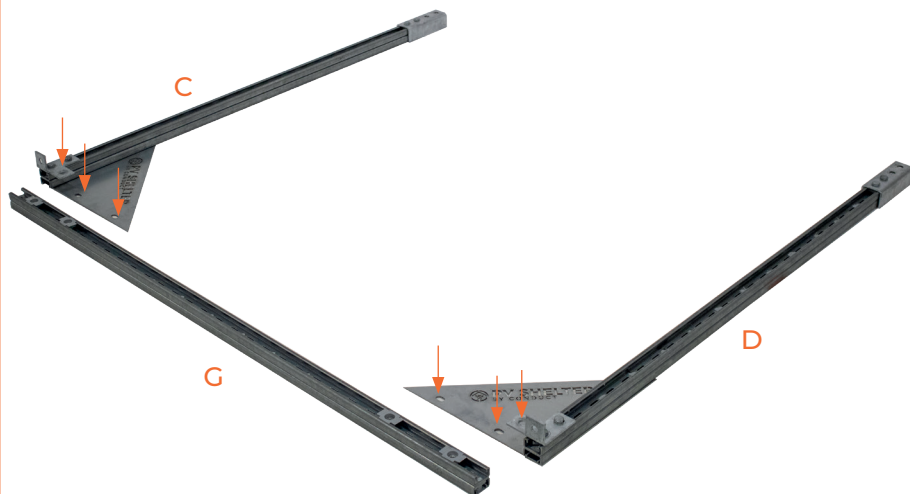

2 COLOQUE AMBOS PERFILES EN E A LA DISTANCIA DESEADA Y MONTE

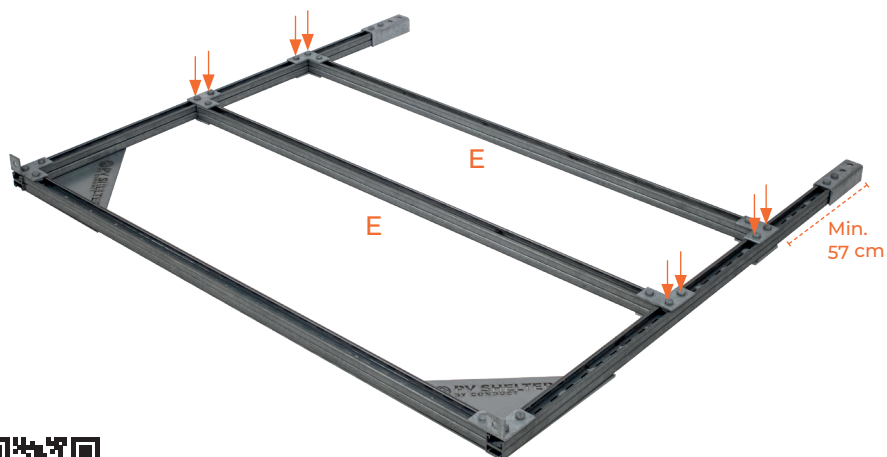

Escanea para ver el manual de instalación del inversor deseado

3 COLOQUE EL BASTIDOR BASE (A)

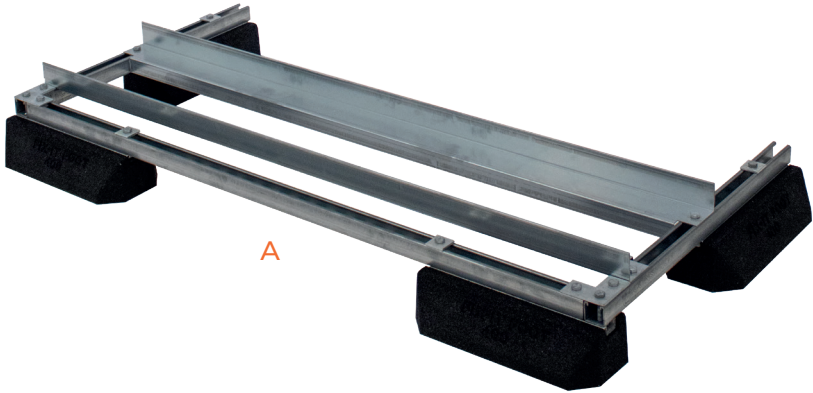

4 COLOQUE EL BASTIDOR DEL INVERSOR SOBRE EL BASTIDOR BASE



5 MONTE 2X PERFIL F EN UN ÁNGULO DE 45°



6 COLOCA EL TECHO (I) EN EL MARCO DEL INVERSOR



7

LASTRE CON BALDOSAS DE HORMIGÓN



Nota: PVshelter Wall-Floor y PVshelter Wall deben instalarse siempre contra una pared o fachada

Plaatsingsrichtlijnen

- Stormbestendigheid: Voor optimale windweerstand, plaats de PVshelter met de zijkant naar het zuidwesten.
- Ballast: Gebruik alle meegeleverde betontegels voor een stabiele montage.
- Vereffening: Zorg voor correcte potentiaalvereffening met een aardrail en vereffeningkits.
- Locatie: Wall-Floor en Wall-versies moeten altijd tegen een muur of gevel worden geplaatst.

Placement Guidelines

- Storm resistance: For optimal wind resistance, place the PVshelter with the side facing southwest.
- Ballast: Use all supplied concrete tiles for a stable installation.
- Potential equalization: Ensure correct equipotential bonding with a ground rail and bonding kits.
- Location: Wall-Floor and Wall versions must always be placed against a wall or façade.

Platzierungsrichtlinien

- Sturmfestigkeit: Für optimalen Windwiderstand den PVshelter mit der Seite nach Südwesten ausrichten.
- Ballast: Verwenden Sie alle mitgelieferten Betonplatten für eine stabile Installation.
- Potentialausgleich: Sorgen Sie für eine korrekte Potentialausgleichung mit einer Erdungsschiene und Ausgleichssätzen.
- Standort: Wall-Floor- und Wall-Versionen müssen immer an einer Wand oder Fassade montiert werden.

Directives d'installation

- Résistance aux tempêtes: Pour une résistance optimale au vent, placez le PVshelter avec le côté face au sud-ouest.
- Ballast: Utilisez toutes les dalles en béton fournies pour une installation stable.
- Équipotentialité: Assurez une liaison équipotentielle correcte avec un rail de mise à la terre et des kits de mise à la terre.
- Emplacement: Les versions Wall-Floor et Wall doivent toujours être placées contre un mur ou une façade.

Directrices de instalación

- Resistencia a tormentas: Para una resistencia óptima al viento, coloque el PVshelter con el lado orientado al suroeste.
- Lastre: Utilice todas las losas de hormigón suministradas para una instalación estable.
- Compensación de potencial: Asegure una correcta equipotencialidad con un carril de tierra y kits de conexión.
- Ubicación: Las versiones Wall-Floor y Wall deben colocarse siempre contra una pared o fachada.

Conduct Technical Solutions BV
Fennaweg 24, 2991 ZA Barendrecht
The Netherlands

+31 (0) 180-531120 | info@conduct.nl | conduct.nl