



INSTALLATION INSTRUCTIONS

PV SHELTER BACK2BACK TYPE 300 HE
ART.NR: PVS200319-7-NA

INDEX



BLADZIJDE 3 - 7



PAGE 8 - 12



SEITE 13 - 17



PAGE 18 - 22



PÁGINA 23 - 27





GEREEDSCHAP



MATERIALEN

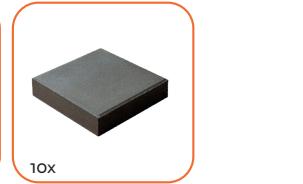
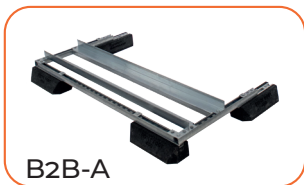

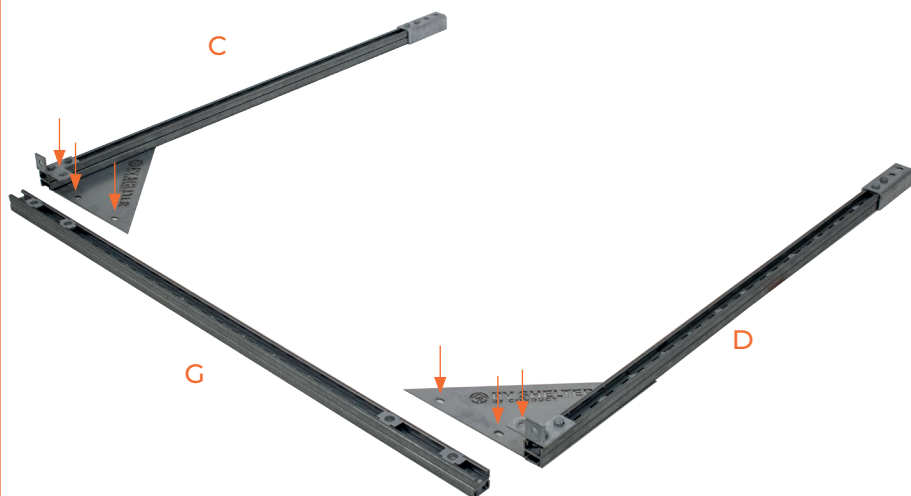
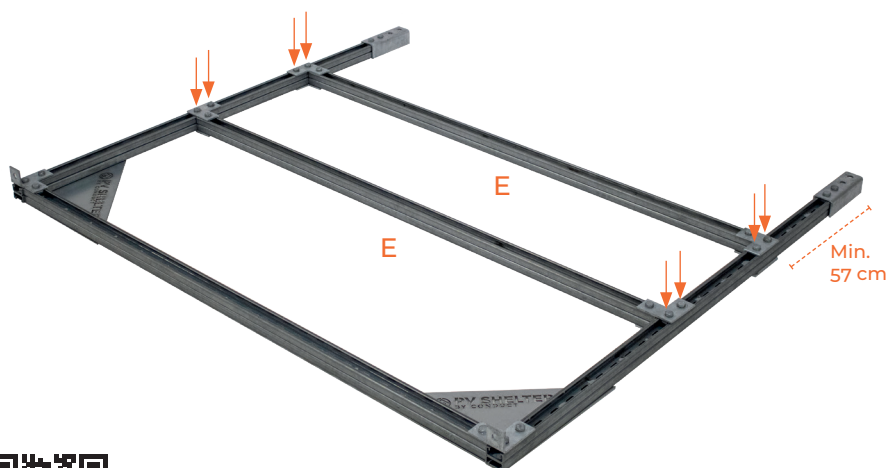
1**MONTEER PROFIEL G OP PROFIEL C EN D MET 6 BOUTEN (20MM)****2****BEVESTIG BEIDE E-PROFIELEN OP GEWENSTE AFSTAND**

Scan voor de montagehandleiding van de gewenste omvormer

3 PLAATS BASISFRAME (B2B-A)



4 PLAATS BASISFRAME B2B-A EN BEVESTIG AAN B2B-A MET 4 BOUTEN (25MM)

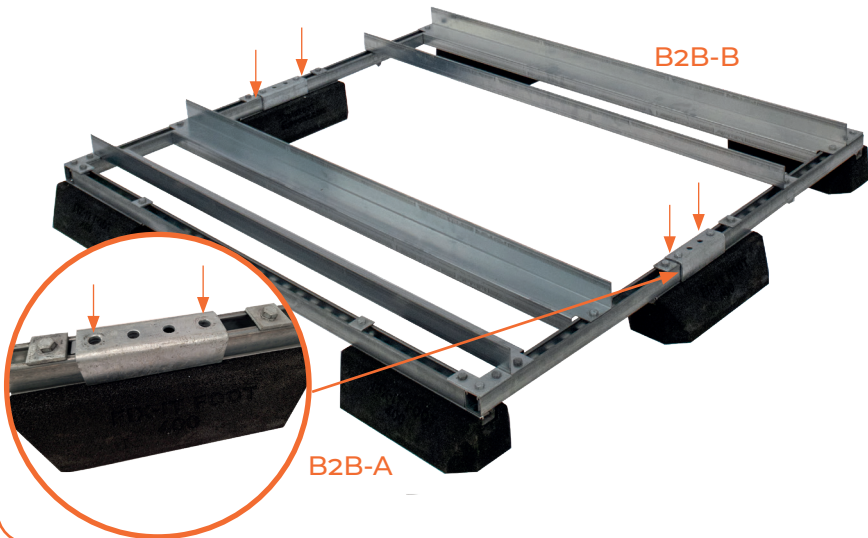

5 PLAATS OMVORMERFRAME OP BASISFRAME



6 MONTEER 4 x PROFIEL F ONDER EEN HOEK VAN 45°



7 PLAATS DAK (H) OP OMVORMERFRAME



8 VERZWAAR MET BETONTEGELS





TOOLS

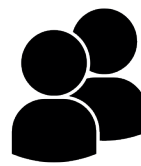
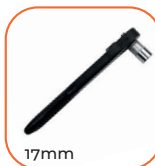

SUPPLIES

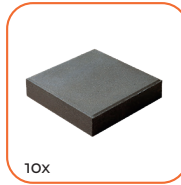
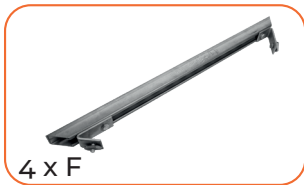
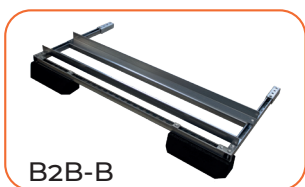
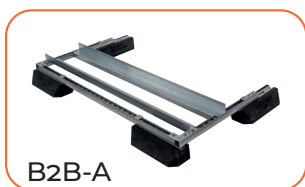

1

MOUNT PROFILE G ON PROFILE C AND D WITH 6 BOLTS (20 MM)

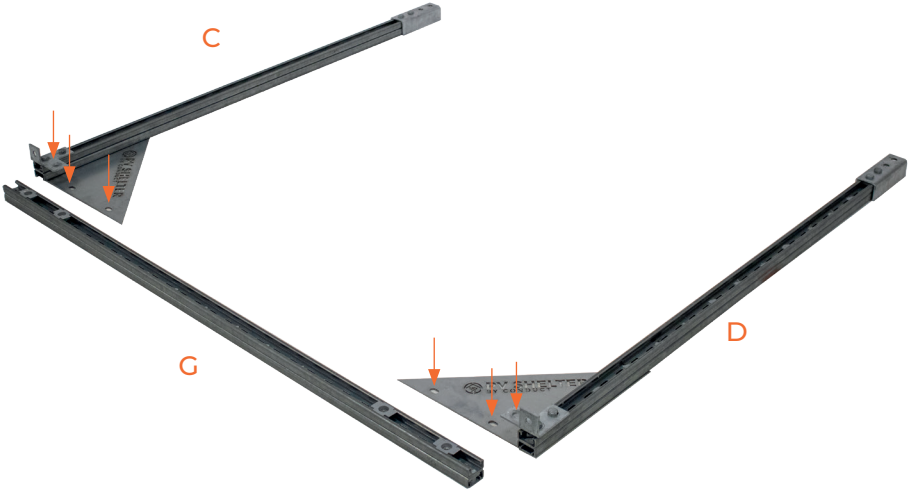

2

MOUNT BOTH E-PROFILES AT THE DESIRED DISTANCE

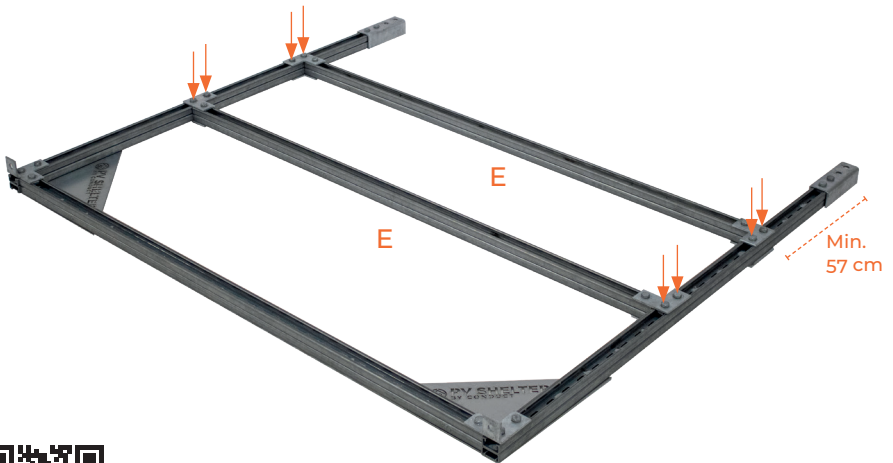

Scan for the installation manual of the desired inverter

3 POSITION BASE FRAME (B2B-A)



4 PLACE BASE FRAME B2B-B AND SECURE IT TO B2B-A USING 4 BOLTS (25 MM)

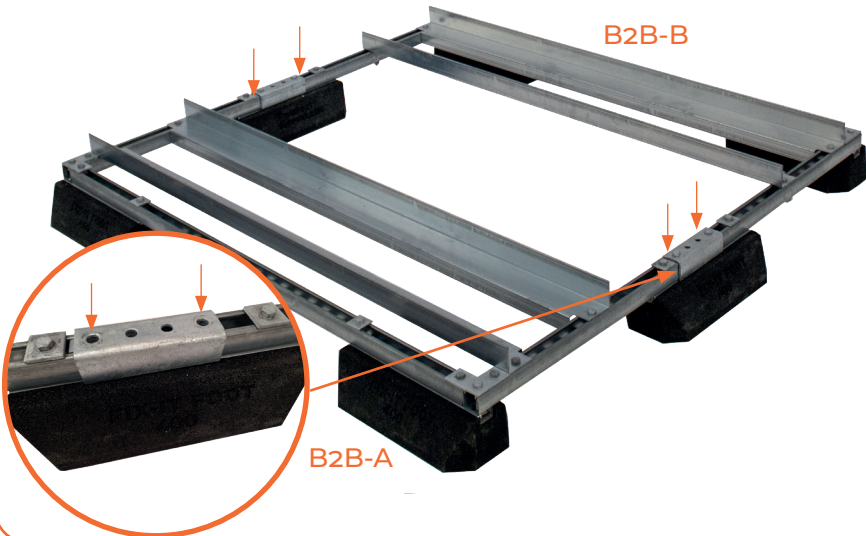

5 POSITION INVERTER FRAME ONTO BASE FRAME



6 MOUNT 4 x PROFILE F AT 45° ANGLE



7

POSITION ROOF (H) ONTO INVERTER FRAME



8

WEIGH DOWN WITH CONCRETE TILES





WERKZEUGE



KOMPONENTEN

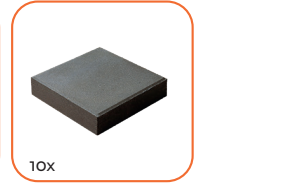
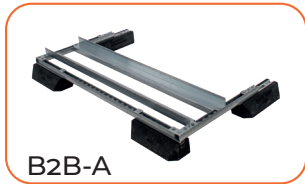

1

PROFIL G AUF PROFIL C UND D MIT 6 SCHRAUBEN (20 MM) MONTIEREN

**2**

BEFESTIGE BEIDE E-PROFILE IM GEWÜNSCHTEN ABSTAND

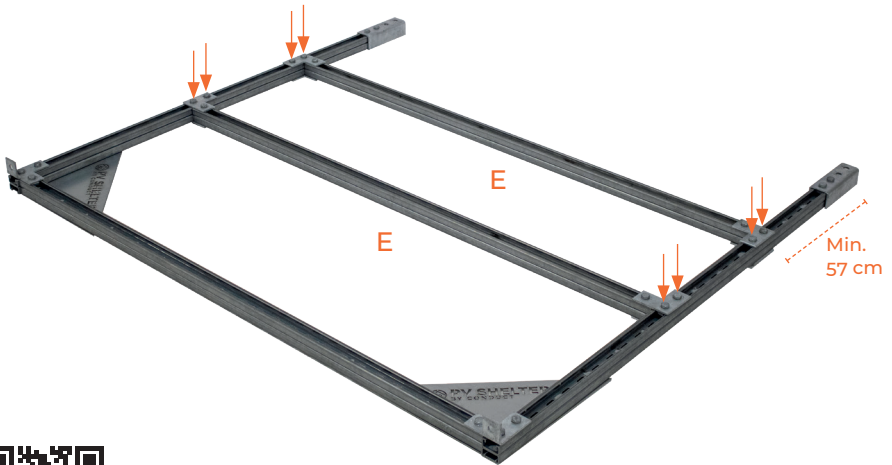

Scannen Sie für das Installationshandbuch des gewünschten Wechselrichters

3 POSITIONIEREN SIE DEN BASISRAHMEN (B2B-A)



4 SETZEN SIE DAS BASISGESTELL B2B-B UND BEFESTIGEN SIE ES MIT 4 BOLZEN (25 MM) AN B2B-A

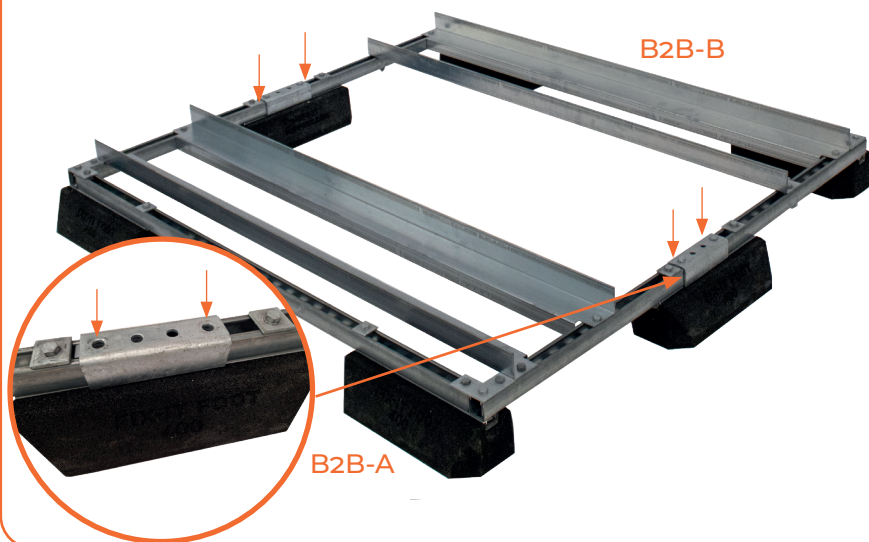

5 POSITIONIEREN SIE DEN WECHSELRICHTERMONTAGERAHMEN AUF DEM BASISRAHMEN



6 MONTIEREN SIE 4 x PROFIL F IM 45°-WINKEL

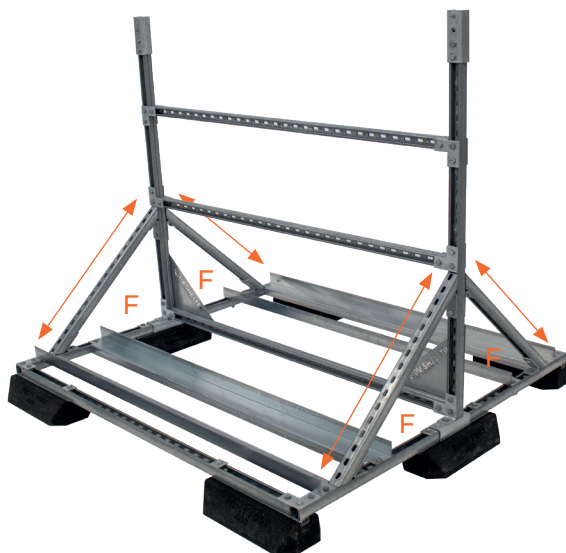

7

POSITIONIEREN SIE DAS DACH (H) AUF DEN WECHSELRICHTERRAHMEN



8

MIT BETONPLATTEN BESCHWEREN





OUTILS

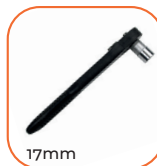

MATÉRIEL

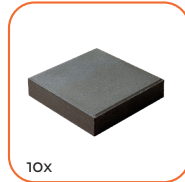

1 MONTER LE PROFIL G SUR LES PROFILS C ET D AVEC 6 BOULONS (20 MM)

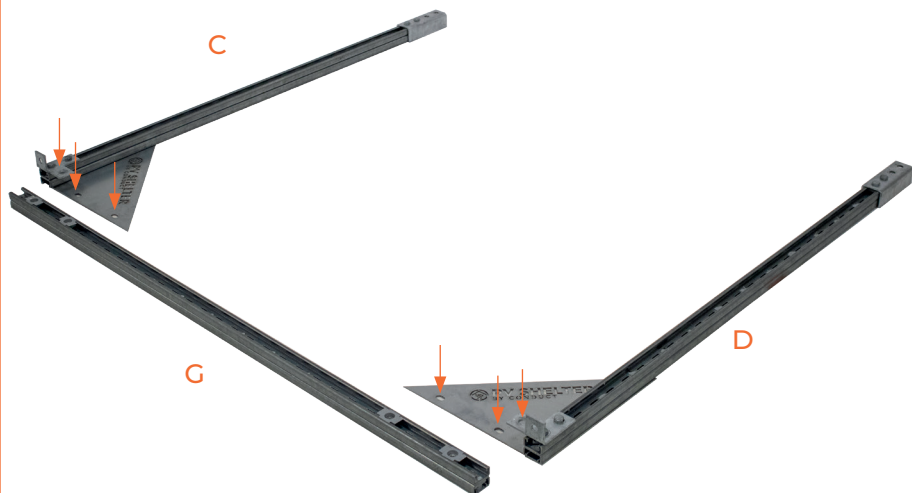

2 FIXEZ LES DEUX PROFILS EN E À LA DISTANCE SOUHAITÉE

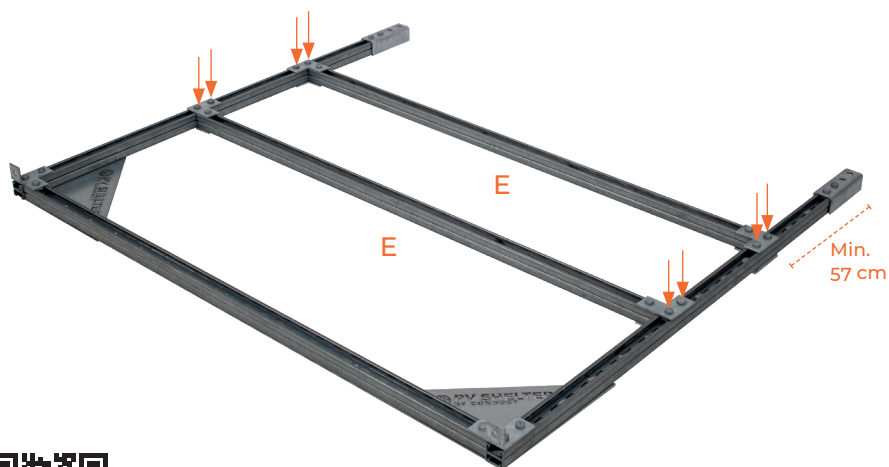

Scanne le manuel d'installation de l'onduleur souhaité

3 POSITIONNE LE CADRE DE BASE (B2B-A)



4 PLACE LE CHÂSSIS DE BASE B2B-B ET FIXE-LE À B2B-A AVEC 4 BOULONS (25 MM)

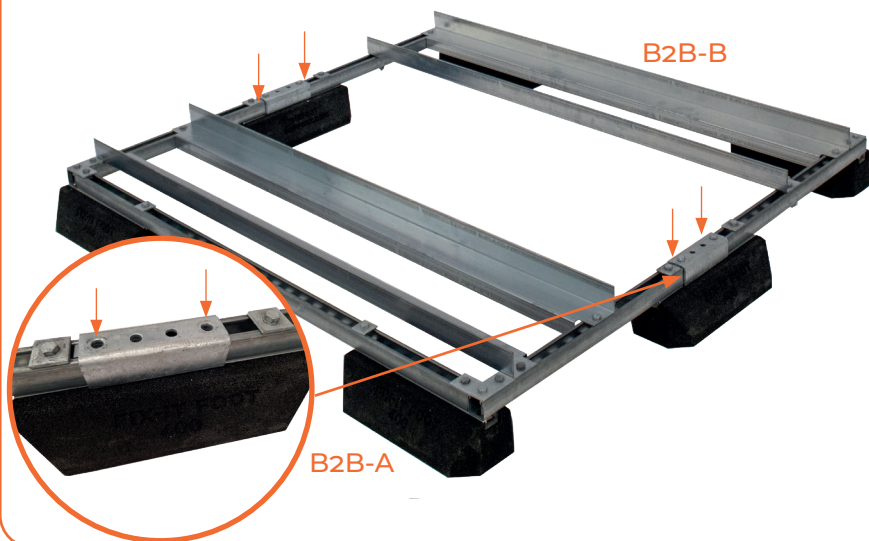

5 POSITIONNE LE CADRE DE MONTAGE DE L'ONDULEUR SUR LE CADRE DE BASE

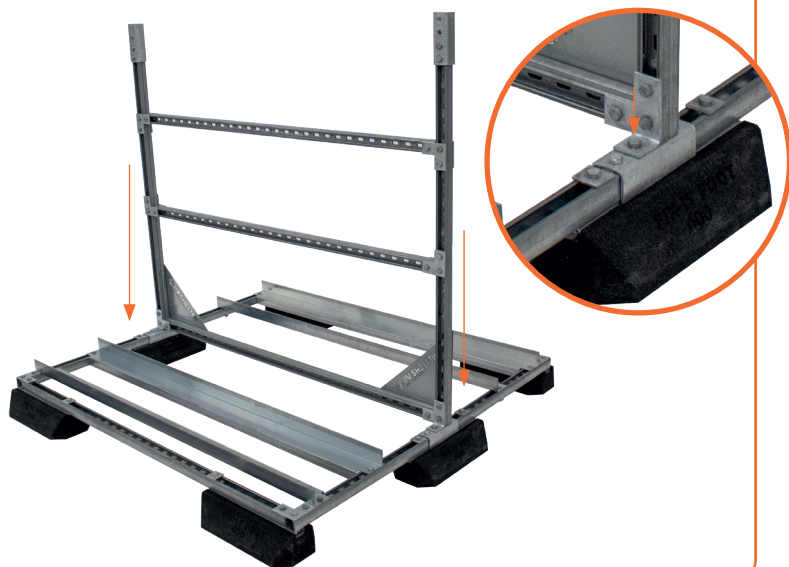

6 MONTE 4 x PROFILS F À UN ANGLE DE 45°



7 POSITIONNER LE TOIT (H) SUR LE CADRE DE L'ONDULEUR



8 LESTER AVEC DES DALLES EN BÉTON





HERRAMIENTAS

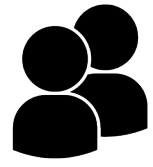

SUMINISTROS

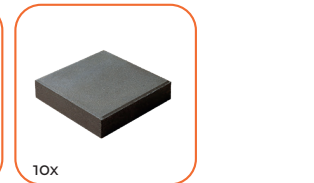
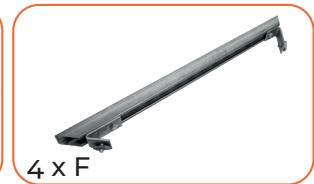
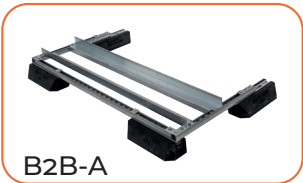

1 MONTAR EL PERFIL G SOBRE LOS PERFILES C Y D CON 6 PERNOS (20 MM)

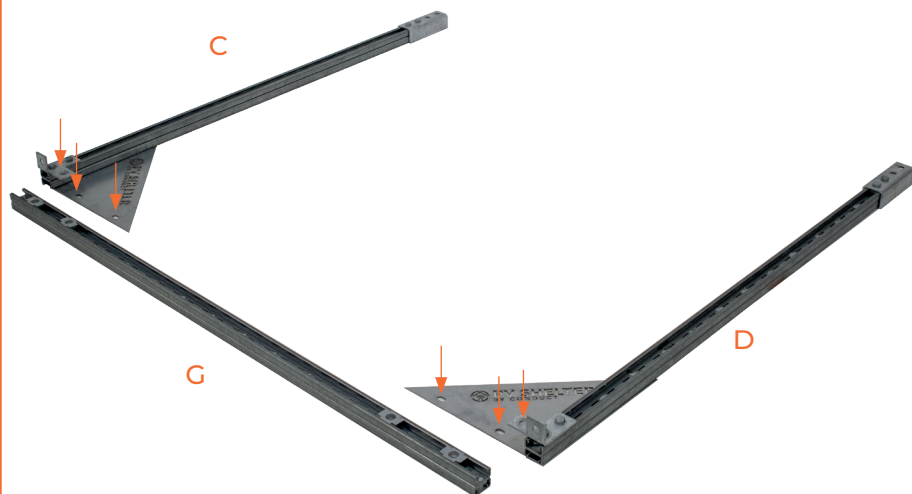

2 FIJA AMBOS PERFILES EN E A LA DISTANCIA DESEADA

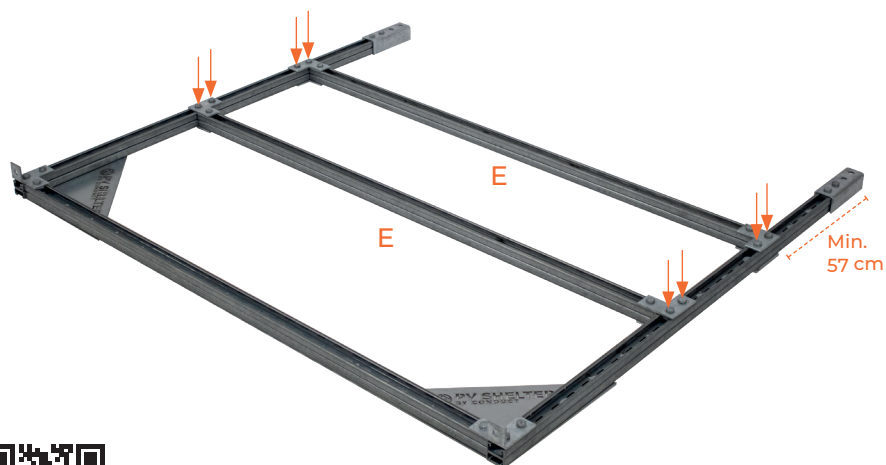

Escanee para obtener el manual de montaje del inversor deseado

3 COLOQUE EL BASTIDOR BASE (B2B-A)



4 COLOQUE EL BASTIDOR BASE B2B-B Y FÚELO A B2B-A CON 4 PERNOS (25 MM)

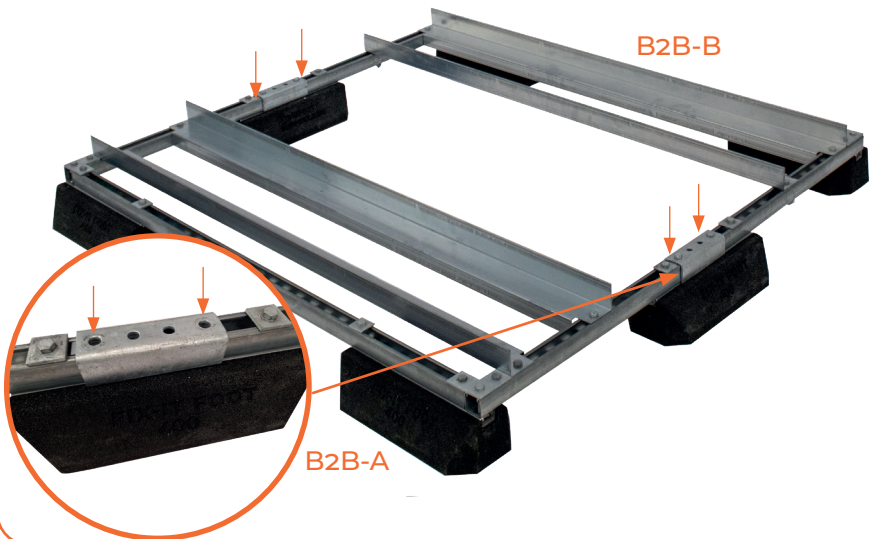

5 COLOQUE EL MARCO DEL INVERSOR SOBRE EL BASTIDOR BASE



6 MONTE 4x PERFILES F EN UN ÁNGULO DE 45°



7 COLOQUE EL TECHO (H) SOBRE EL MARCO DEL INVERSOR



8 LASTRE CON LOSAS DE HORMIGÓN



Plaatsingsrichtlijnen

- Stormbestendigheid: Voor optimale windweerstand, plaats de PVshelter met de zijkant naar het zuidwesten.
- Ballast: Gebruik alle meegeleverde betontegels voor een stabiele montage.
- Vereffening: Zorg voor correcte potentiaalvereffening met een aardrail en vereffeningskits.
- Locatie: Wall-Floor en Wall-versies moeten altijd tegen een muur of gevel worden geplaatst.

Placement Guidelines

- Storm resistance: For optimal wind resistance, place the PVshelter with the side facing southwest.
- Ballast: Use all supplied concrete tiles for a stable installation.
- Potential equalization: Ensure correct equipotential bonding with a ground rail and bonding kits.
- Location: Wall-Floor and Wall versions must always be placed against a wall or façade.

Platzierungsrichtlinien

- Sturmfestigkeit: Für optimalen Windwiderstand den PVshelter mit der Seite nach Südwesten ausrichten.
 - Ballast: Verwenden Sie alle mitgelieferten Betonplatten für eine stabile Installation.
 - Potentialausgleich: Sorgen Sie für eine korrekte Potentialausgleichung mit einer Erdungsschiene und Ausgleichssätzen.
- Standort: Wall-Floor- und Wall-Versionen müssen immer an einer Wand oder Fassade montiert werden.

Directives d'installation

- Résistance aux tempêtes: Pour une résistance optimale au vent, placez le PVshelter avec le côté face au sud-ouest.
- Ballast: Utilisez toutes les dalles en béton fournies pour une installation stable.
- Équipotentialité: Assurez une liaison équipotentielle correctae avec un rail de mise à la terre et des kits de mise à la terre.
- Emplacement: Les versions Wall-Floor et Wall doivent toujours être placées contre un mur ou une façade.

Directrices de instalación

- Resistencia a tormentas: Para una resistencia óptima al viento, coloque el PVshelter con el lado orientado al suroeste.
- Lastre: Utilice todas las losas de hormigón suministradas para una instalación estable.
- Compensación de potencial: Asegure una correcta equipotencialidad con un carril de tierra y kits de conexión.
- Ubicación: Las versiones Wall-Floor y Wall deben colocarse siempre contra una pared o fachada.

Conduct Technical Solutions BV

Fennaweg 24, 2991 ZA Barendrecht
The Netherlands

+31 (0) 180-531120 | info@conduct.nl | conduct.nl