

Operating Instructions

Fronius Wattpilot Flex

Home 11 C6

Home 22 C6

Pro 11 C6E

Pro 22 C6E

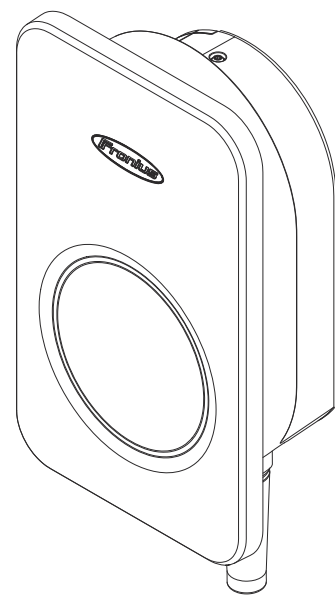

EN-US | Operating instructions



Table of contents

General information	5
Safety information.....	7
Explanation of warnings and safety instructions.....	7
Safety instructions and important information.....	7
Electromagnetic fields.....	8
EMC measures.....	9
General.....	10
Information on the device.....	10
Accessories and spare parts.....	10
Suitable inverters.....	10
Suitable generators from third-party manufacturers.....	11
Webinars and how-to videos.....	11
Target group.....	11
Data security.....	11
Updates.....	12
Copyright.....	12
Fronius Wattpilot Flex.....	13
Intended use.....	13
Foreseeable misuse.....	13
Scope of supply.....	14
Data communication.....	14
Keys and symbols.....	15
Product overview.....	15
Card reader.....	15
Operating mode buttons.....	15
LED status indicators.....	16
kW display.....	20
ID chip.....	21
Reset card.....	21
Functions.....	22
Overview.....	22
Phase changeover.....	22
Phase unbalanced load.....	22
PV surplus.....	22
Flexible electricity tariff.....	25
.....	26
Different charging modes.....	27
Standard Mode.....	27
Eco Mode.....	27
Next Trip Mode.....	28
Dynamic load balancing.....	31
General.....	31
Functional principle.....	31
Priority.....	32
Installation and Startup	35
Installation location and position.....	37
Choice of location.....	37
Installation position.....	37
Support foot.....	38
Installation.....	39
Safety.....	39
Mounting the Wattpilot on the wall.....	40
Fitting the charging plug holder.....	42
Installing the grid connection.....	43
Closing the device.....	46

Commissioning.....	48
Starting the charging process.....	48
Stopping charging.....	48
Backup power mode.....	48
Data communication with inverter.....	48
Commissioning with app.....	49
Download.....	49
Launching the app.....	49
Setting up the WLAN.....	50
Adding a Wattpilot.....	50
Fronius Solar.wattpilot app	51
Charging.....	53
Homepage.....	53
Energy per user.....	54
Settings.....	55
Next Trip Mode.....	55
Current level.....	55
Cost optimization.....	55
Charging timer.....	57
Load balancing.....	58
Name.....	58
Brightness.....	58
Time zone.....	58
Access management.....	59
Grounding test.....	59
ID chips.....	59
Password.....	60
Grid settings.....	60
Digital input.....	61
Internet.....	62
Connection.....	62
OCPP.....	62
Restart.....	63
Firmware update.....	63
Appendix	65
General.....	67
Residual current detection.....	67
Safety functions.....	67
Technical data.....	68
Wattpilot Flex Home 11 C6.....	68
Wattpilot Flex Home 22 C6.....	69
Wattpilot Flex Pro 11 C6E.....	70
Wattpilot Flex Pro 22 C6E.....	72
Status codes and remedy.....	74
Status codes.....	74
Terms and conditions of warranty and disposal.....	76
Fronius manufacturer's warranty.....	76
Disposal.....	76

General information

Safety information

Explanation of warnings and safety instructions

The warnings and safety instructions in these instructions are intended to protect people from possible injury and the product from damage.

DANGER!

Indicates an immediately dangerous situation

Serious injury or death will result if appropriate precautions are not taken.

- ▶ Action step to escape the situation

WARNING!

Indicates a potentially dangerous situation

Death or serious injury may result if appropriate precautions are not taken.

- ▶ Action step to escape the situation

CAUTION!

Indicates a potentially dangerous situation

Minor or moderate injury may result if appropriate precautions are not taken.

- ▶ Action step to escape the situation

NOTE!

Indicates impaired work results and/or damage to the device and components

The warnings and safety instructions are an integral part of these instructions and must always be observed to ensure the safe and proper use of the product.

Safety instructions and important information

The device has been manufactured in line with the state of the art and according to recognized safety standards.

WARNING!

Incorrect operation or misuse

Serious to fatal injuries to the operator or third parties as well as damage to the device and other property of the operator may result.

- ▶ All persons involved in the commissioning, maintenance, and servicing of the device must be appropriately qualified and have knowledge of working with electrical installations.
- ▶ Read these operating instructions in full and follow them carefully and precisely.
- ▶ The operating instructions must always be kept to hand wherever the device is being used.

IMPORTANT!

In addition to the operating instructions, all applicable local rules and regulations regarding accident prevention and environmental protection must also be followed.

IMPORTANT!

Labels, warning notices, and safety symbols are located on the device. A description can be found in these operating instructions.

IMPORTANT!

All safety and danger notices on the device:

- Must be kept in a legible state
- Must not be damaged/marked
- Must not be removed
- Must not be covered, have anything stuck on them, or painted over



WARNING!

Tampered-with and non-functioning protection devices

Serious to fatal injuries as well as damage to the device and other property of the operator may result.

- ▶ Never bypass or disable protection devices.
- ▶ Any protection devices that are not fully functional must be repaired by an authorized specialist before the device is switched on.



WARNING!

Loose, damaged, or under-dimensioned cables

An electric shock can be fatal.

- ▶ Use undamaged, insulated, and adequately dimensioned cables.
- ▶ Fasten the cables according to the specifications in the operating instructions.
- ▶ Loose, damaged, or under-dimensioned cables must be repaired or replaced immediately by an authorized specialist.

NOTE!

Installations or modifications to the device

The device may be damaged

- ▶ Do not carry out any alterations, installations, or modifications to the device without first obtaining the manufacturer's permission.
- ▶ Damaged components must be replaced.
- ▶ Only use original spare parts.

Electromagnetic fields

During operation, due to the high electrical voltages and currents, local electromagnetic fields (EMF) occur in the environment around the inverter and the Fronius system components as well as in the area of the PV modules including the supply lines.

In the case of exposure to humans, the required limit values are observed when the products are used in line with the intended use and the recommended distance of at least 20 cm is observed.

If these limit values are complied with, according to current scientific knowledge, no health-endangering effects from EMF exposure are to be expected. If wearers of prostheses (implants, metal parts in and on the body) as well as active physical aids (pacemakers, insulin pumps, hearing aids, etc.) are in the vicinity of components of the PV system, they must consult with the responsible doctor regarding possible health risks.

EMC measures

In certain cases, even though a device complies with the standard limit values for emissions, it may affect the application area for which it was designed (e.g., when there is equipment that is susceptible to interference at the same location or if the site where the device is installed is close to either radio or television receivers). If this is the case, the operator is obliged to take action to rectify the situation.

General

Information on the device

The information on the Fronius Wattpilot must not be removed or painted over. The notices and symbols warn against incorrect operation, as this may result in serious injury and damage.

Symbols on the rating plate:



CE label – confirms compliance with applicable EU directives and regulations. The product has been tested by a specific notified body.



WEEE marking – waste electrical and electronic equipment must be collected separately and recycled in an environmentally sound manner in accordance with the European Directive and national law.



UKCA marking – confirms compliance with applicable UK directives and regulations.



RCM marking – tested according to the requirements of Australia and New Zealand.

Accessories and spare parts

Accessories	Item number
Fronius Wattpilot Flex Pedestal	4,240,196
Fronius Wattpilot Flex Connection Plate	4,240,191
Fronius Wattpilot Flex Gasket Set	4,240,192
10 RFID tags	4,240,181
Type 2 plug holder	4,240,188

Suitable inverters

Compatibility with the connected devices (see list below), suitable data communication, and a Fronius Smart Meter at the feed-in point are prerequisites for using certain Wattpilot functions (e.g., PV surplus).

Suitable Fronius inverters

- Fronius GEN24
- Fronius Tauro
- Fronius Verto
- Fronius Symo Hybrid
- Fronius SnapINverter (except light versions)
- Fronius IG*
- Fronius IG Plus*
- Fronius IG TL**
- Fronius CL*

*Requirement:

- Fronius Datamanager 2.0 (item number 4,240,036,Z), or
- Fronius Datamanager Box 2.0 (item number 4,240,125)

**Requirement:

- Fronius Datamanager Box 2.0 (item number 4,240,125)
-

Suitable generators from third-party manufacturers

Suitable generators can be inverters or wind power plants, for example. A prerequisite for compatibility with external generators is that no other self-consumption controllers (with e.g., battery, power-to-heat) are operated in parallel. This can lead to photovoltaics optimization (PV optimization) malfunctions. The proportion of energy consumed by other loads is not taken into account in the Fronius Solar.wattpilot app, as the power is only known at the grid connection point.

Requirement:

- Fronius Smart Meter IP (at the feed-in point)
- Fronius Smart Meter (at the feed-in point)*

*requires Fronius Datamanager Box 2.0 (item number 4,240,125)

For further information see [Data communication with inverter](#) on page 48.

Webinars and how-to videos

The following link provides current webinars and how-to videos for the Fronius Wattpilot.

[Fronius Wattpilot YouTube playlist](#)

Target group

This document provides detailed information and instructions to ensure that all users can use the device safely and efficiently.

- The information is intended for the following groups of people:
 - **Technical specialists:** People with appropriate qualifications and fundamental electronic and mechanical knowledge, who are responsible for the installation, operation, and maintenance of the device.
 - **End users:** People that use the device in daily operation and want to understand its basic functions.
 - Regardless of any qualifications, only perform the activities listed in this document.
 - All persons involved in the commissioning, maintenance, and servicing of the device must be appropriately qualified and have knowledge of working with electrical installations.
 - The definition of professional qualifications and their applicability are subject to national law.
-

Data security

With regard to data security, the user is responsible for:

- Backing up any changes made to the factory settings
- Saving and storing personal settings

NOTE!

Data security for network and Internet connection

Unsecured networks and lack of safeguards can result in data loss and unauthorized access. Observe the following points for safe operation:

- ▶ Operate inverters and system components on a private, secure network.
- ▶ Keep the network devices (e.g., WiFi routers) up to date with the latest technology.
- ▶ Keep the software and/or firmware updated.
- ▶ Use a wired network to ensure a stable data connection.
- ▶ For security reasons, do not make inverters and system components accessible from the Internet via port forwarding or Port Address Translation (PAT).
- ▶ Use the cloud services provided by Fronius for monitoring and configuration.
- ▶ The optional communication protocol Modbus TCP/IP¹⁾ is an unsecured interface. Only use Modbus TCP/IP if no other secured data communication protocol (MQTT²⁾) is possible (e.g., compatibility with older Smart Meters).

1) TCP/IP - Transmission Control Protocol/Internet Protocol

2) MQTT - Message Queuing Telemetry Protocol

Updates

To ensure that your device is always working optimally and that you benefit from the latest features and security improvements, we recommend that you regularly check for updates.

Check the Fronius Solar.wattpilot app regularly for updates (see also [Firmware update](#) on page 63).

Regular updates keep your device up to date, giving you the best possible performance and security.

Copyright

Copyright of these operating instructions remains with the manufacturer.

Text and illustrations were accurate at the time of printing, subject to change. We are grateful for suggestions for improvement and information on any discrepancies in the operating instructions.

Fronius Wattpilot Flex

Intended use The Fronius Wattpilot Flex Home 11 C6 / Home 22 C6 / Pro 11 C6E / Pro 22 C6E is a permanently mounted charging station for charging electric vehicles for fixed connection to an AC/three-phase network.

The Wattpilot may only be used for the purpose of charging battery-powered electric vehicles and plug-in hybrid vehicles.

The Fronius Wattpilot Flex Pro 11 C6E and Pro 22 C6E satisfy the requirements for calibration law compliance, which means that all measurements and billing of the charged energy are carried out precisely and in accordance with the law.

Intended use also includes complying with all the instructions in these operating instructions.

Foreseeable mis-use The following circumstances are considered to be reasonably foreseeable misuse:

- Any use that is not the intended use or goes beyond the intended use.
- Making any modifications to the Wattpilot that have not been expressly approved by Fronius.
- Installation of components that are not expressly recommended or offered by Fronius.

Scope of supply

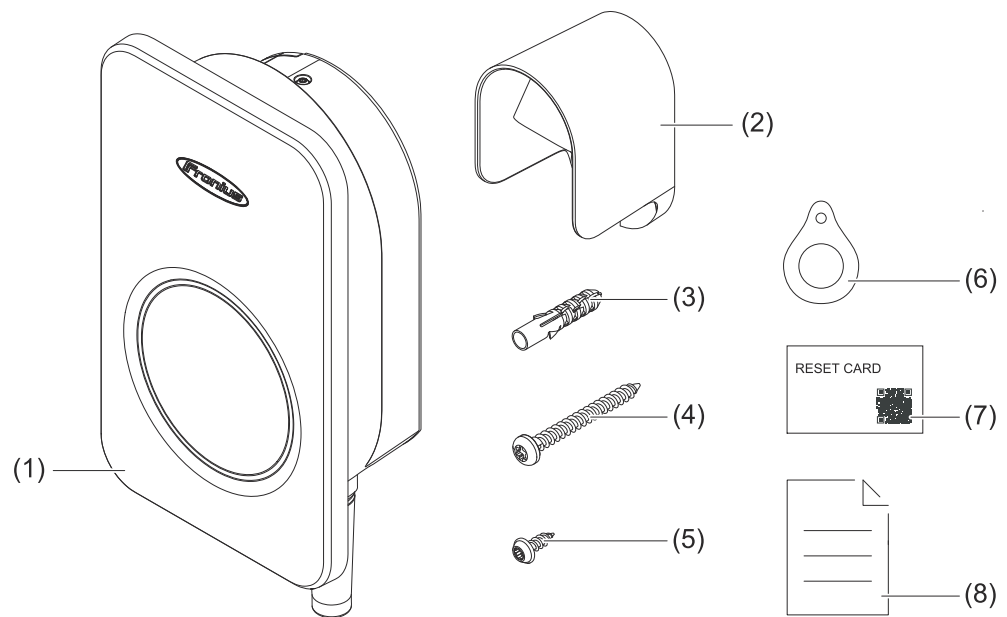

- (1) Device including mounting bracket
- (2) Charging plug holder
- (3) 6 dowels for mounting bracket and charging plug holder
- (4) 6 screws TX20 4.5 x 50 mm for mounting bracket and charging plug holder
- (5) 3 screws TX20 3.0 x 10 mm for mounting the device on the mounting bracket
- (6) 2 ID chips
- (7) Reset card
- (8) Quick Guide

Data communication

The Wattpilot has WLAN (see [Commissioning with app](#) on page 49).

Data communication can also be established via cable (see step 3 in [Mounting the Wattpilot on the wall](#) on page 40). The following connection options are available:

- RJ45
- LSA

Keys and symbols

Product overview

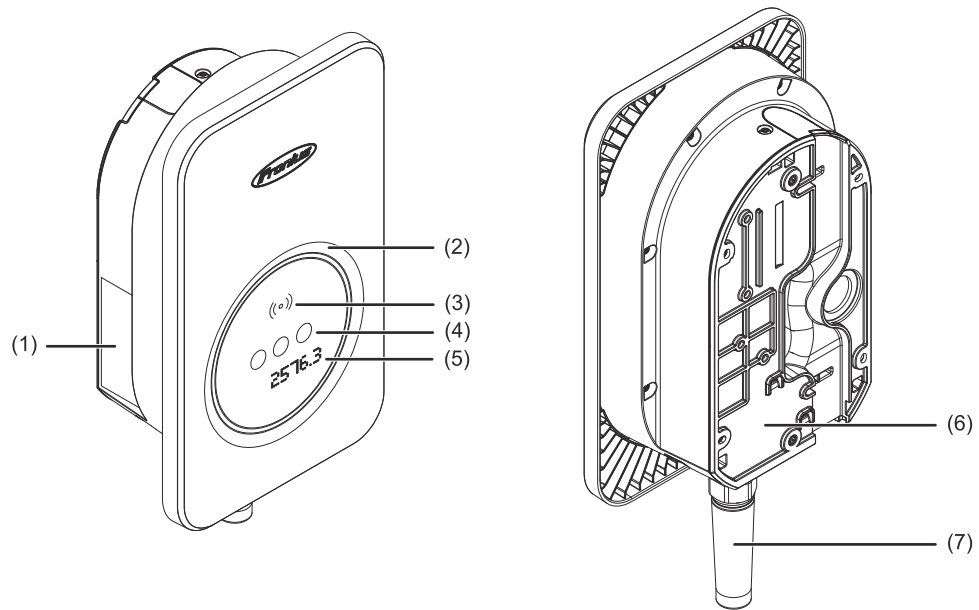

- (1) Rating plate position
- (2) LED status indicator
- (3) Card reader
- (4) Operating mode buttons
- (5) kWh display: Session kWh, Total kWh, Power kWh
- (6) Mounting bracket
- (7) Type 2 charging cable

Card reader



Behind the symbol ((o)) is the card reader for reading ID chips and the reset card.

The card reader uses RFID (radio-frequency identification). RFID is the transmitter-receiver technology for automatic and contactless identification with radio waves.

Operating mode buttons

The buttons are actuated by touch; due to the capacitive touch detection, touching them while wearing gloves can lead to limited results.

The operating mode can be changed by touching the buttons. The following charging modes are available:

Display	Operating mode
	<p>Standard mode</p> <p>The Wattpilot is in Standard mode.</p> <ul style="list-style-type: none"> - The indicator lights up white. - The indicator flashes orange (see chapter Status codes on page 74). - The indicator flashes red (see chapter Status codes on page 74).
	<p>Eco Mode</p> <p>The Wattpilot is in Eco Mode.</p> <ul style="list-style-type: none"> - The indicator lights up white. - The indicator flashes orange (see chapter Status codes on page 74). - The indicator flashes red (see chapter Status codes on page 74).
	<p>Next Trip Mode</p> <p>The Wattpilot is in Next Trip Mode.</p> <ul style="list-style-type: none"> - The indicator lights up white. - The indicator flashes orange (see chapter Status codes on page 74). - The indicator flashes red (see chapter Status codes on page 74).

LED status indicators

The LED status indicator on the Wattpilot indicates whether the system is switched on and shows the current status of the Wattpilot.

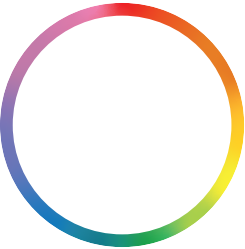
LED	Meaning
	<p>Starting</p> <p>The Wattpilot is starting up or restarting.</p> <ul style="list-style-type: none"> - The indicator lights up in rainbow colors.

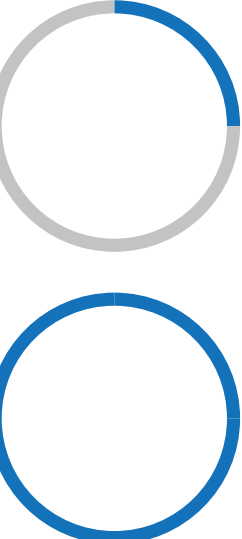
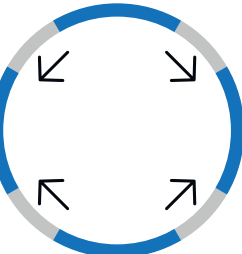
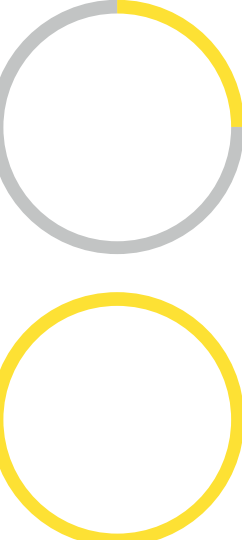
LED	Meaning
	<p>Ready The Wattpilot is ready for operation. The more LEDs light up, the higher the set charging current.</p> <ul style="list-style-type: none"> - A few blue LEDs light up = low charging current (e.g. 8 A). - Several/all blue LEDs light up = high charging current (e.g. 32 A).
	<p>Authentication The Wattpilot must be authenticated via the app or an ID chip.</p> <ul style="list-style-type: none"> - The LEDs light up blue, white LEDs run in a quarter circle from the top and bottom towards each other.
	<p>Wait for vehicle The Wattpilot recognizes the connected vehicle and the set charging parameters. Charging has been enabled by the charging station but not yet started by the vehicle.</p> <ul style="list-style-type: none"> - A few yellow LEDs light up when the charging current is low. - Several/all yellow LEDs light up when the charging current is high.

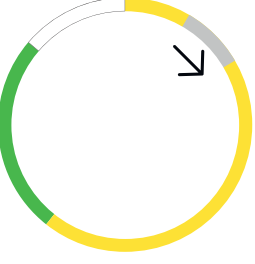
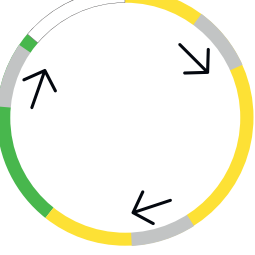
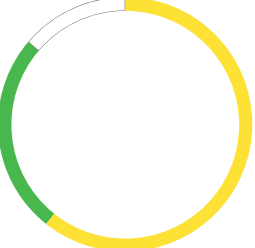
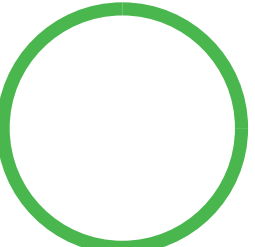
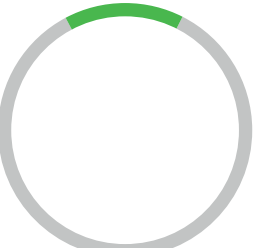
LED	Meaning
	<p>Charging The LEDs indicate the energy sources. Non-illuminated LEDs run in a circle and indicate charging. Either 1-phase or 3-phase.</p> <ul style="list-style-type: none"> - Yellow LEDs = energy from PV surplus - Green LEDs = energy from the battery - White LEDs = energy from the grid
	<p>Charging plug not plugged in The LEDs indicate the energy sources.</p> <ul style="list-style-type: none"> - Yellow LEDs = energy from PV surplus - Green LEDs = energy from the battery - White LEDs = energy from the grid
	<p>Charging finished The charging process is complete.</p> <ul style="list-style-type: none"> - All LEDs light up green.
	<p>ID chip detected The Wattpilot has detected an authorized ID chip.</p> <ul style="list-style-type: none"> - Top LEDs light up green.
	<p>Invalid value The Wattpilot displays an invalid input. The operating mode selection was not permitted or an ID chip was detected but not authorized.</p> <ul style="list-style-type: none"> - Top LEDs light up red.

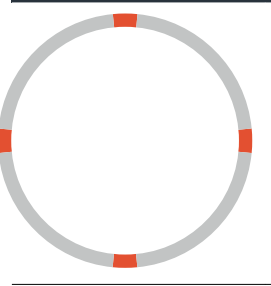
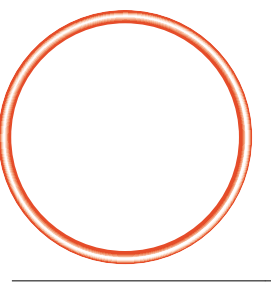
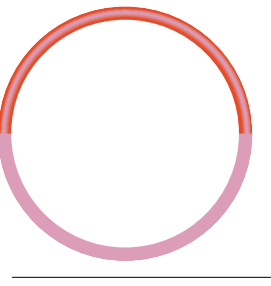
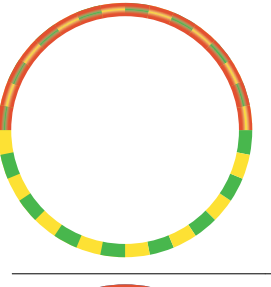
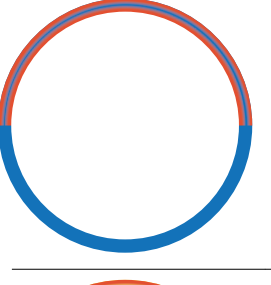
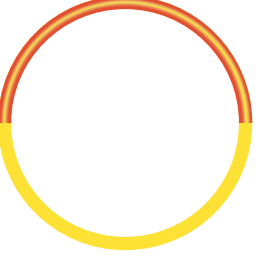
LED	Meaning
	<p>Earthing test deactivated The earthing test is deactivated.</p> <ul style="list-style-type: none"> - LEDs light up at the top, bottom, left, and right.
	<p>Internal communication fault The Wattpilot displays an internal communication error. The error code is displayed in the app. For more information, see Status codes on page 74.</p> <ul style="list-style-type: none"> - All LEDs flash red.
	<p>Residual current detected The Wattpilot has detected a residual current ($\geq 6 \text{ mA}_{\text{DC}}$ or $\geq 20 \text{ mA}_{\text{AC}}$). Restart the Wattpilot. For more information, see Status codes on page 74.</p> <ul style="list-style-type: none"> - The LEDs light up pink, the LEDs at the top flash red.
	<p>Earth fault detected The grounding of the supply line to the Wattpilot is faulty. Check the grounding of the supply line. For more information, see Status codes on page 74.</p> <ul style="list-style-type: none"> - The LEDs light up green and yellow, the LEDs at the top flash red.
	<p>At least one phase of the power supply is missing The phase(s) of the supply line to the Wattpilot has/have failed. Check the phase(s) of the supply line. For more information, see Status codes on page 74.</p> <ul style="list-style-type: none"> - The LEDs light up blue, the LEDs at the top flash red.
	<p>Temperature too high The temperature of the Wattpilot is too high. The charging current is reduced. For more information, see Status codes on page 74.</p> <ul style="list-style-type: none"> - The LEDs light up yellow, the LEDs at the top flash red.

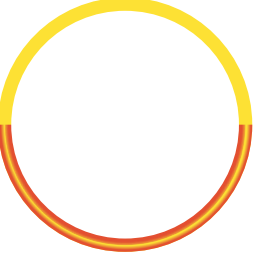
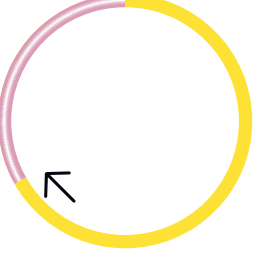
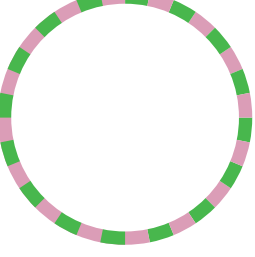
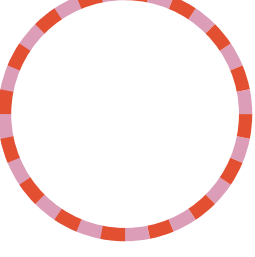
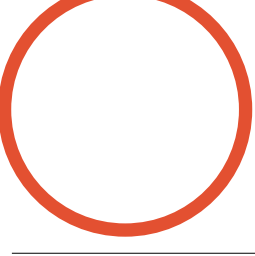
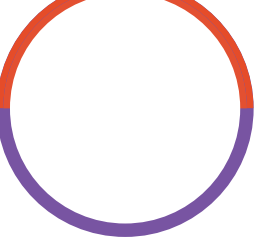
LED	Meaning
	<p>Charge controller error The charge controller is not working properly. For more information, see Status codes on page 74.</p> <ul style="list-style-type: none"> - The LEDs light up red at the bottom and yellow at the top for 1 second.
	<p>Update The Wattpilot firmware is being updated. The update can take several minutes. Do not unplug the charging station.</p> <ul style="list-style-type: none"> - All LEDs flash pink, the progress of the update is indicated by yellow LEDs.
	<p>Update successful</p> <ul style="list-style-type: none"> - The LEDs light up alternately pink and green.
	<p>Update failed</p> <ul style="list-style-type: none"> - The LEDs light up alternately pink and red.
	<p>Reset card detected The Wattpilot has detected the reset card and the settings are being reset.</p> <ul style="list-style-type: none"> - All LEDs light up red for 2 seconds.
	<p>Tamper detection The Wattpilot has detected the device opening. The Wattpilot has not been correctly attached</p> <ul style="list-style-type: none"> - The LEDs light up red at the top and purple at the bottom.

kWh display

The kWh display is located below the operating mode buttons and alternately displays the following values.

Session kWh

Displays the charged energy of the current charging process.

Total kWh

Displays the total charged energy of all charging processes.

Power kW

Displays the current charging power.

ID chip

The ID chip can be used to personalize access to the Fronius Wattpilot. The ID chip is used for authentication and for recording user-specific charging amounts.

In the app settings, authentication for charging can be activated under "Access management" and "Authentication required" (see [Access management](#) on page 59). Charging with authentication activated can be carried out after scanning the supplied ID chip or by providing confirmation in the app. To scan, hold the ID chip directly in front of the card reader of the Wattpilot.

Each ID chip can be assigned a name in the app under "ID chips". The stored charging amount per ID chip can be viewed in this menu (see [ID chips](#) on page 59).

No authentication is required in order to assign the charging amount to the ID chips.

Reset card

The reset card resets all settings (e.g. access management, WLAN, and LED settings) to the factory settings. The device can also be reset using the Fronius Solar.wattpilot app. The taught-in ID chips and the corresponding charging amounts continue to be stored.

The following information is printed on the reset card.

- "Serial number" – serial number of the Wattpilot
- "Hot spot SSID" – WLAN network name of the Wattpilot
- "Hot spot key" – WLAN password of the Wattpilot
- "QR code" – key to connect the app to the Wattpilot WLAN hot spot

Resetting the Wattpilot

- 1 Hold the reset card in front of the card reader.
- 2 All LEDs briefly light up red.

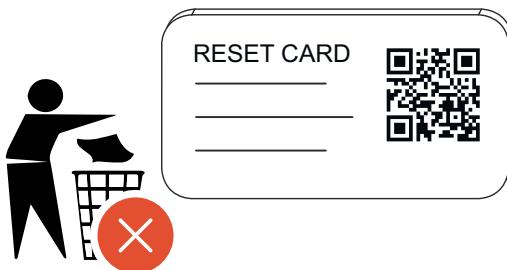

NOTE!

Keep the reset card safe!

The reset card contains all access data.

- ▶ **TIP:** Place the reset card in the supplied self-adhesive transparent bag and keep it in a safe place.

Functions

Overview

The Wattpilot can be used like any other charging station. Actuating an operating mode button (see [Operating mode buttons](#) on page 15) allows the user to switch between the different charging modes (see [Different charging modes](#) on page 27).

Phase changeover

The Fronius Wattpilot can automatically switch between 1-phase and 3-phase charging. The automatic phase changeover enables charging with a low start-up power (1-phase with 1.38 kWh) in the case of a PV surplus. In addition, 1-phase charging has the advantage that the charging power can be regulated in smaller increments (0.23 kW) and a small PV surplus can be used more efficiently. As 1-phase charging is limited by the vehicle, it makes sense to switch to 3-phase charging at a higher PV surplus. This allows higher maximum charging power levels to be achieved.

The phase changeover can be set automatically or manually (see [PV surplus](#) on page 22).

Phase unbalanced load

Unbalanced load management limits the total charging current, which means that the unbalanced load is below the desired value. It is important to comply with the phase unbalanced load limits in order to protect the grid, make charging electric vehicles efficient and comply with the applicable regulations.

The maximum phase unbalanced load can be set by a technical specialist in accordance with the applicable regulations (see [Grid settings](#) on page 60).

NOTE!

Do not exceed the phase unbalanced load!

Select the three-phase power level in such a way that the maximum permissible phase unbalanced load is not exceeded. To do this, amend the settings in the Fronius Solar.wattpilot app under "**Settings**" > "**Grid requirements**".

PV surplus

NOTE!

A minimum charging time of 5 minutes is stored.

To prevent permanent switching of the relays and to increase the service life of the Wattpilot, a minimum charging time of 5 minutes is stored.

The surplus energy of a PV system (photovoltaic system) can be used. The prerequisites for this are a compatible inverter in the same network as the Wattpilot and a Fronius Smart Meter (for more information, see [Data communication with inverter](#) on page 48).

Setting limit values ensures that the available PV surplus power is distributed to the loads. The limit values created allow a PV battery to be sufficiently charged or the energy to be stored in the form of hot water. The surplus PV power is then used to charge a vehicle.

NOTE!

PV surplus regulation.

One Wattpilot per photovoltaic system.

- ▶ The PV surplus regulation works with one Wattpilot per photovoltaic system.
- ▶ If several Wattpilot devices are connected to one inverter, "**Use PV surplus**" may only be activated on one Wattpilot. For all other Wattpilot devices, "**Use PV surplus**" must be deactivated (for more information, see [Cost optimization](#) on page 55).

It is possible to set a **start-up power level** (specified in kilowatts/kW). This must be reached by the photovoltaic system before the Wattpilot starts charging the vehicle with the minimum current.

It is possible to set a **3-phase power level** (specified in kW). This must be reached by the photovoltaic system before the Wattpilot switches from 1-phase to 3-phase charging.

The settings for the start-up power level and 3-phase power level can be made under [Cost optimization](#) in the [Fronius Solar.wattpilot app](#).

The power level can only be regulated in increments of 1 ampere. The table below lists the charging current in amperes (A) and the corresponding charging power for 1-phase and 3-phase charging in kilowatts (kW). 1-phase in 0.23 kW increments, 3-phase in 0.69 kW increments. The values are based on the assumption that the voltage is exactly 230 or 400 V.

- Example: The charging current is increased by 1 A to 7 A.
 - 1-phase: 1.38 kW + 0.23 kW = 1.61 kW
 - 3-phase: 4.14 kW + 0.69 kW = 4.83 kW

Charging current [A]	6	8	10	12	14	16	20	24	32
1-phase [kW]	1.38	1.84	2.3	2.76	3.22	3.68	4.6	5.52	7.36
3-phase [kW]	4.14	5.52	6.9	8.28	9.66	11	13.8	16.56	22

Example

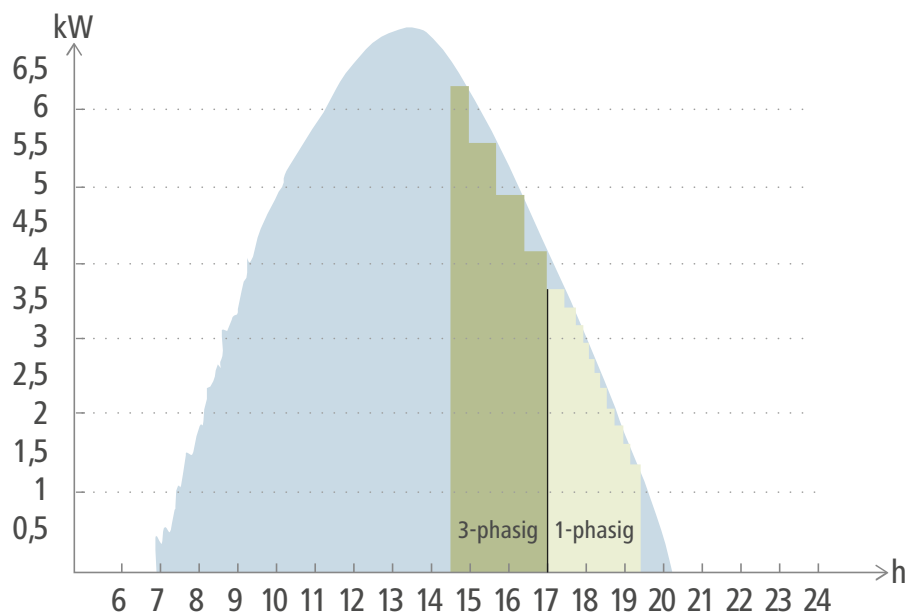

- Photovoltaic generation
- Electric vehicle

The figure illustrates the behavior of the Wattlepilot with a set start-up power level of 1.38 kW and a 3-phase power level of 4.14 kW. If the PV surplus is less than 1.38 kW, the vehicle is not charged.

If the PV surplus is between 1.38 and 4.14 kW, the Wattlepilot regulates the charging power in **0.23 kW** increments.

If the PV surplus is above 4.14 kW, the Wattlepilot switches from 1-phase charging to 3-phase charging and regulates the charging power in **0.69 kW** increments.

NOTE!

The minimum charging power of electric vehicles is usually 1.38 kW.

In the case of smaller photovoltaic systems, we recommend setting the start-up power level below 1.38-kW so that sufficient energy is charged. The electricity that is not covered by the photovoltaic system, however, is drawn from the grid. This results in a power mix of self-consumption and grid supply.

- ▶ A start-up power level below 1.38 kW results in a power mix.

Charging with PV surplus can be activated and adjusted in the Fronius Solar.wattlepilot app (see [Cost optimization](#) on page 55).

Priorities in the system between battery, Ohmpilot and Wattlepilot

The priority of the Wattlepilot can be influenced via the "PV battery limit value" and "Ohmpilot limit value" settings in the Fronius Solar.wattlepilot app (see chapter [Cost optimization](#) on page 55). Depending on the level of the selected limit values, it is possible to define under which conditions the charging of the electric vehicle starts. The temperature limit value of the Ohmpilot can only be used if a temperature sensor is connected to the Ohmpilot. To set the Wattlepilot priority, the energy management priority settings on the user interface of the inverter must also be taken into account.

NOTE!

If no temperature sensor is connected to the Fronius Ohmpilot, a temperature of 0 °C is assumed. If the Wattlepilot is to be prioritized over the Ohmpilot, the "Ohmpilot limit value" must be set to 0 °C. In the event of a sensor break, the Ohmpilot is supplied with power before the Wattlepilot.

Example

The electric vehicle must always be charged with PV surplus before the battery and the Ohmpilot. In the Solar.wattlepilot app, the limit value for the battery is set to 0% and the limit value for the Ohmpilot is set to 0 degrees. The electric vehicle is immediately charged with PV surplus, regardless of the state of charge of the battery or the temperature of the Ohmpilot.

- **System with inverter, Wattlepilot, battery and Ohmpilot**

Priority in the inverter	Wattpilot	Battery**	Ohmpilot
Battery** > Ohmpilot	Priority 3 until SOC* and temperature limit value reached, then priority 1	Priority 1 until SOC*, then priority 2	Priority 2 until temperature limit value reached, then priority 3
Ohmpilot > Battery**	Priority 3 until SOC* and temperature limit value reached, then priority 1	Priority 2 until SOC, then priority 3	Priority 1 until temperature limit value reached, then priority 2

- **System with inverter, Wattpilot and Ohmpilot**

Priority in the inverter	Wattpilot	Ohmpilot
Ohmpilot	Priority 2 until temperature limit value reached, then priority 1	Priority 1 until temperature limit value reached, then priority 2

- **System with inverter, Wattpilot and battery**

Priority in the inverter	Wattpilot	Battery**
Battery**	Priority 2 until SOC*, then priority 1	Priority 1 until SOC*, then priority 2

*SOC - State of Charge of the stationary battery

**Fronius-compatible DC coupled battery

IMPORTANT!

The energy management with the digital outputs (I/Os) on the Fronius inverter **must not** be used for load management of the Wattpilot! The priorities of the loads are not clearly assigned.

Flexible electricity tariff

Tariff zones

If you are a customer of a flexible electricity tariff retailer, you can use the flexible electricity tariff. This is taken into account when using Eco Mode and Next Trip Mode.

Retailer

The flexible electricity tariff can be used if electricity is purchased from electricity retailers and charged for hourly via the electricity exchange, e.g.,

- Lumina Strom hourly
- aWattar hourly
- Tibber

The Wattpilot queries the various retailer tariffs from the electricity exchange directly via the Internet. It is possible to specify a price threshold (Eco Mode price limit) below which charging starts.

IMPORTANT!

The prices displayed show the current tariffs on the electricity exchange. Additional costs may apply depending on the provider.

Example

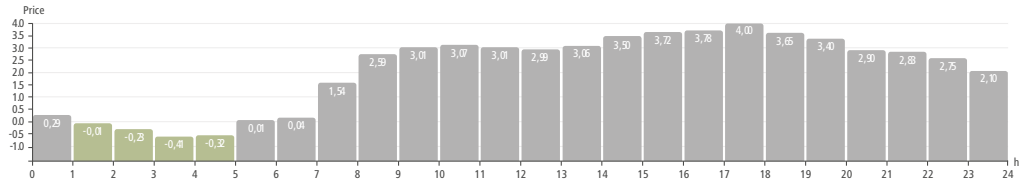

The figure shows the development of the electricity price of an electricity supplier over 24 hours. The hourly tariffs are retrieved from the electricity exchange at a specific time for the next day.

Boost

Prerequisite

To be able to use **Boost Mode**, there must be a stationary battery storage system in the PV system and Eco or Next Trip Mode must be selected.

Function

Activating the **Boost** uses the energy for charging directly from the stationary battery storage system. As a result, low-cost energy can be obtained, even if no PV surplus is available. In the Boost settings, it is possible to set how much residual energy (SOC) should remain in the stationary battery. In addition, you can set whether the charge from the stationary battery should be used once, or for as long as the vehicle is plugged in.

When **Boost** is activated, it can take up to 10 minutes for the battery to discharge at maximum power. If the inverter has already reached the maximum total power (through PV) or the battery cannot be discharged, the Wattpilot still charges with at least 1.4 kW. The minimum SOC of the battery at the inverter must be greater than the "Discharge until" limit value.

Example

Let's imagine that your stationary battery storage system is 80% charged. Due to the current weather conditions, no additional energy is stored. If you now activate the **Boost**, the stored energy will be transferred to your vehicle. Note that the discharging limit of the stationary battery is taken into account (e.g., 20% set = 20% of the energy always remains in the stationary battery storage system). Activating Boost also means that the discharge is continued as long as the vehicle is connected (perform setting in the app). If the weather conditions change and the PV surplus is fed into the stationary battery storage system again, your vehicle will continue to be charged until it is unplugged. A residual amount of energy of 20% is always retained in the stationary battery storage system.

Different charging modes

Standard Mode

In standard mode, charging takes place at the preset amperage (e.g., 16 A). In the app (see [Current level](#) on page 55), the charging current can be adjusted in 1 ampere increments.

Charging with a low charging current is more gentle on the vehicle, whereas charging at a high charging current enables rapid charging. Charging takes place from the grid if necessary.

NOTE!

Standard Mode

In this charging mode, the PV surplus and the flexible electricity tariff are not taken into account.

- ▶ No further settings are required for charging in standard mode.

Eco Mode

In Eco Mode, a vehicle is only charged when low-cost electricity is available. Charging can either take place with cheaply purchased electricity (see [Flexible electricity tariff](#) on page 25) or surplus energy produced by the photovoltaic system (see [PV surplus](#) on page 22). There is no guarantee that charging will occur.

Prerequisite

Charging in Eco Mode is only possible if [PV surplus](#) and/or a [Flexible electricity tariff](#) is activated under [PV surplus](#) in the Fronius Solar.wattpilot app.

NOTE!

Change mode for guaranteed charging.

If there is no surplus generated power or cheap electricity available, charging is not carried out in Eco Mode.

- ▶ For guaranteed charging, change to standard or Next Trip Mode.

Enable

The Eco Mode can be configured under [Cost optimization](#) (see page 55) and activated by pressing the operating mode button or via the Fronius Solar.wattpilot app.

NOTE!

The battery of the photovoltaic system is discharged first!

If the system contains a stationary battery, when the electricity price falls below the threshold, the battery of the photovoltaic system is discharged first in order to charge an electric vehicle before grid current is drawn.

Example

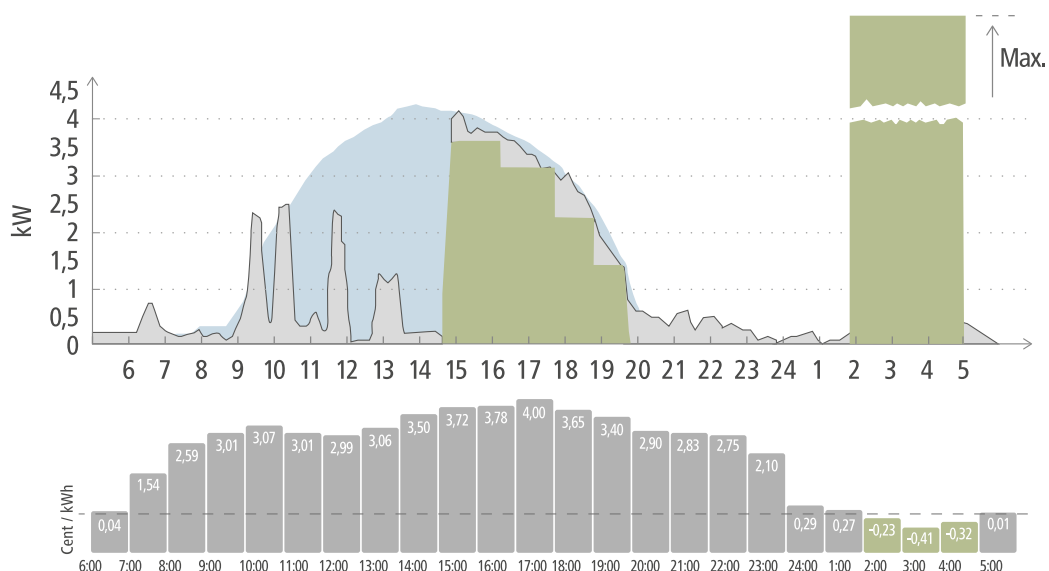

- Photovoltaic generation
- Electric vehicle
- Household consumption

In Eco Mode, the electric vehicle is connected to the Wattlepilot at around 15:00 hrs, as although a fixed additional range for the electric vehicle is not necessary, cheaper electricity is to be used for charging. In the Fronius Solar.wattlepilot app, the PV surplus and/or flexible electricity tariff must be activated and set under cost optimization. Household consumption is covered by photovoltaic generation and the electric vehicle is charged with the PV surplus. Charging takes place using the PV surplus until around 20:00 hrs. Between 02:00 and 05:00 hrs, the electricity price falls below the defined price limit. The electric vehicle is charged with cheap electricity during this period.

Charging in Eco Mode

PV surplus	Price limit	Wattlepilot
No	No	No charging
No	Yes	Max. charging
Yes	No	Charging with PV surplus
Yes	Yes	Max. charging

Next Trip Mode

In Next Trip Mode, a vehicle is charged as cheaply as possible until the end of the self-selected time with the set charging amount. The time charging starts is selected in such a way that the desired charging amount is charged at least one hour before the charge end. Charging takes place at the most cost-effective time window. The PV surplus and flexible electricity tariff settings are taken into account. If the **Stay in Eco Mode** function is activated (for activation see [Next Trip Mode](#) on page 55), the Wattlepilot continues charging with low-cost energy after the set charging amount has been reached.

The charging amount is specified in kilometers and calculated on the basis of an average consumption (18 kWh/100 km). External conditions (such as season, driving speed, vehicle model) may cause deviations in the actual range. When setting the charging amount, the actual state of charge of the electric vehicle battery is not read out. The set charging amount is charged in addition to the charging amount available in the electric vehicle.

Enable

The mode can be set under **Next Trip Mode** in the Fronius Solar.wattpilot app (see [Next Trip Mode](#) on page 55).

After activating the mode, charging is started briefly to calculate a charging schedule taking into account the possible charging power. If no flexible electricity tariff is activated, charging is started at the latest possible time in order to charge with a possible PV surplus and to conserve the battery of the electric vehicle. If no time is provided for the calculation of the charging schedule, charging starts immediately.

NOTE!

Internet connection required if a flexible electricity tariff is activated.

The Next Trip Mode LED flashes red when the flexible electricity tariff (in Next Trip Mode) is activated and there is no connection to the data of the electricity provider. Charging starts at the latest possible time in order to reach the set charging amount.

If the charging cable is disconnected and reconnected while Next Trip Mode is activated, the calculation is repeated and the set charging amount is charged in addition to the existing charging amount. Changes to the settings of the Fronius Solar.wattpilot app result in a recalculation of the charging schedule. If the change is made during Next Trip Mode charging, the range charged up to this point is added to this.

If **Stay in Eco Mode** is activated, the cost optimization settings are also taken into account in Next Trip Mode.

NOTE!

The battery of the photovoltaic system is discharged first.

If the system contains a stationary battery, the battery is discharged to charge the electric vehicle before grid current is drawn.

NOTE!

Orange flashing LEDs if the charging amount cannot be reached or stored.

If the set charging amount cannot be charged in the specified time or if the vehicle cannot store the set charging amount, the LEDs flash orange.

- ▶ Reduce the charging amount or extend the charging time.

Example

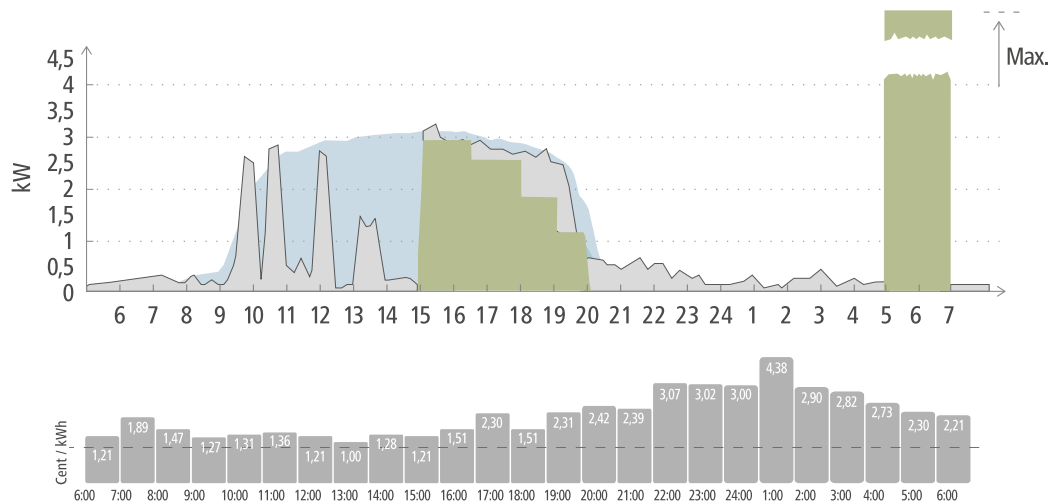

- Photovoltaic generation
- Electric vehicle
- Household consumption

The daily journey to work and back home is 50 km and must start at 08:00 hrs. In the Fronius Solar.wattpilot app, the kilometers and the departure time must be entered once under Next Trip Mode. 18 kWh is used as the basis for the calculation of 100 km. The electric vehicle is plugged in and charged at approximately 15:00 hrs. If PV surplus is available, charging is carried out with PV surplus. The remaining charging amount is guaranteed to be charged in the electric vehicle at the latest possible time. The charge is calculated in such a way that it is completed at the latest one hour before departure.

NOTE!

If there is sufficient energy in the electric vehicle, it is better to use Eco Mode.

If the electric vehicle is sufficiently charged, Eco Mode is the better choice.

► Change to Eco Mode (see [Eco Mode](#) on page 27).

Dynamic load balancing

General

Wattpilot supports dynamic load management, known as Dynamic Load Balancing. To use Dynamic Load Balancing, either a Fronius inverter with Smart Meter, a Fronius Datamanager 2.0 with Smart Meter, or a Fronius Smart Meter IP must be installed in the complete system. In addition, the Wattpilot must be connected to the Internet. The settings implemented can be protected with a technician password (see [Password](#) on page 60).

Dynamic Load Balancing distributes the current while charging with several Wattpilots, depending on their prioritization. The current is distributed dynamically taking into account PV surplus and the maximum reference current in the system. The prioritized vehicles are charged first.

Functional principle

With Dynamic Load Balancing, the maximum reference current can be defined for the house connection point (feed-in point). The energy produced by the photovoltaic system and the loads are automatically taken into account. Any number of Wattpilots can be dynamically controlled. This dynamic control ensures the maximum possible charging current can be used.

Dynamic Load Balancing monitors the available current per phase (including solar power) at the house connection point (feed-in point) and dynamically distributes this to one or more Wattpilots. In this case, the Wattpilots can be supplied with the maximum available current; the maximum current is not exceeded. In addition, the current (reference current) for the Wattpilots can be limited.

NOTE!

Charge 1-phase electric vehicles evenly with multiple Wattpilots.

In the case of multiple Wattpilots, it makes sense to connect the phases differently so that the load is distributed evenly among 1-phase electric vehicles.

- ▶ Connect the phases differently.

The maximum reference current must be set to match the post-meter fuse.

Control system example

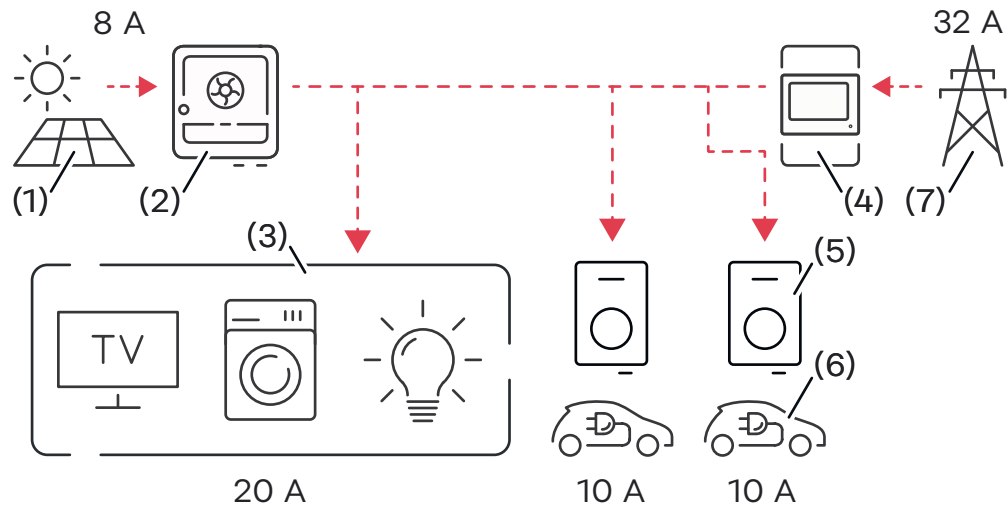

- (1) Photovoltaic system
- (2) Inverter
- (3) Loads (e.g., TV, washing machine, light)
- (4) Smart Meter
- (5) Fronius Wattpilot
- (6) Electric vehicle
- (7) Grid

In the **example of a control system**, 32 A are drawn from the public grid and 8 A are generated by the PV system, for a total of 40 A of available electricity. The household loads require 20 A, and the remaining 20 A are dynamically divided among the connected Wattpilots to enable charging of, for example, two electric vehicles with 10 A each.

NOTE!

Charging is interrupted or does not start.

If Dynamic Load Balancing is activated, charging interruptions may occur. Some electric vehicles encounter problems when starting charging again.

Priority

In the case of systems with multiple Wattpilots, charging priorities can be set. The charging stations (electric vehicles) with a higher priority are supplied with current first; charging stations with a lower priority have to wait. If there is current left over, it is shared among the lower-priority Wattpilots.

The vehicles that are to be charged first and with the maximum available current must be assigned a high priority. A low priority can be assigned to vehicles that should wait to charge until sufficient current is available.

In the case of Wattpilots with the same priority, the available current is shared equally.

Example 1

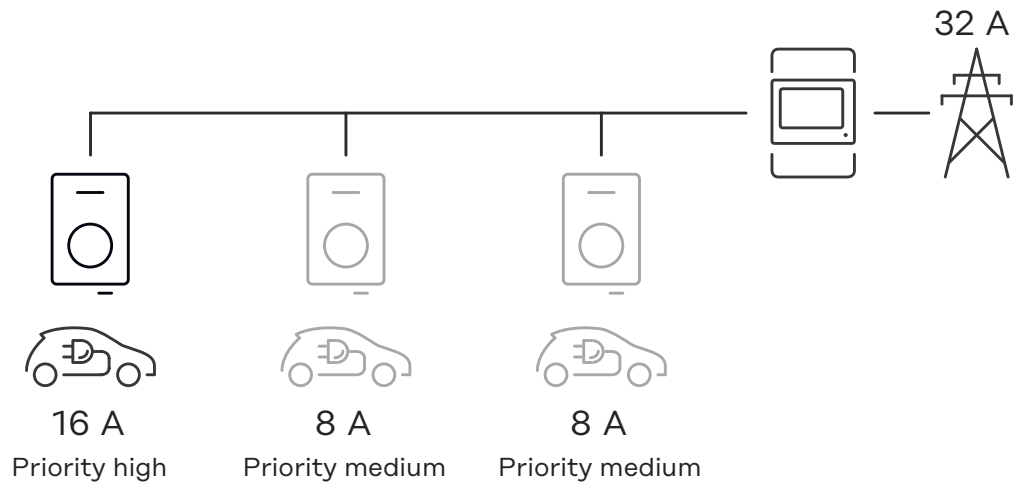

Distribution of the charging current with three Wattpilots with different priorities (one with high priority, two with medium priority).

Example 2

Distribution of the charging current with three Wattpilots (X, Y, Z) with the same priority. Each Wattpilot is assigned the minimum charging current (unless the minimum charging current is no longer available). If there is charging current left over, it is distributed wherever possible, starting with the first Wattpilot in the loop.

Wattpilot X has a minimum charging current of 6 A, Wattpilot Y 10 A and Wattpilot Z 6 A. There is 15 A of charging current to be distributed. The charging current is distributed as follows.

1. X receives 6 A, 9 A remains.
2. Y receives nothing as the minimum charging current of Y is 10 A. Y is set to 0.
3. Z receives 6 A, 3 A remains.
4. The loop starts all over again.
5. X receives 7 A, 2 A remains.
6. Y receives nothing as the charging current has already been set to 0 in the first loop.
7. Z receives 7 A, 1 A remains.
8. The loop starts all over again.
9. X receives 8 A, 0 A remains.

The 15 A charging current was distributed among the equally prioritized Wattpilots and charged. As soon as charging current is available again, the electric vehicle is charged at Wattpilot Y.

Installation and Startup

Installation location and position

Choice of location

The following criteria must be taken into account when choosing a location.



The Wattpilot is suitable for outdoor operation without direct sunlight.



The Wattpilot is suitable for operation in a well-ventilated indoor area.



Do not operate the Wattpilot in areas with increased danger as a result of ammonia gases.

The Wattpilot is suitable for operation indoors and outdoors.

For environmental conditions, see [Technical data](#) on page 68.

CAUTION!

Beware of warping of the mounting bracket on uneven surfaces.

An uneven surface can cause the mounting bracket to warp, making it impossible to attach the Wattpilot.

- ▶ Select a suitable location on an even surface.

NOTE!

Failure to comply with the reporting obligation may lead to legal consequences.

Failure to comply with the reporting obligation, may result in sanctions or fines being imposed.

- ▶ Check with the grid operator whether there is an obligation to report charging stations in the destination country.
- ▶ If necessary, report the charging station to the responsible grid operator in order to avoid legal consequences.

Installation position

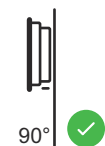

The Wattpilot is designed to be installed vertically on a vertical, level wall.



- Do not install the Wattpilot horizontally.
 - Do not install the Wattpilot on a sloping surface.
 - Do not install the Wattpilot on a sloping surface with the connection facing down.
-

NOTE!

To protect the Wattpilot from physical contact, it must be mounted at least 140 cm above the ground.

Support foot

The Wattpilot can be mounted on the optionally available support foot, which allows for flexible positioning. You have the option of attaching one or two charging stations to the support foot.

NOTE!

When positioning the support foot, please note the permissible choice of location.

Installation

Safety



WARNING!

Installation and commissioning must only be carried out by a qualified electrician!

Observe the requirements for the qualification of the technical personnel. Know and observe the 5 safety rules for working on electrical systems.

- ▶ Disconnect.
- ▶ Secure against anyone inadvertently turning on the power again.
- ▶ Ensure the system is no longer live.
- ▶ Ground and short circuit.
- ▶ Cover or shield neighboring parts that are energized.



WARNING!

Danger due to open or damaged housing.

This can result in severe personal injury and damage to property due to high voltage and/or fire.

- ▶ Do not use the device if the housing is damaged or open.
- ▶ Send in the device for repair.



WARNING!

Danger from loose parts in the housing.

This can result in severe personal injury and damage to property due to high voltage and/or fire.

- ▶ Do not use the device if there are loose parts in the housing.
- ▶ Send in the device for repair.



WARNING!

Danger due to cables.

Damaged or exposed cables can result in severe personal injury and damage to property.

- ▶ Do not use the device if the cables attached to or plugged into the device are damaged.
- ▶ Adequately support the weight of the device with the charging cable.
- ▶ Provide mechanical relief for the cables.
- ▶ Lay the charging cable securely to avoid the risk of tripping over the charging cable.



WARNING!

Danger due to wet or dirty plugs!

Charring caused by prolonged usage can result in severe personal injury and damage to property.

- ▶ Only mount the device vertically.
- ▶ Dry wet plugs in a de-energized state.
- ▶ Clean soiled plugs in a de-energized state.

⚠ WARNING!

Danger from gassing vehicle batteries!

This can result in serious injury.
▶ Only use in well-ventilated areas.

⚠ WARNING!

Danger from driving away with the charging cable connected!

This can result in severe personal injury or damage to property.
▶ Disconnect the charging cable from the electric vehicle before driving away.
▶ Do not bypass the safety device of the electric vehicle.

Never pull the plug out of the plug connection by the cable!

Observe the specifications of the grid operator regarding 1-phase charging and the asymmetrical network load that may result.

The device has a built-in residual current protection module with residual current detection (20 mA AC and 6 mA DC). A separate residual-current circuit breaker and an automatic circuit breaker must be connected upstream for each Wattpilot.

Observe the national installation standards!

Mounting the Wattpilot on the wall

Make sure that the mounting bracket is not warped or deformed.

1

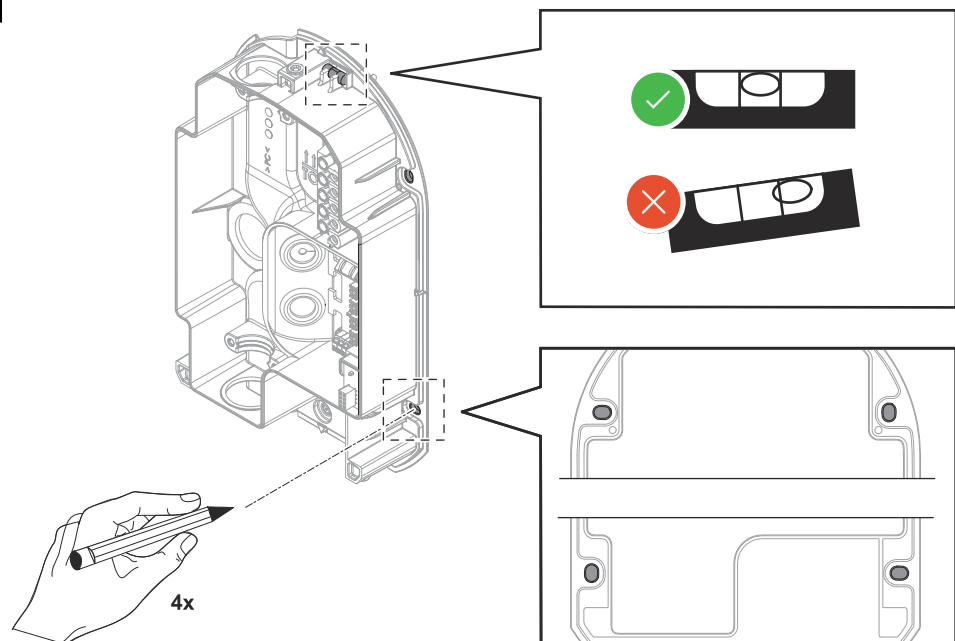

Mark the drill holes 4 times. To align horizontally, use the level at the top.

2

Drill 4 holes.

3

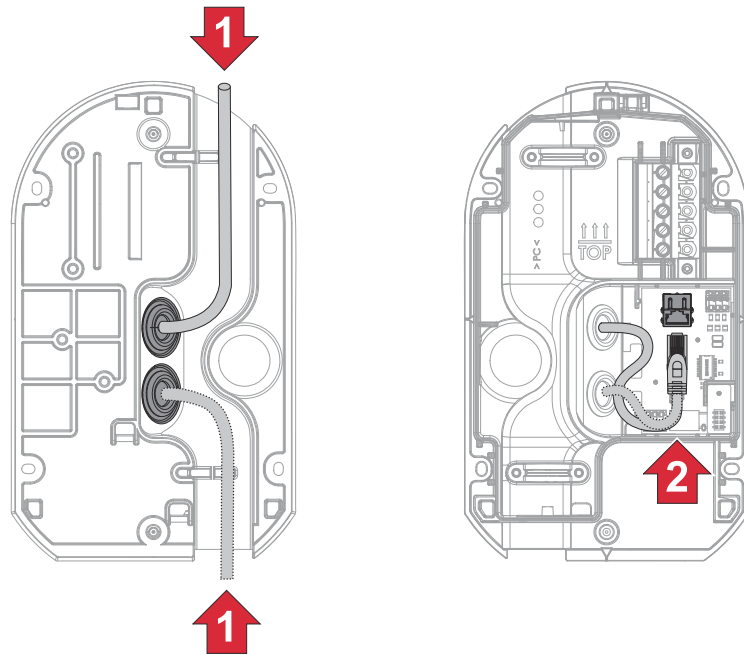

Data communication via cable

For data communication, insert the CAT5 cable into the housing. Establish data communication via RJ45 or LSA, or connect via WiFi.

NOTE!

Thread in the mains cable.

Please note that feeding in the mains cable from the rear must take place before final installation of the device on the wall.

4

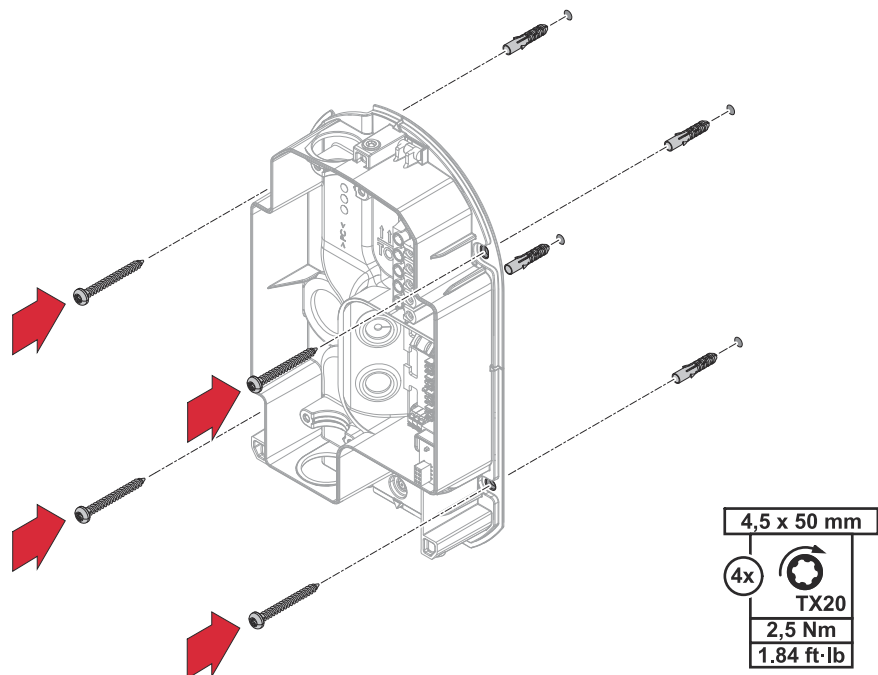

Place dowels in the bores and fasten the mounting bracket with screws (see [Scope of supply](#)).

5

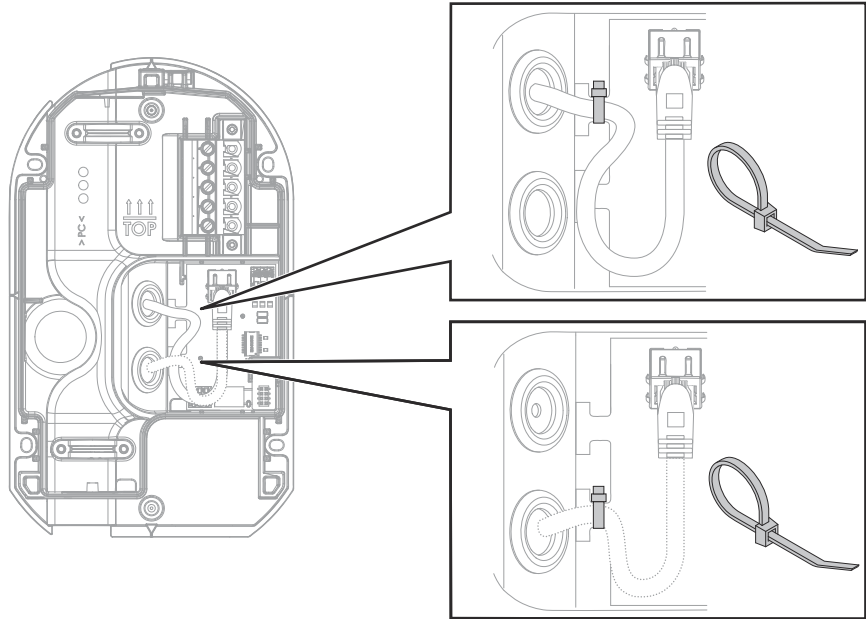

Using a cable tie, secure the Ethernet cable in the position shown above.

Fitting the charging plug holder

To hook in the charging cable, mount the charging plug holder as follows.

1

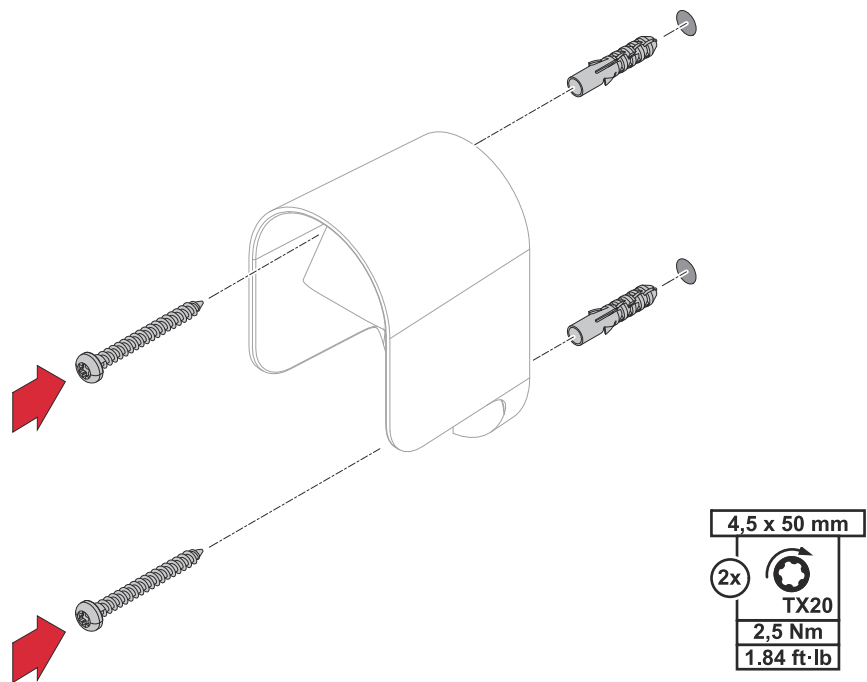

Mark the drill holes twice and drill 2 holes. Place dowels in the holes and secure the cable bracket with screws.

Installing the grid connection

During installation, the mains cable must be installed by a technical specialist in accordance with national standards. The fuse protection for the mains lead must be dimensioned in accordance with the device technical data.

WARNING!

Danger from mains voltage!

An electric shock can be fatal.

- ▶ Always make sure the circuit is disconnected and de-energized before carrying out any connection work.
- ▶ Have the connection work performed by an authorized electrician.

WARNING!

Incorrect or insufficient connection of the phases.

This can result in electrical shocks, short circuits, damage to the device or fire hazards.

- ▶ For 1-phase operation, use phase L1.
- ▶ To supply current to the Wattlepilot, a phase must be connected to L1.
- ▶ The unused phases L2 and L3 must be insulated (contact protection)!

Mains cable from the rear

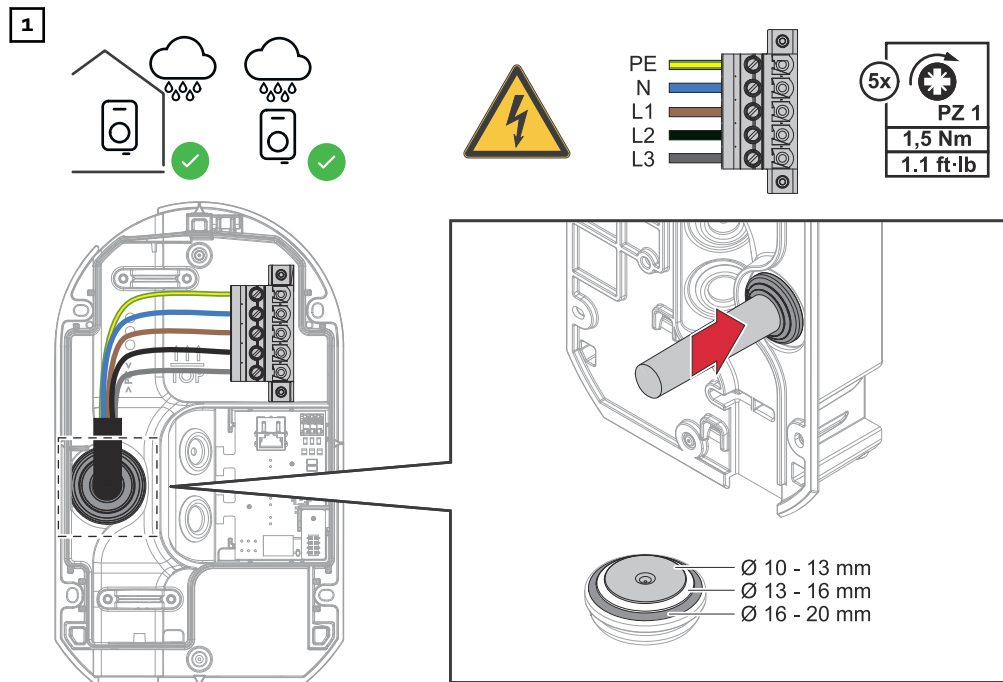

Insert the 5-pin mains cable into the device from the rear through the opening. Fasten the individual wires according to the illustration. Adjust the rubber grommet to the cable cross-section. The rubber grommet protects the device from water ingress.

Mains cable from above

NOTE!

Grid connection from above is only permitted indoors.

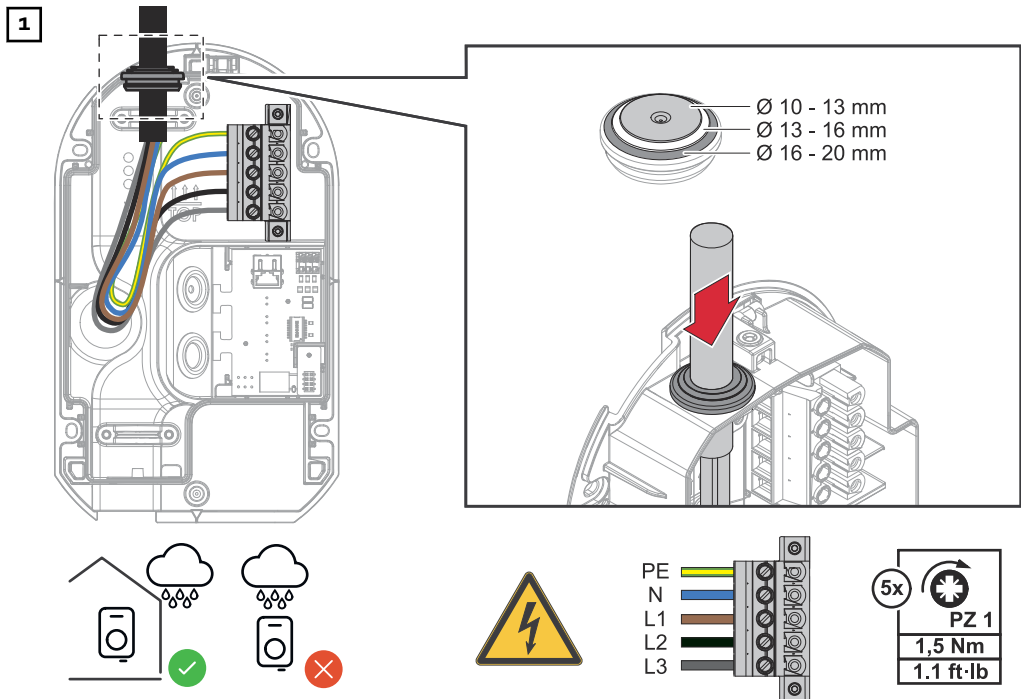

Insert the 5-pin mains cable into the device from above through the opening. Put the rubber grommet over the mains cable to seal it.

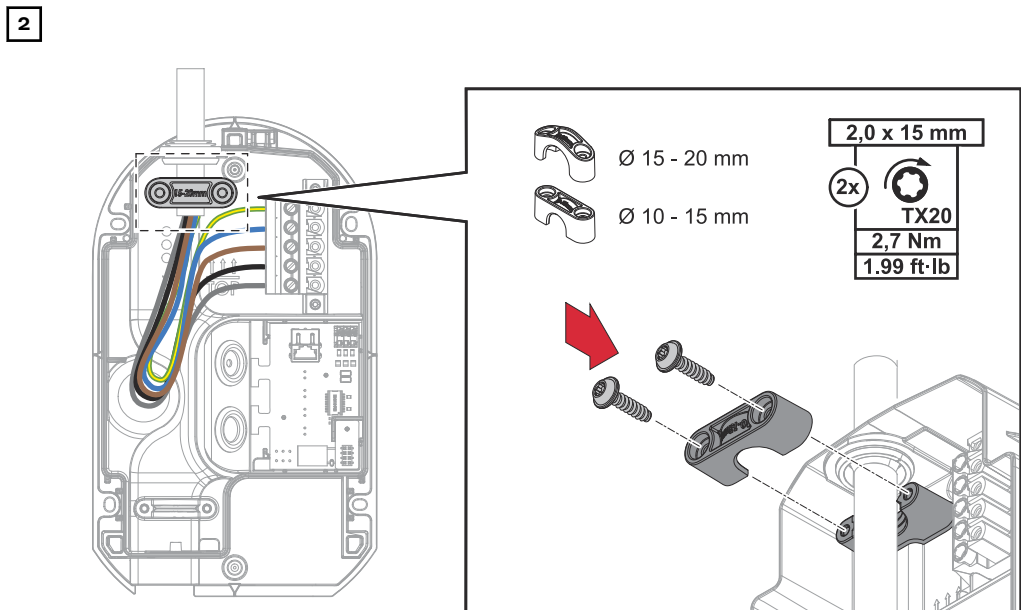

Secure the individual wires of the mains cable as shown in the illustration. Fit an appropriate strain-relief device (10–15 mm or 15–20 mm).

Mains cable from below

1

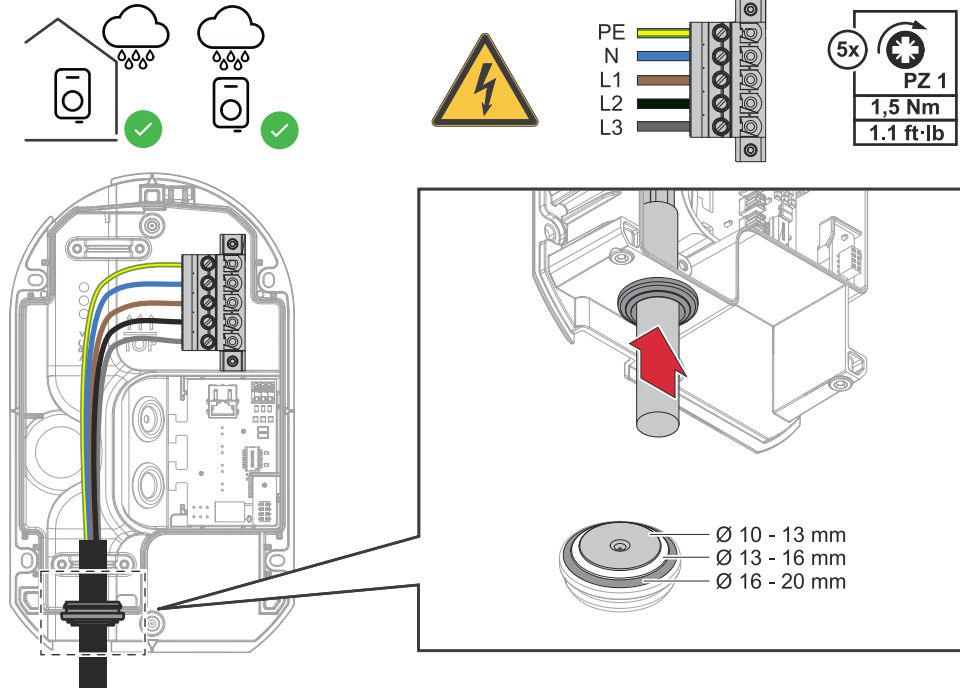

Insert the 5-pin mains cable into the device from below through the opening.

2

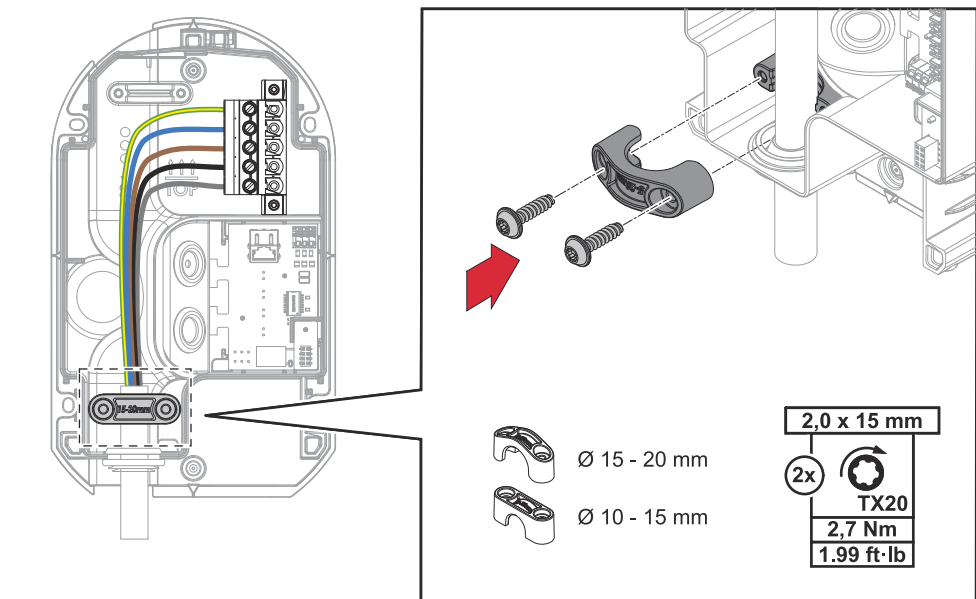

Secure the individual wires of the mains cable as shown in the illustration. Fit an appropriate strain-relief device (10–15 mm or 15–20 mm).

Closing the device

Mains cable from above

1

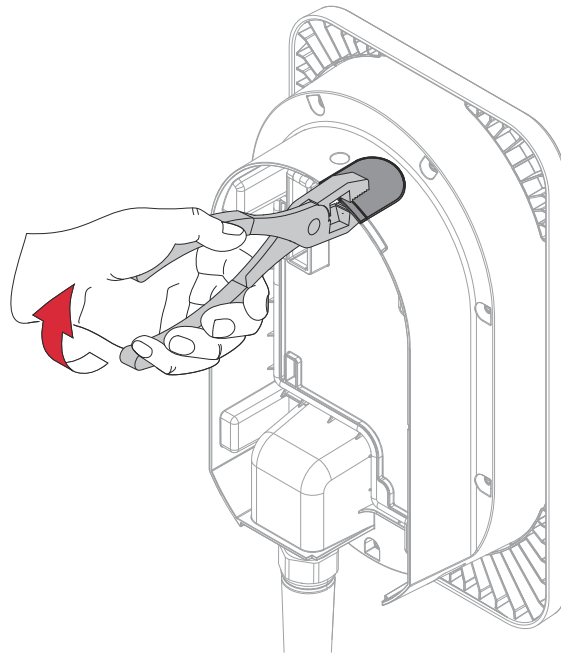

If the mains cable is inserted into the device from above, it is necessary to break out the marked area on the housing using a suitable tool.

Fitting the housing cover

1

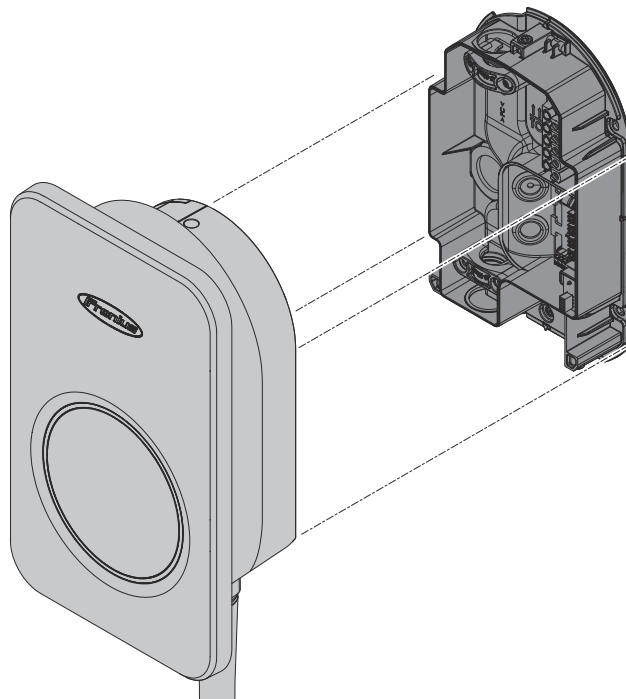

Place the housing cover onto the device as shown.

2

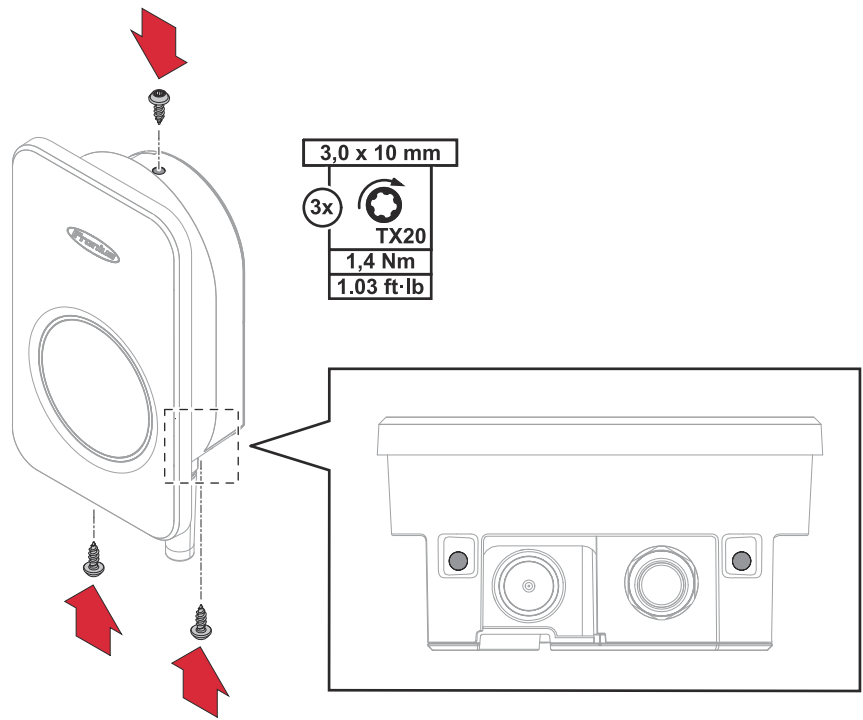

Secure the housing cover with 3 screws TX20 3.0 x 10 mm.

Commissioning

Starting the charging process

How a charging process is started depends on whether authentication with an ID chip is required or not. Authentication can be managed in the Fronius Solar.watt-pilot app under **Settings > Access control**. Further information can be found under [Access management](#) on page 59.

To start the charging process, proceed as follows:

- 1 Connect the type 2 charging plug to the vehicle.
- 2 If authentication is required:
Hold the ID chip in front of the card reader on the Wattpilot.

✓ *The charging process can be started.*

Stopping charging

When the vehicle battery is fully charged, the vehicle stops charging.

Proceed as follows:

- 1 Disconnect the charging plug from the vehicle.
- 2 Wind up the charging cable on the Wattpilot and hang the charging plug in the charging plug holder.

Aborting the charging process prematurely

- In the vehicle via the "cable release" function
 - In the app by clicking on "Stop" (see chapter [Homepage](#) on page 53).
-

Backup power mode

NOTE!

It is recommended that the Wattpilot is connected outside the emergency power loads of a PV system!

If the charging current per phase cannot be covered by the backup power, connect the Wattpilot outside the backup power loads. If the Wattpilot is connected in the backup power circuit of a PV system and the total power of a phase is exceeded, the inverter switches off the backup power. The electric vehicle must be disconnected and the backup power must be acknowledged (see inverter operating instructions).

IMPORTANT!

Check whether the electric vehicle allows charging at 53 Hz.

Data communication with inverter

Charging with PV surplus (see [PV surplus](#) on page 22) is possible with a supported Fronius inverter and Fronius Smart Meter IP, to which a primary Fronius Smart Meter is connected. As soon as an inverter is in the network, the Wattpilot automatically pairs with the first inverter found.

Another inverter can be paired via the Fronius Solar.watt-pilot app (see [Cost optimization](#) on page 55).

Requirements

- The inverter is supported and has a suitable data interface (see [Suitable inverters](#) on page 10).
- The Fronius Solar API must be activated.
To do so, on the user interface of the inverter in the **Communication > Solar API** menu area, activate the **Activate communication via Solar API** function.
- The Wattpilot and the inverter are in the same network.
- A primary Fronius Smart Meter must be connected to the inverter at the feed-in point. If there are multiple inverters with a primary Fronius Smart Meter in the network, only one of them may be paired.

Commissioning with app

The Fronius Solar.wattpilot app can be used to commission, configure, operate, visualize, and update the Wattpilot. The app is available for Android™ and iOS®.

NOTE!

To ensure the security of your device and your data, we recommend that you only use the device on secured networks and not on public networks; this ensures that your device is optimally protected and you can enjoy a secure user experience.

NOTE!

To guarantee optimal performance and security of your device, we recommend that you check for and install software updates regularly. Updates include important improvements and security fixes that increase the functionality and protection of your device. Therefore, regularly check whether updates are available and perform available updates.

Download

The Fronius Solar.wattpilot app is available on the following platforms.



Launching the app

- 1 Open the Fronius Solar.wattpilot app on the end device and follow the Setup wizard.
- 2 Read and accept the terms and conditions of use.
- 3 Click on "Connect".

NOTE!

Access for the Fronius Solar.wattpilot app must be allowed for end devices with an iOS operating system.
iOS settings > Privacy > Local network > Fronius Solar.wattpilot > Allow access to local network

Setting up the WLAN**IMPORTANT!**

In Germany, to comply with the documentation obligation set out in Section 14a of the EnWG (law on the fuel and electricity industries) the Wattpilot must be permanently connected to the Internet in order to be able to verify implementation of the external control commands.

Adding a Wattpilot

New or connected Wattpilot devices can be added in the Fronius Solar.wattpilot app.

- 1** Click on the "+" symbol.
- 2** Click on "Add" for the connected Wattpilot.
- 3** Follow the further instructions in the app.

Fronius Solar.wattpilot app

Charging

Homepage

The figure below shows the "**Charging**" homepage of the Fronius Solar.wattpilot app.

(1) Touch the app icon and go to the "**Select Wattpilot**" page. Add a new Wattpilot by pressing the "+" icon.

(2) Views in the main window:

- "**Power**"
- "**Details**"
- "**Forecast**"

(3) **Power:**
The current charging current and the charging time are displayed.

- Touch circle: Charging is started/stopped
- Touch buttons below: Call up "**Mode**", "**Current**", or "**Next Trip Mode**"

(4) Enable or disable "**Boost**", as well as other settings. Details of the current charging process are displayed under "**Status**" and "**Range**".

(5) The following pages can be called up:

- "**Charging**"
- "**Settings**"
- "**Internet**"

Energy per user

Under "**Range**", a list showing the consumption of the registered ID chips can be called up via "**Energy per user**". By entering "Total", the list can be downloaded as a *.csv file. The following data are displayed in the file:

- **Session number:** Sequential number. A session is the period of time between connecting and disconnecting the charging cable.
- **Session identifier:** Unique identification number.
- **ID chip:** Information about the registered ID chip. No entry if loaded without ID chip.
- **ECO operating mode [%]:** Proportion of the charged energy from Eco Mode as a percentage.
- **Next Trip operating mode [%]:** Proportion of the charged energy from Next Trip Mode as a percentage.
- **Start:** Start date and time from which the charging cable is connected.
- **End:** End date and time when the charging cable is disconnected.
- **Total duration:** Period of time during which the Wattpilot is in use.
- **Duration of active current flow:** Period of time during which energy was being charged into the vehicle.
- **Max. power [kW]:** Maximum power in kilowatts reached during charging.
- **Max. current [A]:** Maximum current in amperes reached during charging.
- **Energy [kWh]:** Indicates the charged energy in kilowatt hours.
- **Meter reading start [kWh]:** Indicates the charged energy in kilowatt hours at the start of the charge.
- **Meter reading end [kWh]:** Indicates the charged energy in kilowatt hours at the end of the charge.

Settings

Next Trip Mode

Charging is carried out as cheaply as possible using surplus PV current (see [PV surplus](#) on page 22) and a flexible electricity tariff (see [Flexible electricity tariff](#) on page 25).

- 1 Under "**Settings**", click on the "**Next Trip Mode**" button.
- 2 Specify the "**Minimum amount of charging**" in kilometers (km) or kilowatt-hours (kWh).
 - 100 km correspond to 18 kWh as standard. The actual consumption over 100 km varies from vehicle to vehicle and can be adjusted under "**Consumption over 100 km**".
- 3 Enter the time by which charging must be complete.

Activating "Next Trip Mode"

- Directly on the Wattpilot by pressing the pushbutton (see [Operating mode buttons](#) on page 15).
- In the app, under "**Charging**", click on the "**Mode**" button and activate "**Next Trip Mode**".

Activating "Eco Mode after Next Trip Mode"

After reaching the set range, the Wattpilot remains in **Next Trip Mode** and continues charging with the **Eco Mode** settings.

Current level

The current level (charging power) can be adjusted in the app in ampere steps.

NOTE!

If charging in an unknown infrastructure, always charge with the lowest charging current (e.g., 6 A or 10 A).

NOTE!

A slow charge with a low amperage is gentler on the battery of the vehicle. This can extend the service life of the battery.

Cost optimization

Under "**Cost optimization**", you can activate taking the electricity tariff into account (see [Flexible electricity tariff](#) on page 25) and the use of PV surplus (see [PV surplus](#) on page 22). You can also customize the settings listed below.

Use flexible electricity tariff

Enable or disable, and select the appropriate country from the list below. Either select the flexible electricity tariff of a provider if available, or select a tariff zone.

Eco Mode price limit

If the flexible electricity tariff is enabled in Eco Mode, charging only begins when the specified electricity price is below this value. If the electricity price is above this value, charging does not take place.

NOTE!

In Next Trip Mode, the cheapest charging times in the available time span are taken into account instead of this value.

Use PV surplus

Activate or deactivate. If **"Use PV surplus"** is enabled, the Wattpilot uses the surplus PV energy for charging.

Inverter

Select a coupled inverter.

PV battery threshold

If a battery is integrated into the PV system, the **"Discharge PV battery"** function can be enabled and the following limit values can be set:

- **"Vehicle charges from"**: If the set SoC of the battery is exceeded, all of the surplus PV energy can be used for the charging process.
- **"Discharges until"**: The Wattpilot discharges the battery until the set SoC is reached.
- **"Limit time"**: The battery is only discharged from the Wattpilot during the time period set for the charging process.

NOTE!

The set limit values are only active in Eco Mode and Next Trip Mode if the use of flexible electricity tariffs is disabled.

Ohmpilot limit value – optional

If a Fronius Ohmpilot with a temperature sensor is installed in the PV system, a limit value for the temperature can be set here. Below the set value, preference is given to heating with the available energy. Above this value, the vehicle is charged instead of heating with the Ohmpilot. The temperature can still increase slowly.

PV surplus– advanced settings

You can set a **Start-up power level** from which the PV energy is used for charging in the advanced settings. Vehicles require a certain minimum power to charge.

- **Start-up power level**: If "0" is set, the Wattpilot starts charging even if no PV surplus is available.
- **Zero feed-in**: No PV power is fed into the grid. If zero feed-in is activated in the inverter, it must also be activated on the Wattpilot.

Vehicles are regulated in increments, so there may be deviations in the use of PV surplus. The following settings can be made under **Control behavior**.

- **Prefer from grid**: The Wattpilot prefers consumption over feed-in from the grid.
- **Standard**: The Wattpilot allows for both consumption and feed-in.
- **Prefer to grid**: The Wattpilot prefers feed-in over consumption from the grid.

NOTE!

If zero feed-in is activated, the prioritization of system components cannot be guaranteed. PV optimization control may be restricted.

Vehicle– advanced settings

During smart charging, the charging process can be interrupted or the charging current reduced to meet certain charging conditions. Set vehicle-specific settings to ensure the smart charging process runs smoothly.

- **Choose car:** Use this setting to enable the optimized standard settings of different vehicle models.
- **Minimum current:** Some cars will not resume charging after an interruption. To prevent an interruption, the **Minimum charging current** can be set.
- **Forced charging interval:** In the case of cost-optimized charging, the Wattpilot interrupts the charging process if the electricity price is too high. Some cars will not tolerate interruptions and will not continue charging after prolonged interruptions to the charging process. In this case, the charging process must be started regularly for a short time.
- **Allow charging pause:** Some cars will not resume charging after an interruption. Charging interruptions are prevented if this option is deactivated.
- **Simulate unplugging:** Some cars need to be disconnected for a while if there has been an interruption during cost-optimized charging. This function simulates a disconnection before charging continues.
- **Charge pause:** Some vehicles need a certain time after an interruption in charging before they can start charging again.
- **Minimum charging time:** Set the minimum amount of time the car must be charged after starting charging.
- **Choose phase switch:**
 - **Automatic:** A power level can be set, from which 3-phase charging takes place. If "0" is set, the Wattpilot immediately starts 3-phase charging.
 - **Only 1-phase:** There is one phase available for charging.
 - **Only 3-phase:** There are three phases available for charging.
- **3-phase -power level:** Set a power level that must be reached by the photovoltaic system before the Wattpilot switches from 1-phase to 3-phase charging. If the available power is greater than the set value, the Wattpilot immediately activates 3-phase charging. Automatic switching can be deactivated in the car settings.
- **Phase switch delay:** The phase switch is carried out if the "3-phase power level" is permanently exceeded or fallen short of in this time period.
- **Phase switch interval:** Minimum time between the phase switches.

NOTE!

If a vehicle is not listed, no specific charging behavior is known. All defaults can be adjusted.

- ▶ Select the standard charging behavior.

Charging timer

The "**Charging timer**" setting limits charging to specific times. A start and end time must be specified for this. Several time windows can be set. The following can be set:

- The time (start and end time)
- The days of the week

Set whether charging with PV surplus is allowed at the defined time windows (with permitted or blocked charging).

- Allow charging + PV surplus
- Block charging + PV surplus

NOTE!

Behaviour with activated Eco Mode or Next Trip Mode:

If charging is not allowed by the charging timer for a certain period of time, Eco Mode and Next Trip Mode are also blocked for this period.

If the charging timer does allow charging in a certain period of time but the settings for Eco Mode or Next Trip Mode are not met, charging will not occur.

Load balancing Proceed as follows to call up the "**Grid settings**".

Technician password (if set)

- 1 Click on "**Grid settings**".
- 2 Enter the "**Technician password**".
- 3 Click "**OK**".

Dynamic load balancing can be selected and set under "Load balancing".

Load balancing off

With this setting, no load balancing is carried out by the Wattpilot.

Dynamic load balancing

For general information on Dynamic load balancing, see [Dynamic load balancing](#) on page 31. Dynamic load balancing monitors the current at the reference point. It dynamically limits the current for up to three Wattpilots to ensure that the maximum reference current is not exceeded. The following settings can be made:

- **Maximum reference current**
Set the maximum reference current for the power connection, which must not be exceeded.
- **Max. current of supply line**
Limit the total current of all Wattpilots so that the mains lead is not overloaded.
- **Phase assignment**
The Smart Meter monitors each phase. For load balancing to work properly, the phase assignment of the Wattpilot must be set in relation to the Smart Meter. This causes the correct Wattpilot to be regulated back when the current of a phase is exceeded.
- **Priority**
In the case of systems with multiple Wattpilots, charging priorities can be set (see [Priority](#)).
- **Fallback mode**
If there is no connection to the server, the Wattpilot limits the charging current back to the set value in fallback mode. This ensures that the infrastructure is not overloaded.
- **Overview**
Display of all Wattpilots in load balancing.

Name Change the name of the paired Wattpilot.

Brightness Set LED brightness values. By activating "**Switch off LEDs after 10 s in standby**", the LEDs on the device are switched off after 10 seconds in standby.

Time zone Set the time zone. Activating "**Automatic summer time changeover**" automatically sets the summer and winter time.

Access management

In the "**Access management**" menu, it is possible to set whether charging is started automatically or after confirmation. In addition, mode selection and current level selection can be set using the pushbutton on the device.

Authentication

- **Open:** The charging process is started automatically after connecting the cables.
- **Authentication required:** Charging will only start after confirming in the app or scanning the supplied ID chip.

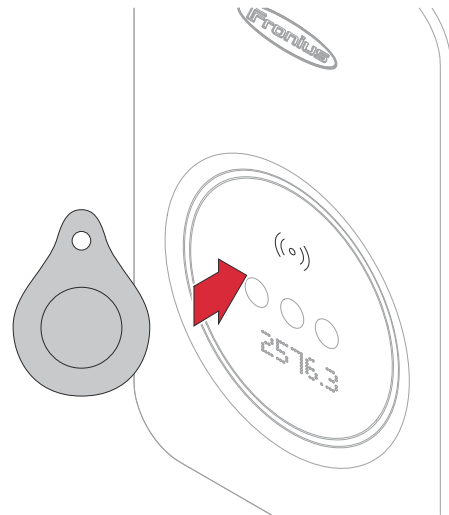

Scan the ID chip

- 1** Hold the ID chip in front of the card reader on the Wattpilot.
 - 2** Five LEDs light up green.
- ✓ *Charging starts.*

Lock mode selection

Set whether the pushbutton on the Wattpilot should be locked. Locking the pushbutton prevents accidental changing of the mode.

- **Always locked:** Changing the mode is only possible via the connected Fronius Solar.wattpilot app.
- **Locked when vehicle is connected:** Changing the mode by pressing the pushbutton is possible with the vehicle disconnected.
- **Never locked:** Standard setting.

Grounding test

Activation or deactivation of the grounding test. It is necessary to deactivate the grounding test in insulated grids in some countries (e.g., Norway).

ID chips

Up to 10 ID chips can be used. The ID chip is used for authentication and for recording user-specific charging amounts.

NOTE!

One ID chip can be taught in for several Fronius Wattpilot devices.

Learning an ID chip

- 1** Hold the **ID chip** in front of the card reader of the Wattpilot.
- 2** Click on "Teach in **ID chip**" in the app.

Renaming an ID chip

- 1** Tap the corresponding entry.
- 2** Enter the desired name and tap "Save".

NOTE!

The **ID chips** and the charging amount remain stored in the event of a reset.

Password

The password protects against unauthorized access to the Wattpilot.

Password guidelines

- At least 10 characters
- At least three of the following four strings: Upper case letters, lower case letters, numbers, special characters
- No umlauts (ä, ö, etc.)
- No paragraph sign (§)

Technician password

If the technician password is activated, it is required to access **Grid settings**, **Digital input** and **Load balancing**.

NOTE!

If the password has been forgotten, contact the support team.

Grid settings

Proceed as follows to call up the "**Grid settings**".

Technician password (if set)

- 1 Click on "**Grid settings**".
- 2 Enter the "**Technician password**".
- 3 Click "**OK**".

Choose country

Different charging conditions are allowed depending on the country. In this selection, all known default settings for the respective country are stored and can be selected directly.

Max. charging current

This setting is used to adjust the maximum charging current of the Wattpilot. Higher charging currents can no longer be selected.

NOTE!

PV optimization works best when the maximum charging current is set as high as the maximum allowed in the respective country. To start charging, the value must be higher than the minimum current in the vehicle settings.

General - Random maximum delay

Random charging start delay when using flexible electricity tariffs, charging timer or after a power failure. Random delay means that the grid is not overloaded when several Wattpilots start charging at the same time.

Phase unbalanced load

Activate and set the maximum asymmetry. Set the maximum asymmetry in accordance with the applicable regulations. Also see [Phase unbalanced load](#) on page 22.

Digital input

The digital input (DI_1) can be used with the Fronius Wattpilot Flex.

The digital input in the grid lead can be used to limit the charging current, e.g., for charging unlocking via a keylock switch, for the grid operator to connect to a ripple control receiver, or for Article 14(a) EnWG (Energy Industry Act). The digital input settings can be configured in the Solar.Wattpilot app (Settings > Digital input) and protected with the technician's password (Settings > Password > Protect digital input).

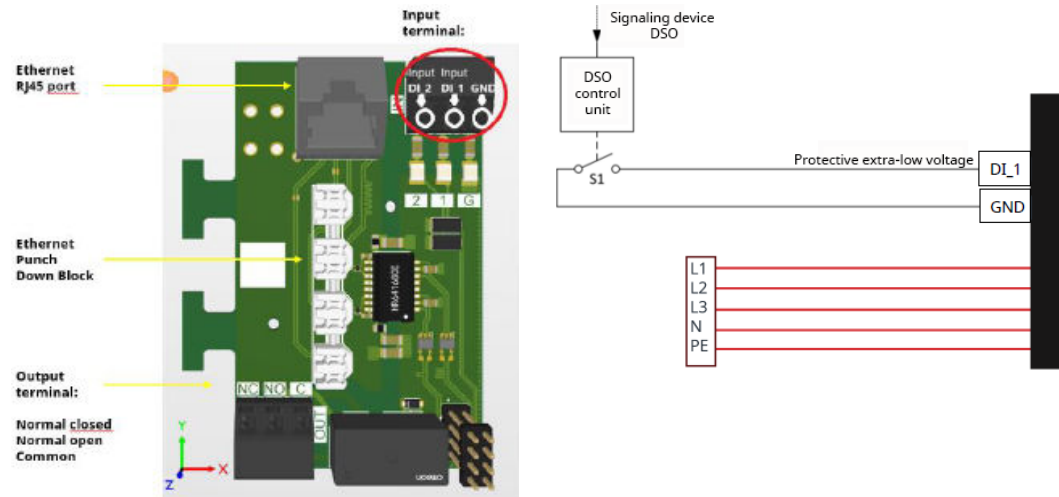

Internet

Connection

The following connection options can be configured in the "Internet" menu:

- WLAN
 - Configured networks and available networks are listed. More networks can be added.
 - For further information see chapter [Commissioning with app](#) on page 49.
- Ethernet
 - For further information see chapter [Data communication with inverter](#) on page 48.
- Hot spot password
 - Set the hot spot password.
 - For further information see chapter [Commissioning with app](#) on page 49.
 - Select whether the hotspot is always active or only if the WLAN connection is interrupted.
- Advanced settings
 - Activate or deactivate "Allow Internet connection". If "Allow Internet connection" is deactivated, functions such as the flexible electricity tariff, time synchronization or app connection to the Internet are not possible.
- OCPP
 - Configuration of the Open Charge Point Protocol (free charging point communication standard).
 - For further information see chapter [OCPP](#) on page 62.

OCPP

The charging point communication standard OCPP (Open Charge Point Protocol) is a universal communication protocol for charging infrastructures. It enables communication between the Watterpilot and a management system, via which, for example, load distribution of an infrastructure or billing can be carried out. It can be set up via a remote server provider or locally.

Activate OCPP

Activation or deactivation of OCPP.

Address

The address of the OCPP server must be provided by the provider and entered in the OCPP menu of the app.

Phase assignment

Implement settings for how the phases of the Watterpilot are assigned compared to a Smart Meter. This is necessary, for example, to ensure that load balancing functions correctly.

Status

The following status indicators are available:

- Not connected: OCPP is not activated and not connected to a management system.
- Started: OCPP is activated but there is no successful connection to the management system yet.
- Connected: OCPP is activated and there is a connection to the management system but it has not yet been accepted.
- Connected and accepted: OCPP is activated and there is a connection to the management system, the connection has been accepted.

Custom certificate

Possibility to enter a self-created certificate for OCPP.

Alternative ID

If a charging process is started without authentication with an ID chip (Access management > Authentication > Open), an alternative ID can be stored and sent to the backend.

Restart

After confirming the restart, the Wattpilot is restarted; the most recent settings remain saved.

Firmware update

The current firmware of the Wattpilot is loaded via the Internet. The "Internet" menu shows which firmware version is installed and whether an update is available.

Firmware update

- 1** Click on "Update available".
- 2** Select available version.
- 3** Click "Update firmware"
- 4** After a firmware update, check whether the Fronius Solar.wattpilot app also needs to be updated.

The Fronius Solar.wattpilot app can be updated via the respective platform (Google Play Store, App Store).

Beta

If a new beta version of the firmware is provided, you can install and test it in advance. Please send us your feedback on the beta versions.

Changing firmware

The old firmware remains stored on the Wattpilot after an update. In the event of an error, it is also possible to switch between the old and the new firmware version without an Internet connection.

Appendix

General

Residual current detection

The tripping characteristics of the residual current detection are as follows.

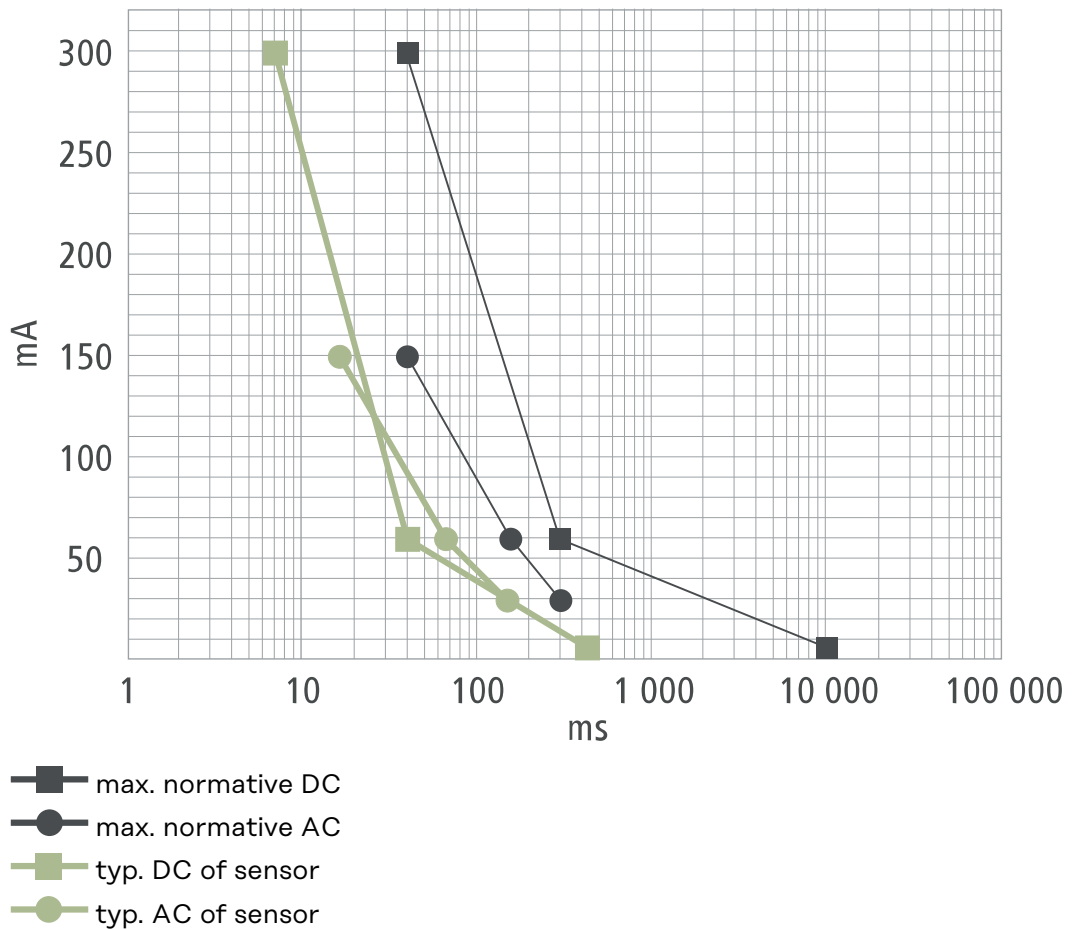

Safety functions

- RFID access control (ID chip, reset card)
- Theft-proof charging socket lock
- Cable protection (lock not included)
- Residual current device with DC detection, 20 mA_{AC}, 6 mA_{DC}
- Phase and voltage testing of the input voltage
- Auxiliary contact on the relays for checking the switching function
- Earthing detection (can be switched off, Norway mode)
- Current sensor, 3-phase
- Temperature monitoring

Technical data

Wattpi- lot Flex Home 11 C6

Fronius Wattpilot—technical data	Home 11 C6	
	1-phase	3-phase
Max. charging power	3.68 kW	11 kW
Mains supply types	TT / TN / IT	
Mains connection	5-pin screw terminal	
Nominal voltage	230/240 V	400/415 V
Nominal current (configurable)	6 - 16 A 1-phase or 3-phase	
Mains frequency	50 Hz	
Charging cable	6 m cable, type 2 charging plug	
Residual current protection device ¹	20 mA _{AC} , 6 mA _{DC} , integrated	
Supply line conductor cross-section	Mains cable top (interior), bottom, rear: 3 x 2.5 mm ² to 5 x 10 mm ² Cable diameter: 10 - 20 mm	
PV optimization ²	Dynamic PV surplus charging from 1.38 - 11 kW (at 230/400 V) (automatic 1-/3-phase switching)	
MID meter	Not integrated	
Measurement and calibration law compliance	No	
Interfaces	LAN (RJ45 or LSA) 10/100 Mbit/s WLAN 802.11 b/g/n 2 digital inputs Relay output prepared for ISO 15118	
Charging mode	Mode 3 as per IEC 61851-1 AC charging	
Authentication	RFID, Solar.wattpilot app	
Standby consumption	3.8 - 6.8 W (depends on settings)	
Communication protocol	OCPP 1.6 J	
Dynamic Load Balancing	Integrated (unlimited number of charging stations) ³	
Use	Indoor and outdoor ⁴	

¹An additional residual current circuit breaker and an automatic circuit breaker according to the applicable installation standards of the respective country must be connected upstream.

²Additional components are required for PV-optimized charging.

³An Internet connection is required for dynamic load balancing.

Fronius Wattpilot—technical data	Home 11 C6	
	1-phase	3-phase
Installation type	Suspended upright	
Protection class	IP66	
Standards	EN IEC 61851-1, EN 62196, ISO 15118 (prepared on the hardware side)	
Dimensions (height x width x depth)	325 x 195 x 105 mm	
Weight	4.1 kg	
Ambient temperature	-25 to +45 °C	
Humidity	5 - 95% (non-condensing)	
Height above sea level	0 - 2000 m	
Impact resistance	IK08	

**Wattpi-
lot Flex Home 22
C6**

Fronius Wattpilot—technical data	Home 22 C6	
	1-phase	3-phase
Max. charging power	7.36 kW	22 kW
Mains supply types	TT / TN / IT	
Mains connection	5-pin screw terminal	
Nominal voltage	230/240 V	400/415 V
Nominal current (configurable)	6 - 32 A 1-phase or 3-phase	
Mains frequency	50 Hz	
Charging cable	6 m cable, type 2 charging plug	
Residual current protection device ⁵	20 mA _{AC} , 6 mA _{DC} , integrated	
Supply line conductor cross-section	Mains cable top (interior), bottom, rear: 3 x 2.5 mm ² to 5 x 10 mm ² Cable diameter: 10 - 20 mm	
PV optimization ⁶	Dynamic PV surplus charging from 1.38 - 22 kW (at 230/400 V) (automatic 1-/3-phase switching)	
MID meter	Not integrated	
Measurement and calibration law compliance	No	

⁴When installed outdoors, the cable input must only be from below or from behind. In addition, the Wattpilot must not be exposed to direct sunlight.

⁵An additional residual current circuit breaker and an automatic circuit breaker according to the applicable installation standards of the respective country must be connected upstream.

⁶Additional components are required for PV-optimized charging.

Fronius Wattpilot—technical data	Home 22 C6	
	1-phase	3-phase
Interfaces	LAN (RJ45 or LSA) 10/100 Mbit/s WLAN 802.11 b/g/n 2 digital inputs Relay output prepared for ISO 15118	
Charging mode	Mode 3 as per IEC 61851-1 AC charging	
Authentication	RFID, Solar.wattpilot app	
Standby consumption	3.8 - 6.8 W (depends on settings)	
Communication protocol	OCPP 1.6 J	
Dynamic Load Balancing	Integrated (unlimited number of charging stations) ⁷	
Use	Indoor and outdoor ⁸	
Installation type	Suspended upright	
Protection class	IP66	
Standards	EN IEC 61851-1, EN 62196, ISO 15118 (prepared on the hardware side)	
Dimensions (height x width x depth)	325 x 195 x 105 mm	
Weight	5.4 kg	
Ambient temperature	-25 to +45 °C	
Humidity	5 - 95% (non-condensing)	
Height above sea level	0 - 2000 m	
Impact resistance	IK08	

Wattpilot Flex Pro 11 C6E

Fronius Wattpilot—technical data	Pro 11 C6E	
	1-phase	3-phase
Max. charging power	3.68 kW	11 kW
Mains supply types	TT / TN / IT	
Mains connection	5-pin screw terminal	
Nominal voltage	230/240 V	400/415 V
Nominal current (configurable)	6 - 16 A 1-phase or 3-phase	
Mains frequency	50 Hz	
Charging cable	6 m cable, type 2 charging plug	
Residual current protection device ⁹	20 mA _{AC} , 6 mA _{DC} , integrated	

⁷An Internet connection is required for dynamic load balancing.

⁸When installed outdoors, the cable input must only be from below or from behind. In addition, the Wattpilot must not be exposed to direct sunlight.

Fronius Wattpilot—technical data	Pro 11 C6E	
	1-phase	3-phase
Supply line conductor cross-section	Mains cable top (interior), bottom, rear: 3 x 2.5 mm ² to 5 x 10 mm ² Cable diameter: 10 - 20 mm	
PV optimization ¹⁰	Dynamic PV surplus charging from 1.38 - 11 kW (at 230/400 V) (automatic 1-/3-phase switching)	
MID meter	Integrated (accuracy class B)	
Measurement and calibration law compliance	Yes	
Interfaces	LAN (RJ45 or LSA) 10/100 Mbit/s WLAN 802.11 b/g/n 2 digital inputs Relay output prepared for ISO 15118	
Charging mode	Mode 3 as per IEC 61851-1 AC charging	
Authentication	RFID, Solar.wattpilot app	
Standby consumption	3.8 - 6.8 W (depends on settings)	
Communication protocol	OCPP 1.6 J	
Dynamic Load Balancing	Integrated (unlimited number of charging stations) ¹¹	
Use	Indoor and outdoor ¹²	
Installation type	Suspended upright	
Protection class	IP66	
Standards	EN IEC 61851-1, EN 62196, ISO 15118 (prepared on the hardware side)	
Dimensions (height x width x depth)	325 x 195 x 105 mm	
Weight	4.1 kg	
Ambient temperature	-25 to +45 °C	
Humidity	5 - 95% (non-condensing)	
Height above sea level	0 - 2000 m	
Impact resistance	IK08	

⁹ An additional residual current circuit breaker and an automatic circuit breaker according to the applicable installation standards of the respective country must be connected upstream.

¹⁰ Additional components are required for PV-optimized charging.

¹¹ An Internet connection is required for dynamic load balancing.

¹² When installed outdoors, the cable input must only be from below or from behind. In addition, the Wattpilot must not be exposed to direct sunlight.

**Wattpilot Flex
Pro 22 C6E**

Fronius Wattpilot—technical data	Pro 22 C6E	
	1-phase	3-phase
Max. charging power	7.36 kW	22 kW
Mains supply types	TT / TN / IT	
Mains connection	5-pin screw terminal	
Nominal voltage	230/240 V	400/415 V
Nominal current (configurable)	6 - 32 A 1-phase or 3-phase	
Mains frequency	50 Hz	
Charging cable	6 m cable, type 2 charging plug	
Residual current protection device ¹³	20 mA _{AC} , 6 mA _{DC} , integrated	
Supply line conductor cross-section	Mains cable top (interior), bottom, rear: 3 x 2.5 mm ² to 5 x 10 mm ² Cable diameter: 10 - 20 mm	
PV optimization ¹⁴	Dynamic PV surplus charging from 1.38 - 22 kW (at 230/400 V) (automatic 1-/3-phase switching)	
MID meter	Integrated (accuracy class B)	
Measurement and calibration law compliance	Yes	
Interfaces	LAN (RJ45 or LSA) 10/100 Mbit/s WLAN 802.11 b/g/n 2 digital inputs Relay output prepared for ISO 15118	
Charging mode	Mode 3 as per IEC 61851-1 AC charging	
Authentication	RFID, Solar.wattpilot app	
Standby consumption	3.8 - 6.8 W (depends on settings)	
Communication protocol	OCPP 1.6 J	
Dynamic Load Balancing	Integrated (unlimited number of charging stations) ¹⁵	
Use	Indoor and outdoor ¹⁶	

¹³ An additional residual current circuit breaker and an automatic circuit breaker according to the applicable installation standards of the respective country must be connected upstream.

¹⁴ Additional components are required for PV-optimized charging.

¹⁵ An Internet connection is required for dynamic load balancing.

¹⁶ When installed outdoors, the cable input must only be from below or from behind. In addition, the Wattpilot must not be exposed to direct sunlight.

Fronius Wattpilot—technical data	Pro 22 C6E	
	1-phase	3-phase
Installation type	Suspended upright	
Protection class	IP66	
Standards	EN IEC 61851-1, EN 62196, ISO 15118 (prepared on the hardware side)	
Dimensions (height x width x depth)	325 x 195 x 105 mm	
Weight	5.4 kg	
Ambient temperature	-25 to +45 °C	
Humidity	5 - 95% (non-condensing)	
Height above sea level	0 - 2000 m	
Impact resistance	IK08	

Status codes and remedy

Status codes

Due to phase, voltage, and switching function checks of the Fronius Wattpilot, a charging operation may be rejected.

The status codes are displayed via the LED status indicator (see [LED status indicators](#) on page 16) directly on the Wattpilot and in the app under "Status".

1—Fault current detected (LEDs light up pink, the LEDs at the top flash red)

Cause: The residual current device has detected an error.

Remedy: The charging equipment in the vehicle may be defective. Have the charging equipment checked by a specialist.

Remedy: Disconnect and reconnect the charging cable.

3—At least one phase of the power supply is missing (the LEDs light up blue, the LEDs at the top flash red)

Cause: The device is only being supplied with 2 phases.

Remedy: Make sure that phase 2 and phase 3 are connected correctly. Option: a supply via phase 1 only is possible.

8—Grounding fault detected (the LEDs light up green and yellow, the LEDs at the top flash red)

Cause: Grounding fault detected.

Remedy: Check that the connection is properly grounded.

10—Relay fault detected

Cause: The relay has not switched.

Remedy: Disconnect the power supply to the device for 5 seconds.

11—Backup power mode detected

Cause: 53 Hz mains current detected.

Remedy: Observe the instructions in the Operating Instructions.

100—Internal communication error (all LEDs flash red)

Cause: Device is not sending data.

Remedy: Disconnect and reconnect device.

Remedy: Perform a firmware update.

Remedy: Return device.

101—Temperature too high (the LEDs light up yellow, the LEDs at the top flash red)

Cause: Continuous load.

Remedy: Disconnect device and allow to cool down.

Cause: Incorrectly installed cables.

Remedy: Disconnect device and allow to cool down.

105—No data available on the flexible electricity tariff (first or second LED—Eco Mode or Next Trip Mode—flashes red)

Cause: Flexible electricity tariff cannot be called up.

Remedy: Check WLAN and Internet connection.

Remedy: Wait until the server is available again.

109—No connection to the inverter (first or second LED—Eco Mode or Next Trip Mode—flashes red)

- Cause: The connection to the inverter cannot be established.
- Remedy: Check the network settings.
- Remedy: Check the settings of the inverter.
- Remedy: Make sure that the Fronius Solar API is activated on the inverter.

114—For Eco Mode, PV surplus or flexible electricity tariff must be activated (Eco Mode LED flashes orange)

- Cause: Eco Mode is selected and the "Use PV surplus" and "Use Lumina Strom / aWattar" settings are disabled.
- Remedy: Activate the setting "Use PV surplus" and/or "Use Lumina Strom / aWattar".
- Remedy: Change the mode.
- Cause: "Use Lumina Strom / aWattar" is enabled and there is no data connection to the Internet. Cached price data is still available.
- Remedy: Check the network settings.

115—The set amount of energy cannot be reached in the specified time (second LED—Next Trip Mode—flashes orange)

- Cause: The specified time is not sufficient for the desired amount of energy.
- Remedy: Extend the specified time for charging.
- Remedy: Reduce the desired amount of energy.

116—Update of flexible electricity tariffs failed (first or second LED—Eco Mode or Next Trip Mode—flashes orange)

- Cause: The connection cannot be established.
- Remedy: Check the network settings.

The charging operation cannot be started, but all LEDs show the ready color (default blue).

- Cause: The vehicle is not being detected.
- Remedy: Check vehicle cable and fit of charging plugs

No LEDs light up after plugging in.

- Cause: No power on the junction box.
- Remedy: Check the overload fuse of the connection.
- Cause: The brightness of the LEDs has been set to 0.
- Remedy: Increase the brightness of the LEDs in the Fronius Solar.wattpilot app.
- Cause: "Switch off LEDs after 10 s in standby" has been enabled.
- Remedy: Deactivate "Switch off LEDs after 10 s in standby" or press the push button on the Wattpilot.
-

Terms and conditions of warranty and disposal

Fronius manufacturer's warranty

Detailed warranty conditions specific to your country can be found at www.fronius.com/solar/garantie.

Disposal

Waste electrical and electronic equipment must be collected separately and recycled in an environmentally sound manner in accordance with the European Directive and national law. Used equipment must be returned to the distributor or through a local authorized collection and disposal system. Proper disposal of the used device promotes sustainable recycling of resources and prevents negative effects on health and the environment.

Packaging materials

- Collect separately
- Observe local regulations
- Crush cardboard boxes



fronius.com/en/solar-energy/installers-partners/products-solutions/monitoring-digital-tools

**MONITORING &
DIGITAL TOOLS**

Fronius International GmbH

Froniusstraße 1
4643 Pettenbach
Austria
contact@fronius.com
www.fronius.com

At www.fronius.com/contact you will find the contact details of all Fronius subsidiaries and Sales & Service Partners.