



# Air Cooling Energy Storage System

**AELIO-P50B200 / AELIO-P60B200**

## User Manual

Version 1.0

[www.solaxpower.com](http://www.solaxpower.com)



©Manhattan (Shanghai) Co., Ltd.  
<http://kb.solaxpower.com/>



# STATEMENT

---

## Copyright

Copyright © SolaX Power Network Technology (Zhejiang) Co., Ltd. All rights reserved.

No part of this manual may be reproduced, transmitted, transcribed, stored in a retrieval system, or translated into any language or computer language, in any form or by any means without the prior written permission of SolaX Power Network Technology (Zhejiang) Co., Ltd.

## Trademarks



SOLA<sup>POWER</sup> and other symbol or design (brand name, logo) that distinguishes the products or services offered by SolaX has been trademark protected. Any unauthorized use of the above stated trademark may infringe the trademark right.

## Notice

Please note that certain products, features, and services mentioned in this document may not be within the scope of your purchase or usage. Unless otherwise specified in the contract, the contents, information, and recommendations presented in this document are provided "as is" by SolaX. We do not provide any warranties, guarantees, or representations, whether express or implied.

The content of the documents is reviewed and updated as needed. However, occasional discrepancies may occur. SolaX retains the right to make improvements or changes in the product(s) and the program(s) described in this manual at any time without prior notice.

The images included in this document are solely for illustrative purposes and may differ based on the specific product models.

For more detailed information, kindly visit the website of SolaX Power Network Technology (Zhejiang) Co., Ltd. at [www.solaxpower.com](http://www.solaxpower.com).

SolaX retains all rights for the final explanation.

# About This Manual

---

## Scope of Validity

This manual is an integral part of AELIO-P50B200 and AELIO-P60B200. It describes the transportation, storage, installation, electrical connection, commissioning, maintenance and troubleshooting of the product. Please read it carefully before operating.

AELIO-P50B200 and AELIO-P60B200 system includes a X3-AELIO series inverter and a AELIO-B200 battery cabinet.

X3-AELIO series inverter model list:

Model	X3-AELIO-50K	X3-AELIO-60K
-------	--------------	--------------

Battery cabinet model list:

Model	AELIO-B200
-------	------------

### Model description

# AELIO-P50B200



No.	Definition	Description
1	Product name	AELIO: Refer to the name of hybrid energy storage system.
2	Power	P50: Indicate that the rate power of the inverter is 50 kW.
3	Battery capacity	B200: Indicate that the battery capacity is 200 kWh.





## Target Group

The installation, maintenance and grid connection setting can only be performed by qualified personnel who

- Are licensed and/or satisfy state and local jurisdiction regulations.
- Have good knowledge of this manual and other related documents.
- A medium-voltage operator is required to obtain any Certifications for High-voltage Electrician.

## Conventions

The symbols that may be found in this manual are defined as follows.

Symbol	Description
 <b>DANGER</b>	Indicates a hazardous situation which, if not avoided, will result in death or serious injury.
 <b>WARNING</b>	Indicates a hazardous situation which, if not avoided, could result in death or serious injury.
 <b>CAUTION!</b>	Indicates a hazardous situation which, if not avoided, could result in minor or moderate injury.
 <b>NOTICE!</b>	Provides tips for the optimal operation of the product.

## Change History

### Version 01 (2024-12-30)

Updated safety regulation in "1 Safety", "3 Transportation and Storage" and "4 Preparation before Installation".

Updated AC side technical data in "13 Technical Data".

### Version 00 (2024-09-09)

Initial release

# Table of Contents

---

- 1 Safety ..... 1
  - 1.1 General Safety ..... 1
  - 1.2 Device Safety ..... 2
    - 1.2.1 Cabinet Safety ..... 2
    - 1.2.2 Battery Safety ..... 3
    - 1.2.3 Inverter Safety ..... 5
    - 1.2.4 Utility Grid Safety ..... 7
  - 1.3 Electrical Safety ..... 7
- 2 Product Overview ..... 10
  - 2.1 System Overview ..... 10
  - 2.2 Product Introduction ..... 12
  - 2.3 Appearance and Dimension ..... 12
  - 2.4 Parts Description ..... 13
  - 2.5 Indicator ..... 24
  - 2.6 Symbols ..... 27
  - 2.7 Working Mode ..... 28
    - 2.7.1 Self-use Mode (Priority: Loads > Battery > Grid) ..... 28
    - 2.7.2 Feed-in Priority (Priority: Loads > Grid > Battery) ..... 30
    - 2.7.3 Backup Mode (Priority: Loads > Battery > Grid) ..... 31
    - 2.7.4 Peak Shaving Mode ..... 33
    - 2.7.5 TOU Mode ..... 34
    - 2.7.6 EPS Mode (Priority: Loads > Battery) ..... 35
    - 2.7.7 Manual Mode ..... 36
    - 2.7.8 Export Control Function ..... 36
  - 2.8 Application Schemes ..... 38
  - 2.9 Operating Principle ..... 40
- 3 Transportation and Storage ..... 41
  - 3.9.1 Battery Cabinet Transportation ..... 41
  - 3.9.2 Inverter Transportation ..... 43
  - 3.1 Storage ..... 44
    - 3.1.1 Cabinet Storage ..... 44
    - 3.1.2 Inverter Storage ..... 45
- 4 Preparation before Installation ..... 46
  - 4.1 Installation Site Selection ..... 46

4.1.1	Installation Foundation Requirements .....	48
4.1.2	Clearance Requirement .....	53
4.2	Tools Requirement .....	55
4.3	Additionally Required Materials .....	57
<b>5</b>	<b>Unpacking and Inspection .....</b>	<b>58</b>
5.1	Battery Cabinet Unpacking .....	58
5.1.1	Unpacking .....	58
5.1.2	Packing List .....	59
5.2	Inverter Unpacking .....	61
5.2.1	Unpacking .....	61
5.2.2	Packing List .....	62
<b>6</b>	<b>Mechanical Installation .....</b>	<b>64</b>
6.1	Battery Cabinet Installation Dimensions .....	65
6.2	Battery Cabinet Handling .....	67
6.2.1	Hoisting .....	67
6.2.2	Forklift .....	70
6.3	Installation Procedure for Angle Support and Cover .....	71
6.4	Antenna Installation .....	73
6.5	Inverter Installation .....	75
6.5.1	Inverter Installation Dimensions .....	76
6.5.2	Installation Procedures .....	77
<b>7</b>	<b>Electrical Connection .....</b>	<b>81</b>
7.1	Cabinet Grounding Connection .....	82
7.2	Inverter Electrical Connection .....	85
7.2.1	Terminals of Inverter .....	86
7.2.2	Inverter Grounding Connection .....	87
7.2.3	AC Connection .....	89
7.2.4	PV Connection .....	94
7.2.5	Battery Power Cable Connection .....	99
7.2.6	COM 1 Communication Connection .....	103
7.2.7	COM 2 Communication Connection .....	113
7.3	EPS Connection .....	121
7.4	Grid Connection .....	128
7.5	Fireproof Mud .....	136
7.6	Installation Procedure for Cable Cover .....	137
<b>8</b>	<b>System Commissioning .....</b>	<b>139</b>
8.1	Checking before Power-on .....	139

8.2	Power ON .....	140
8.3	Checking after Power-on .....	145
<b>9</b>	<b>System Configuration .....</b>	<b>146</b>
9.1	Operation on Inverter LCD .....	146
9.1.1	Introduction of Control Panel .....	146
9.1.2	Introduction of Menu Interface .....	147
9.1.3	Setting .....	147
9.2	Inverter Screen Cover Installation .....	149
9.3	Operation on Cabinet Screen .....	151
9.3.1	Logging in .....	151
9.3.2	Adding Inverter .....	152
9.3.3	Pairing Inverter and Cabinet .....	154
<b>10</b>	<b>SolaXCloud App .....</b>	<b>156</b>
10.1	Introduction of SolaXCloud .....	156
10.2	Operation Guide on SolaXCloud App .....	156
10.2.1	Downloading and Installing App .....	156
10.2.2	Operation on the SolaXCloud App .....	157
<b>11</b>	<b>Troubleshooting and Maintenance .....</b>	<b>158</b>
11.1	Power Off .....	158
11.2	Operation of Lockable DC Switch (for Australia Version Only) .....	164
11.3	Troubleshooting .....	166
11.3.1	Battery Cabinet Troubleshooting .....	166
11.3.2	Inverter Troubleshooting .....	171
11.4	Maintenance .....	179
11.4.1	Disassembly and Clean of Air Conditioner Filter .....	182
<b>12</b>	<b>Decommissioning .....</b>	<b>184</b>
12.1	Disposing of the Wasted and Damaged Battery Pack .....	184
12.2	Disposing of the Wasted and Damaged Inverter .....	184
<b>13</b>	<b>Technical Data .....</b>	<b>185</b>
<b>14</b>	<b>Appendix .....</b>	<b>187</b>
14.1	Requirements for OT/DT/TO Terminal .....	187
14.2	How to Repaint the Cabinet .....	189
14.2.1	Light Scratches & Small Areas of Stubborn Stains .....	189
14.2.2	Deep Scratches and Large Areas of Stubborn Stains .....	191
14.2.3	Logo & Pattern damaged, Dents or Dings .....	194
14.3	Micro-grid Application .....	195
14.3.1	Introduction of Micro-grid Application .....	195

14.3.2	Wiring Connection Diagram.....	195
14.3.3	Working Modes.....	196
14.3.4	Cable Connection (Hybrid inverter).....	198
14.3.5	Cable Connection (On-grid Inverter).....	198
14.3.6	Cable Connection (Meter).....	198
14.4	CT/Meter Connection Scenarios .....	201
14.4.1	Connection of CT.....	201
14.4.2	Connection of Direct-connected Meter .....	204
14.4.3	Connection of CT-connected Meter .....	207
14.4.4	Connection of Two Meters .....	210

# 1 Safety

---

## 1.1 General Safety

Before transporting, storing, installing, operating, using and/or maintaining the device, please carefully read and understand the document, and strictly follow the instructions and safety precautions given herein, as well as symbols affixed on the device. The safety instructions herein are only supplements to local laws and regulations.

The operator should not only abide by all safety precautions provided in the document, including but not limited to the "Danger" sign, "Warning" sign, "Caution" sign, and "Notice" sign, but also comply with relevant international, national and local laws, regulations, standards, guidelines and industry rules in the process of transportation, storage, installation, operation, and maintenance. SolaX will not assume any responsibilities for the loss caused by improper operation, or violation of safety standards for design, production and equipment suitability.

SolaX will not be liable for maintenance for possible device failure, device malfunction, or parts damage, nor will the company assume any liability to pay compensation for the possible physical and property damage resulting from the installation environment that does not meet the design requirements.

The device is well designed and tested to meet all applicable state and international safety standards. However, like all electrical and electronic equipment, safety precautions must be observed and followed during the installation of the device to reduce the risk of personal injury and to ensure a safe installation.

SolaX will not assume any responsibilities if any of the following circumstances occur, including but not limited to:

- Device damage due to force majeure, such as earthquake, flooding, thunderstorm, lighting, fire hazard, volcanic eruption, war, typhoon, tornado, etc.
- Device damage due to human cause.
- Device used or operated against local policy or regulations.
- Failure to follow the operation instructions and safety precautions on the product and in this document.
- Installation and use under improper environment or electrical condition.
- Unauthorized modifications to the product or software.
- Device damage caused during transportation by the customer or the third party.
- Storage conditions that do not meet the requirements specified in this document
- Use of incompatible inverters or devices.
- Installation and commissioning operated by unauthorized personnel who are not licensed and /or satisfy state and local jurisdiction regulations.

## 1.2 Device Safety

To prevent personal injury or property damage from improper operation, please carefully read the following installation precautions before installation.

### 1.2.1 Cabinet Safety

#### DANGER!

- According to the local laws and regulations related to high-altitude work, operators must wear PPE, e.g., a helmet, safety belt, or waist harness, when they work at heights, while the other end of the harness must connect to a secure structure to prevent fall incidents.

#### WARNING!

- Please prepare tools that meet the requirements before installation, and check the number of tools after installation, to avoid leaving them inside the equipment.
- Please ensure that the cabinet has been thoroughly secured before operating it. Otherwise, it may cause personal injury or equipment damage due to tilting or collapsing the cabinet.
- Please ensure that the cabinet's vents and cooling system are working properly when it is running. If the vents are blocked, it will lead to overheating, and even equipment damage or fire hazard.
- Please ensure that the cabinet's vents and cooling system are kept away from heat sources.
- Do not drill holes in the device to avoid equipment failure.
- If the circumstances that may cause personal injury or equipment failure occur, such as, fluid flowing into the equipment, stop operation and power off immediately. Otherwise, it may cause a short circuit or damage.
- Do not open the cabinet doors on a rainy or high humid day ( $\geq 80\%$  humidity). If the doors have to be opened on such days, please take proper protective measures.

#### CAUTION!

- Do not use a straight ladder. When electrical work is involved, a wooden ladder or an insulated ladder shall be used.
- The equipment shall not be used to provide a backup power source in the following circumstances:
  - a. Equipment related to life;
  - b. Sensitive precision instruments;
  - c. Home appliances will be faulty in the case of a power failure during operation.

#### NOTICE!

- The signs and messages on the labels and nameplates attached to the device need to be visible and clear.

## 1.2.2 Battery Safety

### DANGER!

- Do not connect the positive and negative poles of a battery together. Otherwise, it may be short-circuited. This will result in an excessive flow of current and large quantities of energy for a short time, and then will cause battery leakage, smoke, the emission of flammable gases, thermal runaway, fire, or even an explosion. Therefore, the battery must be powered off before maintenance.
- If a battery is overheated, it will cause leakage, smoke, release of flammable gases, thermal runaway, fire, or even an explosion. Therefore, please ensure that the installation site shall be well ventilated and kept away from high temperatures.
- Do not dismantle, change, shake, drop, crush, impact, cut, penetrate with a sharp object, or any other ways to damage the battery. Otherwise, it may cause leakage, smoke, emission of flammable gases, thermal runaway, fire, or even an explosion.
- Do not mix different types or makes of the battery. Otherwise, it may cause leakage or rupture, resulting in personal injury or property damage.
- The battery electrolyte is toxic and volatile. Never get in contact with the leaked liquids or inhale gases in the case of the battery leakage or odor, and contact professionals immediately. The professional must wear PPE (including but not limited to safety glasses, safety gloves, gas masks, and protective clothing) before powering off the device, and then contact our company at once after removing the damaged battery.
- Normally, the battery will not release any gases. However, in the following situations: burnt, needle-pricked, squeezed, struck by lightning, overcharged, or subject to other adverse conditions that may cause battery thermal runaway, the battery may be damaged or an abnormal chemical reaction may occur inside the battery, resulting in electrolyte leakage or production of gases. If the battery needs to exhaust flammable gas, safe emission measures must be taken to prevent fire and device corrosion.
- Do not use damaged batteries, and ensure that the installation site must be well ventilated.

### WARNING!

- Please read the document carefully before installation, operation and maintenance.
- Must arrange fire-fighting equipment in advance according to the local laws, regulations, and standards while installing and commissioning the device.
- Please check that there is no damage to the outer packaging before and after unpacking, and in the process of storage and transportation. The battery shall be correctly placed or stacked in accordance with the requirements stipulated on the labels to prevent damaging or scrapping the battery resulting from crushing or falling.

 **WARNING!**

- Must tighten screws securing cables and on the copper bars according to the torque information specified in the document, and check whether they are tightened periodically. For instance, whether there is any rust, corrosion, or any other foreign object on it, and then clean it up if any. Because the loose screw connections may result in excessive voltage drops and large currents, leading to generating a lot of heat and burning the battery.
- The battery should be charged in time after discharge, to prevent battery damage due to overdischarge. If a battery pack is stored for a long time, please periodically recharge it to protect it from damage according to the storage requirements specified in the document.
- Please charge the battery within the specific temperature range because the low temperature may result in a short circuit. Hence, do not charge it when the temperature is below the low limit of the operating temperature.
- Do not use the battery when you find a bulge, or dents on the battery housing, and contact the installer or professional maintenance personnel to dismantle and replace it. The damaged battery must be kept away from other devices and flammable and explosive articles, and do not contact it except for professionals.
- Before operation, ensure that there are no irritating or burning smells around the battery.
- Do not weld or grind near a battery. Because electric sparks or arcs may cause fires.
- Do not step, lead, stand, or set on the battery.

**NOTICE!**

**Transportation requirements for battery:**

- Relevant qualifications for the transport of dangerous goods must be obtained by the forwarding agent engaged in such businesses, and they must strictly abide by the local regulations for the transport of dangerous goods.
- Please check the battery before transportation. If a battery leaks, smells, or is damaged, do refuse to transport it.
- Please handle gently in the process of loading and unloading, transportation, and moving a battery to prevent bumping, and take effective moisture-proof measures to prevent personal injuries and battery damage.
- Unless otherwise specified, do not transport the batteries, which are classified as dangerous goods, together with food, medicine, or other additives on the same means of transport.

**If the battery leaks electrolyte or any other chemical materials, the electrolyte leakage can lead to toxic gases. Therefore, do not contact with them at all times. In case of accidentally coming into contact with them, please do as follows:**

- In case of inhalation: Leave the contaminated area immediately, and seek medical attention at once;
- In case of contact with eyes: Rinse eyes with running water for at least 15 minutes, and seek medical attention;
- In case of contact with skin: Wash the contact area thoroughly with soap, and seek medical attention;
- In case of ingestion: Induce vomiting, and seek medical attention.

**NOTICE!**

**If a fire breaks out where the battery is installed, please do as follows:**

- In case a battery is charging when the fire breaks out, provided it is safe to do so, press the emergency stop button and unplug the power cable;
- In case a battery is not on fire yet, use a water-based fire extinguisher or a carbon dioxide extinguisher to extinguish the fire;
- In case a battery catches fire, do not try to put it out, and evacuate immediately;
- A battery may catch fire when it is heated above 150°F/60°C. If the battery catches fire, please evacuate immediately since it will generate noxious and poisonous gases.

**Recovery of damaged or wasted battery:**

- Dispose of the damaged or wasted batteries according to local laws and regulations instead of placing them in the household trash or curbside recycling bins. Otherwise, it may cause environmental pollution or explosions.
- Ensure that the damaged or wasted batteries are not exposed to the following situations: high temperatures, high humidity, direct sunlight, or corrosive environments.
- Contact a battery recycling company to scrap the battery, which leaks electrolytes, or is damaged or expired.
- Please take protective steps to prevent battery short circuits before moving batteries.
- Please keep away from flammable material storage areas, residential areas, and other population centers when transporting and storing the damaged battery.

### 1.2.3 Inverter Safety

#### PV safety



- Exposure to sunlight can result in the generation of high DC voltage by PV modules, which can lead to electric shock causing severe injuries or even death.
- Never touch the positive or negative poles of the PV connecting device, and avoid touching both poles simultaneously.
- Do not ground the positive or negative poles of the PV modules.
- Only qualified personnel can perform the wiring of the PV modules.

 **WARNING!**

- Overvoltage protection with surge arresters should be provided when the PV system is installed. The grid connected inverter is fitted with SPDs on both PV input side and MAINS side.
- Please consult professionals before installing SPDs.
- Make sure that the input DC voltage does not exceed the maximum DC input voltage specified for the inverter. Overvoltage can cause irreversible damage to the inverter, and such damage is not covered by the warranty.
- PV modules should have an IEC61730 class A rating.

**Inverter Safety**

 **DANGER!**

- Only operate the inverter if it is in a technically faultless condition. Operating a faulty inverter may lead to electric shock or fire.
- Do not attempt to open the enclosure without authorization from SolaX. Unauthorized opening of the enclosure will void the warranty and can result in lethal danger or serious injury due to electric shock.
- Make sure that the inverter is reliably grounded before any operation to prevent the risk of electric shock causing lethal danger or serious injury.
- Only qualified personnel can perform the installation, wiring, maintenance of the inverter by following this document and the related regulations.

 **WARNING!**

- Operators must wear PPE while installation and maintenance of the device.
- During operation, avoid touching any parts of the inverter other than the DC switch and LCD panel.
- Never connect or disconnect the AC and DC connector while the inverter is running.
- Prior to conducting any maintenance, turn off the AC and DC power and disconnect them from the inverter. Wait for 15 minutes to fully discharge the energy.
- Avoid touching the inverter while it is running, as it becomes hot during operation and may cause personal injuries.

 **CAUTION!**

- Make sure that children are supervised to prevent them from playing with the inverter.
- Pay attention to the weight of the inverter and handle it properly to avoid personal injuries.

**NOTICE!**

- The inverter has an integrated Residual Current Monitoring Unit (RCMU). If an external Residual Current Device (RCD) is required by local regulations, verify the type of RCD required. It is recommended to use a Type-A RCD with a rating of 300 mA unless a lower value is required by the specific local electric codes. When required by local regulations, the use of an RCD type B is permitted.
- Keep all product labels and the nameplate on the inverter clearly visible and well-maintained.

### 1.2.4 Utility Grid Safety

**NOTICE!**

- Only connect the inverter to the grid with the permission of the local utility grid company.

## 1.3 Electrical Safety

** DANGER!**

- Please make sure that the unit is free from any damage before the electrical connection.
- Do not modify, change, or dismantle the device, do not change the power-on and power-off sequences and the installation procedure written in the document, and please properly and correctly operate it.
- Do not power on the device during installation. Otherwise, it may cause a fire, personal injury, or device damage.
- Must remove earrings, rings, bracelets, watches, and any other metal jewelry before operation, to avoid electrical shock, burns, or even death.
- During operation, special insulated tools must be used to avoid electric shock or short circuit failure. The insulated tools' voltage ratings must exceed the system voltage ratings. Please refer to "12 Technical Data" for system information.

** WARNING!**

- Please wear PPE, such as, protective clothing, insulating shoes, goggles, safety helmets, insulating gloves, etc., when conducting electrical wiring.
- Do not touch the power supply equipment directly, or through conductors or damp objects.
- Do not touch the parts of the equipment of which warning signs are attached, to avoid personal injury or device damage.

 CAUTION!

- Do not power on the device until it has been installed and confirmed by professionals.
- In the event of a fire, evacuate immediately and call the local fire services.

NOTICE!

- Please operate according to the safety code for power station.
- Before installation, it is necessary to set up temporary safety fences or warning lines and hang warning signs in the operation area, to prohibit non-staff from entering here.
- Please make sure that the equipment and its associated switches are off before connecting and disconnecting power cables.
- Please check whether the protective housing and insulating sleeve for an electrical component have been installed correctly after finishing installation, to avoid electric shock.
- Must turn off the output switch of the power supply equipment when maintaining its electrical terminal device and power distribution device.
- If the device is required to be powered off during troubleshooting and diagnosis, please do as the following procedure: power off > electricity testing > connecting grounding cable > hanging warning signs and setting up guardrails.
- Must hang up "Do Not Switch On" warning signs on the relevant switches or circuit breakers before completing maintenance, to prevent power connection. Do not switch on before the fault is solved.
- Do not use water, alcohol, oil, or other solvents when cleaning electrical components inside and outside the device.

NOTICE!

**Grounding Requirements:**

- The device's grounding impedance shall meet the requirements of local electrical safety standards.
- The equipment shall be permanently connected to a grounding wire within the building's electrical system. Please check whether the device is reliably grounded before operation. The grounding cable should be removed last while dismantling and maintaining the device.
- Do not start the device if it is not fitted with a grounding conductor.
- All acts against the grounding conductor are prohibited.
- If the device is equipped with a three-pronged socket, make sure that the ground prong is reliably grounded.
- For the device that may generate large contact currents, please make sure that the grounding terminal on the housing has been grounded before powering on, to avoid electric shock.

**NOTICE!****Cable Requirements:**

- When deciding the wire diameter, and connecting or wiring cables, follow the local laws, regulations, and codes to ensure safety.
  - When external conditions (e.g., placement method, ambient temperature, etc.) change, the cable type must be verified according to IEC-60364-5-52 or local laws, regulations and standards. For instance, whether the cable's current-carrying capacity meets the requirements.
  - Before connecting power cables, please make sure that the cable labels are correctly labelled and the cable terminals are well insulated.
  - Do not loop and twist cables while conducting electrical wiring. If the length of the power cable is not enough, please replace it instead of joining or welding. Ensure that all the cables of the correct type and size are fully connected and well insulated, and the edges of cable slots and crossing holes are smooth.
- 
- It is recommended to bundle similar cables with cable ties, to ensure that the inside of the device is neat and tidy and to avoid cable jacket damage.
  - Please use fireproof mud to seal the threading openings immediately after finishing wiring, to avoid the entry of water vapour or small animals.
  - Cables should be kept away from heaters or other heat sources, because a high temperature environment may result in aging and damage to cable insulation.

# 2 Product Overview

## 2.1 System Overview

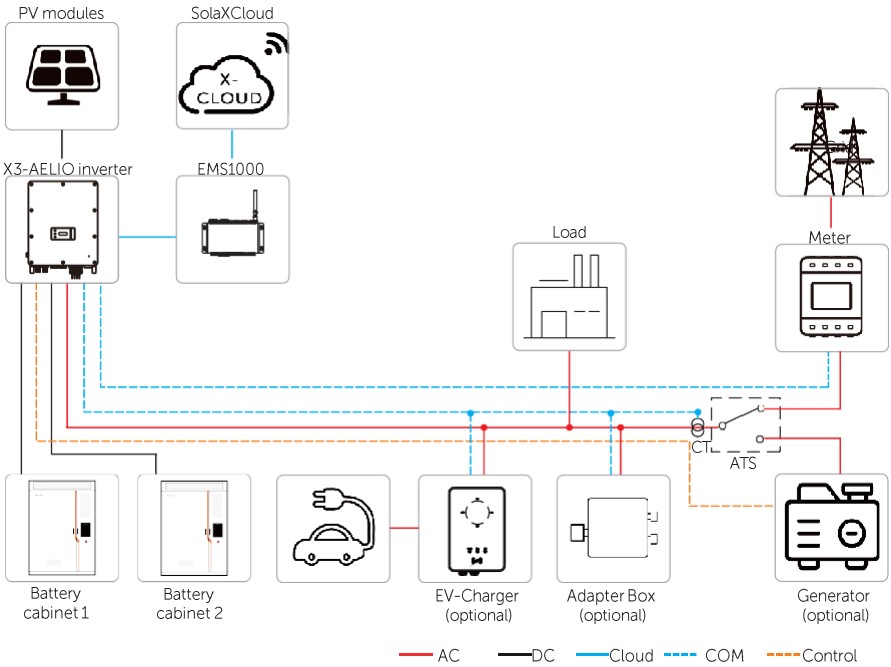

Figure 2-1 System overview diagram

Table 2-1 System item description

Item	Description
X3-AELIO series inverter	The X3-AELIO series inverter manages battery and system energy.
PV modules	PV modules work in MPPT mode. The maximum number of PV MPP tracker is five for 50 kW inverter and six for 60 kW inverter.
Battery cabinet	The AELIO-B200 cabinet integrates high-performance 280Ah LFP battery cells, high voltage box, fire suppression system, air cooling system and optional EMS1000 and screen.
CT/Meter	The CT/meter is used by the inverter for import / export or consumption readings, and manages the battery charge / discharge accordingly for smart energy management applications.
Adapter Box (optional)	With SolaX Adapter Box, you can connect the smart heat pump to the energy storage systems, realizing the control of the heat pump through inverter.
EV-Charger (optional)	The inverter can communicate with SolaX EV-Charger to form an intelligent photovoltaic, storage and EV charging energy system, thus maximizing the utilization of photovoltaic energy.
Generator (optional)	SolaX PV-Genset solution ensures optimum interaction between the photovoltaics and diesel generator, which saves fuel, lowers energy costs and ensures a stable and reliable power supply.
Grid	400 V / 230 V and 380 / 220 V grid are supported. Power grid TT, TN-C, TN-C-S can be supported.
SolaXCloud	SolaXCloud is an intelligent, multifunctional monitoring platform that can be accessed either remotely or through a hard wired connection. With the SolaXCloud, the operators and installers can always view key and up-to-date data. There are two SolaXCloud platforms. Commercial platform can be connected through EMS1000 connection.

## 2.2 Product Introduction

The product "AELIO-P50B200" and "AELIO-P60B200", a smart outdoor energy storage system with easy installation and convenient expansion, integrates high-capacity battery packs, a high-performance inverter, smart EMS, high-voltage box, and fire extinguishing system in a cabinet based on the design concept of "ALL-IN-ONE". The industrial and commercial scenarios are designed to be broadly applicable.

The entire system consists of X3-AELIO series inverter, cabinet, battery packs, high-voltage box, distribution box, IO module, EMS, switch, and UPS.

## 2.3 Appearance and Dimension

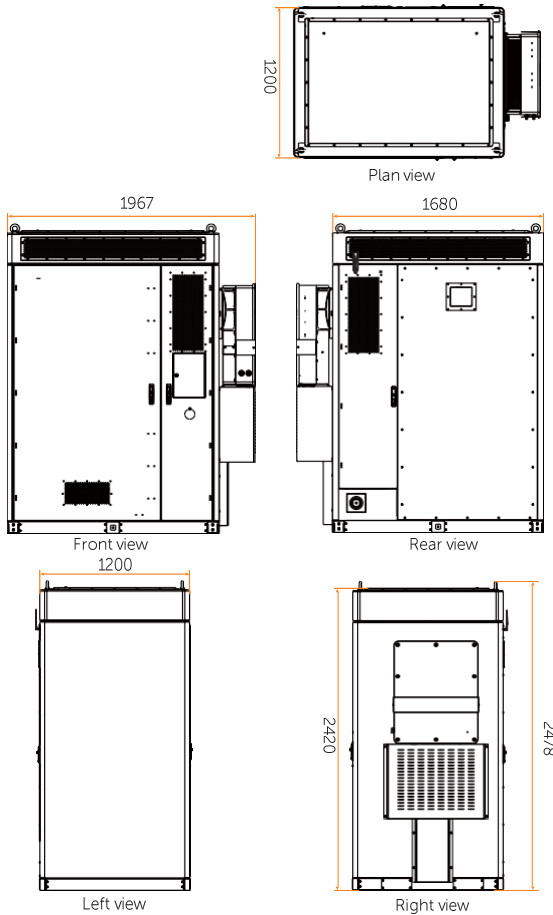

Figure 2-2 Dimension (unit: mm)

## 2.4 Parts Description

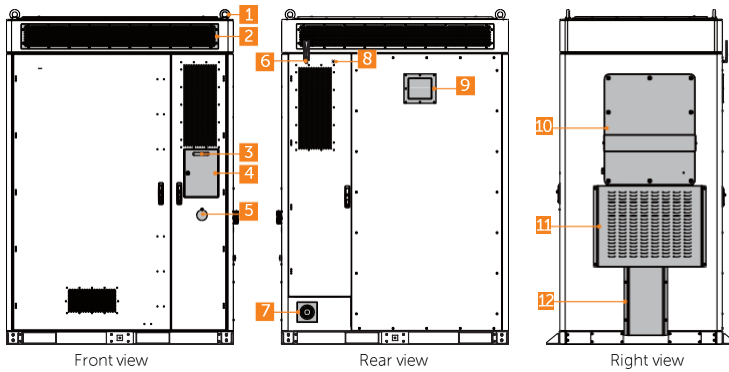

Figure 2-3 Parts description (in the closed state)

Table 2-1 Parts description

No.	Item	Description
1	Eye bolt	Material lifting applications.
2	Air conditioner	Energy storage system air conditioner.
3	LED light	To display status information of all processes running on the system.
4	Display screen	To display information of the whole system (The screen can be seen after opening the screen door).
5	Emergency stop button	To shut down the system in emergency circumstances.
6	Antenna	A 4G antenna, to connect EMS.
7	Fire hose nozzle	To connect the water supply sources.
8	A reserved antenna port	To connect wireless meter.
9	Expansion-proof valve	To exhaust the combustible gas out of the cabinet.
10	Inverter	SolaX's X3-AELIO inverter which is not delivered with the cabinet.
11	Large cable cover	To protect and secure cables.
12	Small cable cover	To protect and secure cables.

Inverter

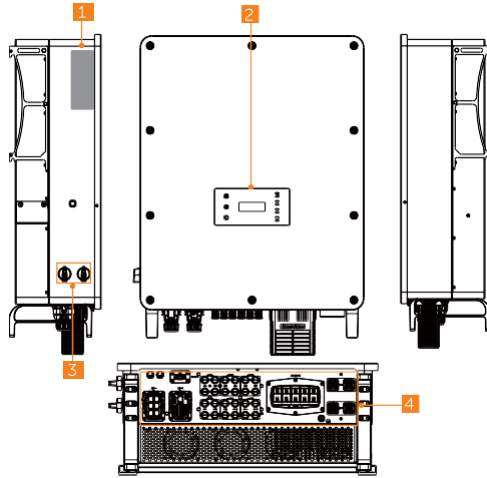

Figure 2-4 Parts description

Table 2-2 Parts description

No.	Item	Description
1	Type label	Type label clearly identifies the device type, serial number, specific DC / AC parameters, certification, etc.
2	LCD panel	Including screen, indicators and keys. Screen displays the information; indicators indicate the status of inverter. Keys are used to perform the parameter setting.
3	DC switch	Disconnect the PV DC input when necessary. DC switch 1 controls MPPT 1, 2 and 3, DC switch 2 controls MPPT 4, 5 and 6.
4	Electrical connection area	Including PV terminals, battery terminals, Grid and EPS terminals, communication terminals, etc.

## Battery cabinet

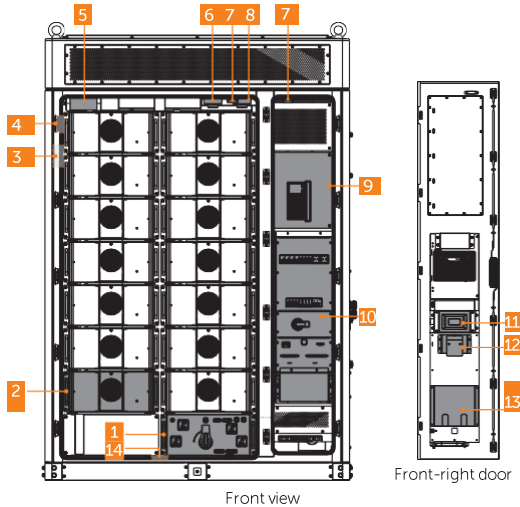
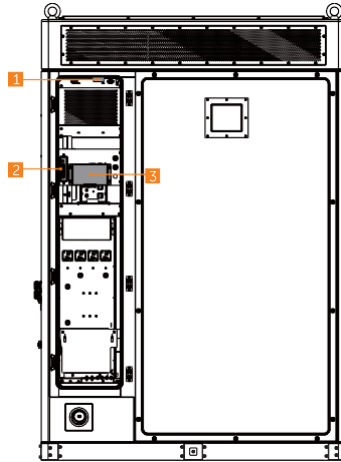

Figure 2-5 Parts description (in the opened state)

Table 2-3 Parts description

No.	Item	Description
1	High-voltage box	To collect current and voltage information on battery tower, ad control the charge and discharge of battery pack.
2	Battery pack	/
3	Temperature and humidity sensor	To measure temperature and humidity.
4	CO detector	To detect CO gases.
5	Automatic fire sprinkler	To control or suppress the spread of fire
6	Temperature sensor	To detect temperature.
7	Door sensor	To alert you when the door is open.
8	Smoke detector	To detect smoke.
9	Control area	Including IO module, EMS, UPS, etc. See Figure 2-7 for details.
10	Distribution box	To distribute AC power for the energy storage system.
11	Control panel of air conditioner	To monitor the air conditioner and show relevant parameter.

No.	Item	Description
12	Audible and visible alarm	To alert you when the abnormal conditions occur, such as temperature, smoke.
13	File pocket	To put documents.
14	Water sensor	To detect water level based on the principle of potential difference between the two electrodes.



Rear view

Figure 2-6 Parts description (in the opened state)

No.	Item	Description
1	Door sensor	To alert you when the door is open.
2	Switch	/
3	EMS	A energy management system.

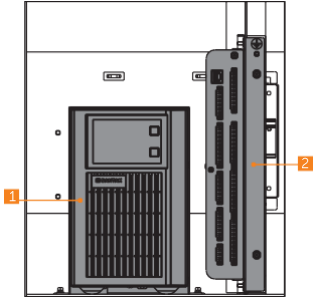

Figure 2-7 Parts description (control area)

Table 2-4 Parts description

No.	Item	Description
1	UPS	To provide backup power to ensure that the device is in a normal operating condition.
2	IO module	To collect signal and control other modules.

High-voltage box

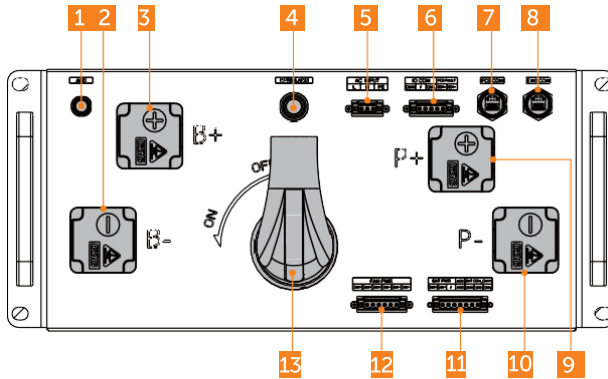

Figure 2-8 Front panel

Table 2-5 Description of front panel

No.	Item	Description
1	ADD button	To assign address.
2	Negative output port	To connect battery pack's negative terminal.
3	Positive output port	To connect battery pack's positive terminal.
4	Power button / status light	To start up or shut down system.
5	AC220V input terminal block	To connect distribution box's CZ1.
6	Communication terminal block (for IO module)	To connect the IO module's CAN port and dry contact of the inverter.
7	Communication port (for inverter)	To connect inverter's communication port.
8	Communication port (for EMS)	To connect EMS's communication port.
9	P+ port	To connect inverter's positive terminal.
10	P- port	To connect inverter's negative terminal.
11	Terminal block (for battery pack)	To connect battery pack's communication cable and power cable.
12	Terminal block (for fan)	To connect fan's power cable.
13	Disconnect switch	To disconnect the device on the DC side.

## Battery pack

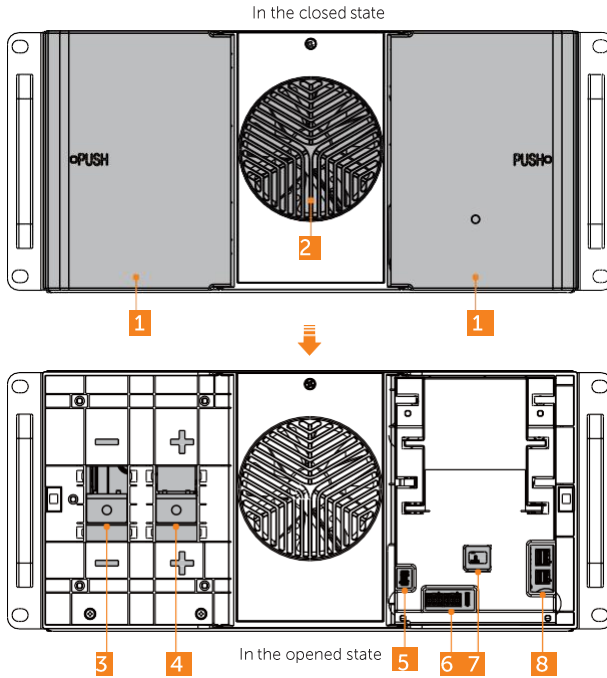

Figure 2-9 Front panel

Table 2-6 Description of front panel

No.	Item	Description
1	Left/right door	Please open the door while wiring.
2	Fan	To keep components cool in the cabinet.
3	Negative terminal	To connect negative terminal of high-voltage box or battery pack.
4	Positive terminal	To connect positive terminal of high-voltage box or battery pack.
5	Connection port (for fan)	To connect the fan.
6	Power connector (for fan)	To provide power to the fan.
7	BMS's status light	To display the running status of BMS.
8	Communication port	To connect communication cable.

Distribution box

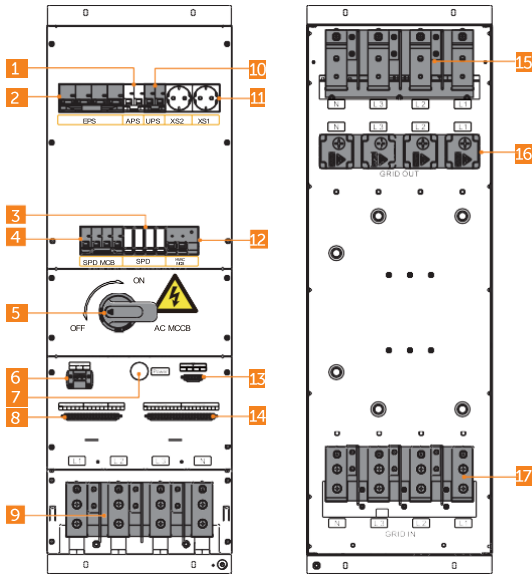

Figure 2-10 Front panel

Table 2-7 Description of front panel

No.	Item	Description
1	EPS breaker	EPS protection breaker.
2	Auxiliary power breaker of high-voltage box	/
3	Current terminal	To connect to the grid.
4	SPD maintenance breaker	/
5	Breaker handle	A switch for AC side.
6	Power supply port for air conditioner	To connect to the air conditioner.
7	LED light	To display the operation state.
8	220 V power supply port for controlling emergency stop switch	Provides 220V power for other devices in the cabinet. To manually turn off AC side for emergency.
9	EPS out	Connect EPS to loads.
10	UPS breaker	To protect UPS breaker.

No.	Item	Description
11	Socket	Power socket.
12	Air conditioner/liquid cooling unit on/off breaker	/
13	Circuit breaker's electrical control signal	To remotely turn off AC power for emergency.
14	24V power supply port	To provide power supply for the devices inside the cabinet.
15	EPS in	
16	Grid out wire connector	For AC side
17	Grid in wire connector	Port for connecting to power grid.

IO module

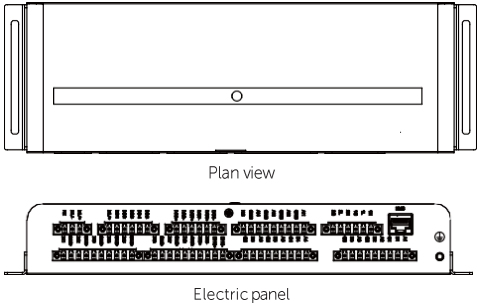

Figure 2-11 IO module

Other parts

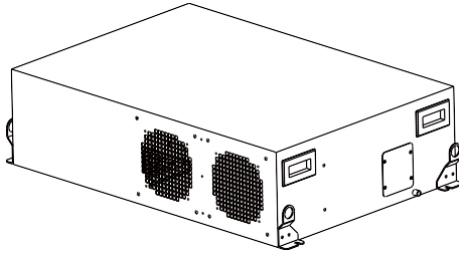

Figure 2-12 Appearance of air conditioner

NOTICE!

- Please refer to when “11.4.1 Disassembly and Clean of Air Conditioner Filter” it’s time to clean or replace the air conditioner filter.

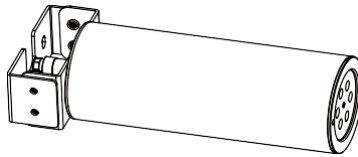

Figure 2-13 Appearance of automatic fire sprinkler

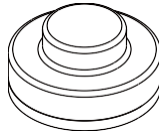

Figure 2-14 Appearance of temperature sensor

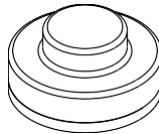

Figure 2-15 Appearance of smoke detector

NOTICE!

- A cover has been fitted on the temperature sensor and smoke detector, respectively, at the factory. Therefore, the please remove covers before using them.

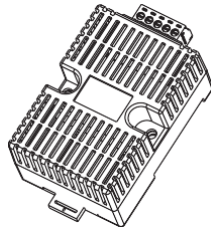

Figure 2-16 Appearance of temperature and humidity sensor

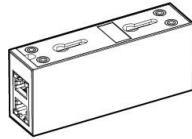

Figure 2-17 Appearance of CO detector

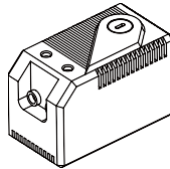

Figure 2-18 Appearance of temperature and humidity sensor

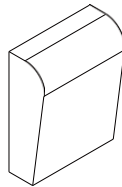

Figure 2-19 Appearance of audible and visible alarm

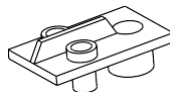

Figure 2-20 Appearance of water sensor

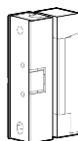

Figure 2-21 Appearance of door sensor

## 2.5 Indicator

### Cabinet's LED light

The cabinet is equipped with a tri-colour indicator (green/yellow/red) to show the system operating status.

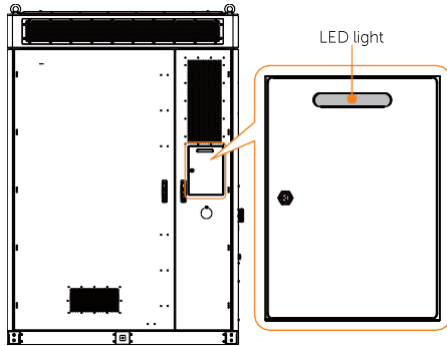

Figure 2-22 LED light

Table 2-8 Description

Status		Description
Light on		In standby
Light on		In operation
Light on		System failure

### High-voltage box's indicator light

The box is equipped with a bi-colour indicator (green/red) to show its operating status.

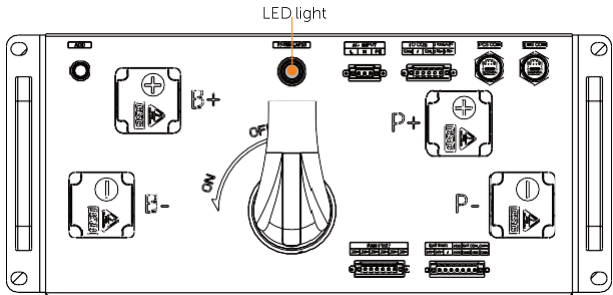

Figure 2-23 LED light

Table 2-9 Description

Status		Description
Blinking		In operation
Light on		Rely in off state
Light on		System failure

### Battery pack's LED light

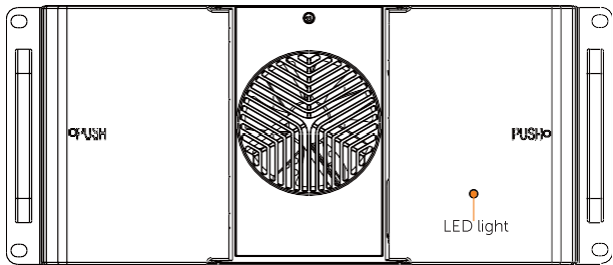

Figure 2-24 LED light

Table 2-10 Description

Status		Description
Blinking		In operation

### Inverter control panel

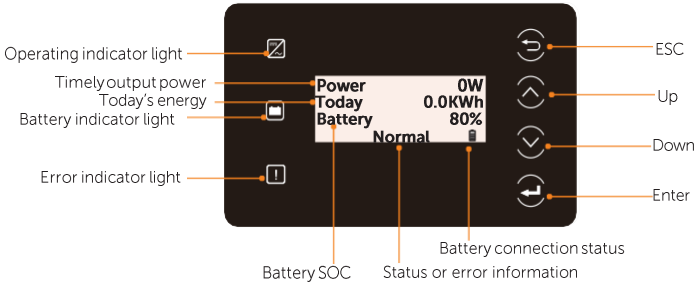

























Figure 2-25 Control Panel

Table 2-11 Description

LED indicator	Status	Definition
 Operating	Light on	 The inverter is in a normal state.
	Blinking	 The inverter is in a waiting or checking state.
 Error	Light on	 The inverter is in a fault state.
	 Battery	Light on
Blinking		 Both of the battery terminals are connected are in an idle state.
 Battery connection status	Solid display	 One of the battery terminals is connected normally at least.
	Blinking	 Both of the battery terminals are disconnected.

## 2.6 Symbols

Table 2-12 Description of symbols

Symbol	Description
	CE mark of conformity.
	TUV certification.
	RCM mark of conformity
	Protective grounding point.
	Grounding point.
	Caution, hot surface. The enclosure temperature may be high while running. Therefore, do not contact to avoid scalding.
	Danger, electric shock. Do not touch the device after it is powered on. Otherwise, an electric shock may occur.
	Danger. Due to possible risks, do not touch the device after it is powered on.
	Observe enclosed documentation.
	The device cannot be disposed together with the household waste.
	Do not operate the inverter until it is isolated from mains and on-site PV generation suppliers.
	Danger of high voltage. Do not touch live parts for 15 minutes after disconnection from the power sources.
	Danger to life due to high voltage. Residual voltage exists after the inverter is powered off, which needs 5 minutes to fully discharge. Wait 5 minutes before attempting any service.
	The battery system must be disposed of at a proper facility for environmentally-safe recycling.



The battery module may explode.  
The rechargeable battery can become hot during operation. Avoid touch during operation.



Keep the device away from children.



Keep the device from open flames or ignition sources.

## 2.7 Working Mode

Six working modes are available for you to choose in on-grid status, i.e Self use, Feed-in priority, Backup, Peak shaving, Schedule and Manual. You can choose the working modes according to your lifestyle and environment.

When the power supply from the electric power company is stopped due to a power outage, it automatically switches to EPS mode and connects to the distribution board for a specific load, thereby providing power to important electrical appliances.

For how to set the working mode, please refer to the X3-AELIO Series User Manual.

### 2.7.1 Self-use Mode (Priority: Loads > Battery > Grid)

The self-use mode is suitable for areas with low feed-in subsidies and high electricity prices. The power of PV will supply the loads first, and the surplus power will charge the battery, then the remaining power will feed into the grid.

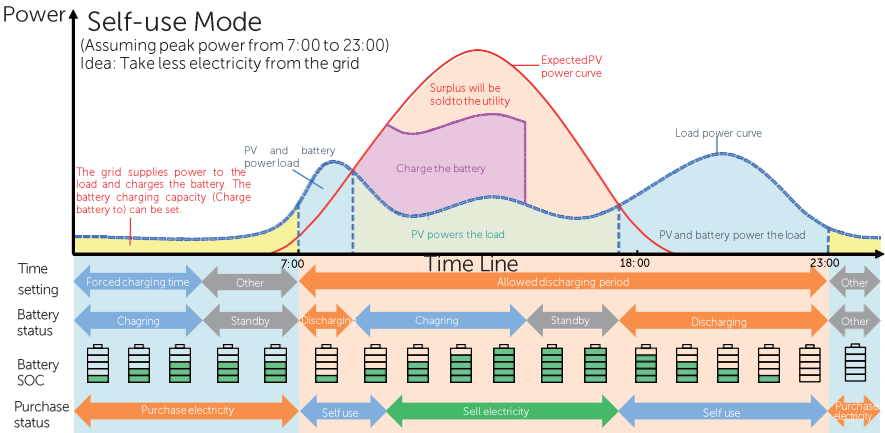

Figure 2-26 Self-use mode

Table 2-13 Description of self-use mode

Time period	Inverter working status
Forced charging period	<ul style="list-style-type: none"> <li>Charge the battery firstly until the battery SOC reaches the specified <b>Charge battery to</b> value. You can configure the inverter to either draw power from the grid or not.</li> </ul>
Allowed discharging period	PV is sufficient (PV → load → battery → grid) <ul style="list-style-type: none"> <li>The power generated from PV prioritizes supplying the load. Any excess power is then directed towards charging the battery, and if there is still surplus electricity, it can be sold to the grid. In the event that the local utility restricts the sale of electricity to the grid, the export control value can be set on the inverter.</li> </ul>
	PV is insufficient (PV+battery → load) <ul style="list-style-type: none"> <li>The battery discharges power to the load, and once its capacity reaches <b>Min SOC</b>, it automatically ceases discharging.</li> </ul>

**Note:**

**Charge battery to:** The battery SOC charged from grid. 10% by default, the settable range is 10%~100%.

**Min SOC:** Minimum SOC of the battery under grid connection. 10% by default, the settable range is 10%~100%.

## Charge & Discharge period

You can set two configurable working periods: forced charging period and allowed discharging period. The interval not in the charging & discharging period belongs to other time periods.

- Forced charging period (Default period: 00:00~00:00, closed by default)

The priority of forced charging period is higher than all working modes. In the forced charging period, the inverter will charge the battery first until the battery SOC reaches the specified **Charge battery to** value set in each working mode. You have the option to configure the inverter to either draw power from the grid or not.

- Allowed discharging period (Default period: 00:00~23:59)

In the allowed discharging period, the inverter will allow the battery to discharge and charge power in accordance with the working mode and load conditions.

- Period not set as forced charging or allowed discharging period

In this period, the inverter will allow the battery to charge but can not discharge power.

**NOTICE!**

- The charging and discharging period is only applicable for self-use mode, feed-in priority and backup mode.

**2.7.2 Feed-in Priority (Priority: Loads > Grid > Battery)**

The feed-in priority mode is suitable for areas with high feed-in subsidies, but has feed-in power limitation. The power generated from PV is directed towards supplying the loads. Any excess power beyond the load requirements will be fed into the grid.

Note: If the amount of electricity sold to the grid is limited, the remaining power will be utilized to charge the battery.

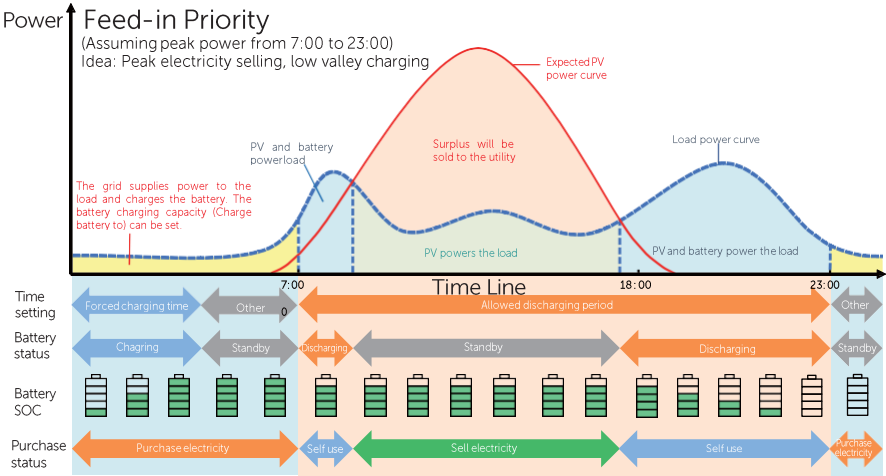

Figure 2-27 Feed-in priority

Table 2-14 Description of feed-in priority

Time period	Inverter working status
Forced charging period	<ul style="list-style-type: none"> <li>Charge the battery firstly until the battery SOC reaches the specified <b>Charge battery to</b> value. You can configure the inverter to either draw power from the grid or not.</li> </ul>
Allowed discharging period	PV is sufficient (PV → load → grid) <ul style="list-style-type: none"> <li>The power generated from PV is directed towards supplying the loads. Any excess power beyond the load requirements will be fed into the grid,</li> </ul>
	PV is insufficient (PV+battery → load) <ul style="list-style-type: none"> <li>PV and battery supply power to the load at the same time, and once the battery capacity reaches <b>Min SOC</b>, it automatically ceases discharging.</li> </ul>

**Note:**

**Charge battery to:** The battery SOC charged from grid. 50% by default, the settable range is 10%~100%.

**Min SOC:** Minimum SOC of the battery under grid connection. 10% by default, the settable range is 10%~100%.

**NOTICE!**

- You can set two configurable working periods: forced charging period and allowed discharging period in feed-in priority mode. Please refer to “Charge & Discharge period” for details.

### 2.7.3 Backup Mode (Priority: Loads > Battery > Grid)

The backup mode is suitable for areas with frequent power outages.

This mode will maintain the battery capacity at relatively high level to ensure that the emergency loads can be used when grid is off. Same working logic with self-use mode.

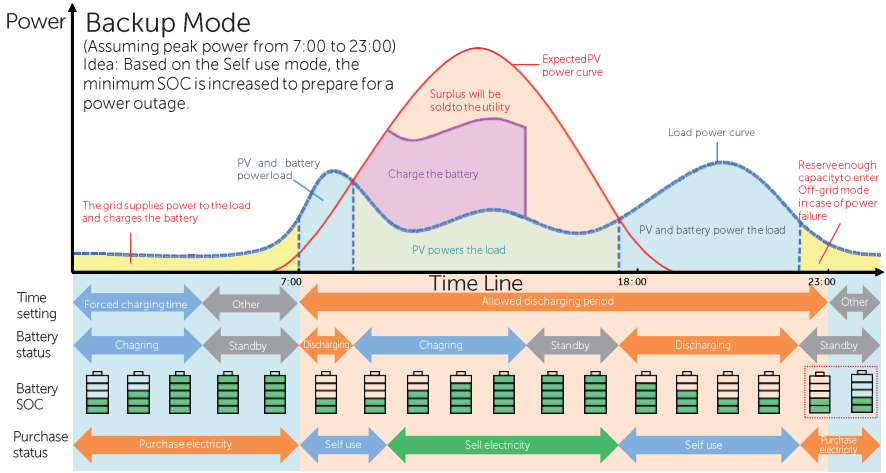

Figure 2-28 Backup mode

Table 2-15 Description of backup mode

Time period	Inverter working status
Forced charging period	<ul style="list-style-type: none"> <li>Charge the battery firstly until the battery SOC reaches the specified <b>Charge battery to</b> value. You can configure the inverter to either draw power from the grid or not.</li> </ul>
Allowed discharging period	<ul style="list-style-type: none"> <li>The working logic remains the same as for self-use mode, but it enters a standby state when PV input is not available and the battery SOC reaches <b>Min SOC</b> (on-grid min SOC). In the event of a grid outage, it will switch to EPS mode until the battery discharges to <b>Min SOC</b> (Off-grid min SOC).</li> </ul>

**Note:**

**Min SOC** (on-grid min SOC): Minimum SOC under grid connection. 30% by default, the settable range is 30%~100%.

**Min SOC** (off-grid min SOC): Minimum SOC under off-grid conditions. 10% by default, the settable range is 10%~100%.

**NOTICE!**

- You can set two configurable working periods: forced charging period and allowed discharging period in backup mode. Please refer to “Charge & Discharge period” for details.

### 2.7.4 Peak Shaving Mode

Peak shaving mode is set for leveling out peaks in electricity use. The system is intelligently controlled to ensure charging takes place during off-peak hours and discharging occurs during peak hours.

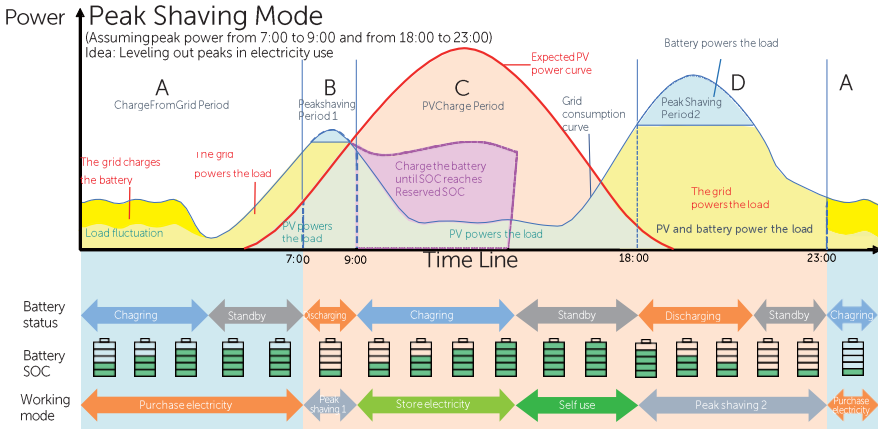

Figure 2-29 Peakshaving mode

Table 2-16 Description of peakshaving mode

Time Period	Inverter working status
Period A	<ul style="list-style-type: none"> <li>The grid can charge the battery to <b>MaxSOC</b> within the set <b>ChargePowerLimits</b>. In this period, the battery will not discharge power.</li> </ul>
Period B & D	<p>Grid consumption power &lt; <b>PeakLimits</b>                      (PV+grid → load)</p> <ul style="list-style-type: none"> <li>The PV and grid will power the load. The battery will not charge or discharge power.</li> </ul>
Period C	<p>Grid consumption power &gt; <b>PeakLimits</b>                      (PV + battery+grid → load)</p> <ul style="list-style-type: none"> <li>The battery will discharge energy for loads and thus reduce the amount of energy purchased from the grid.</li> </ul> <p>(PV → battery → load → grid)</p> <ul style="list-style-type: none"> <li>The battery does not discharge power. The PV charges the battery up to the <b>Reserved SOC</b> before supplying power to the loads. Any excess power beyond the load requirements is fed into the grid.</li> </ul>

**Note:**

**MaxSOC:** The energy taken from grid to charge the battery. 50% by default, the settable range is 10%-100%.

**ChargePowerLimits:** The charging power from grid. 1000 W by default, the settable range

is 0-60000 W

**PeakLimits:** The load consumption from grid side. 0 W by default, the settable range: 0-60000 W.

**Reserved SOC:** The lower limit of battery SOC required for later peak shaving period. 50% by default, the settable range is 10~100%.

### 2.7.5 TOU Mode

In the TOU mode, different working modes, i.e Self-use, Feedin-priority, Peaking shaving, Charging and Discharging can be set for different time periods in accordance with actual needs and environment conditions through SolaXCloud App or Web.

The day can be divided into up to 24 time slots, and the minimum time slot is 15 minutes, independent working mode can be set for each time slot. Please refer to Web Guide or App Guide for details about how to set the TOU mode.

---

Time Slot	Working Mode
x:xx~x:xx (e.g 0:00~0:15)	Choose one mode from Self-use / Feedin-priority / Peaking shaving / Charging / Discharging

---

**Note:**

Self-use: Same working logic with "Self-use Mode", but it is not limited by the charging and discharging time slots. The priority of PV: Loads > Battery > Grid.

Feedin-priority: Same working logic with "Feedin-priority Mode", but it is not limited by the charging and discharging time slots. The priority of PV: Loads > Grid > Battery.

Peak Shaving: The working logic is that when the power consumption from the grid exceeds the set **PeakLimit** value, the battery is allowed to discharge power. The excess power beyond the limit is provided by the combination of photovoltaic and battery to ensure that the maximum power purchased from the grid does not exceed the set limit. You need to set the **PeakLimit** value through Web or App when choosing Peak Shaving mode.

Charging: The power of PV will charge the battery as much as possible to the set SOC of **Charge BAT to (%)**. You can set whether to Charge from grid. The default value of **Charge BAT to (%)** is 100%. When the battery reaches the set SOC, the surplus power will perform "Self-use Mode" or supply to the grid ( based on the system setup), at this point, **Charge from grid** is not allowed.

Discharging: If allowed by the battery, the system outputs a specified power from the grid based on the set output percentage, controlling the power at the AC port. You need to set the **RatePower (%)** through Web or App when choosing Discharging mode. When the battery **Discharge to (%)** reaches the set SOC, the inverter performs "Self-use Mode".

### 2.7.6 EPS Mode (Priority: Loads > Battery)

During a power failure, the system will provide uninterrupted power supply to the EPS loads using the power from PV and the battery. It is important to ensure that a battery is installed, and the EPS loads should not exceed the maximum output power of the battery.

The power generated by PV will prioritize supplying power to the loads, while any surplus power will be utilized to charge the battery.

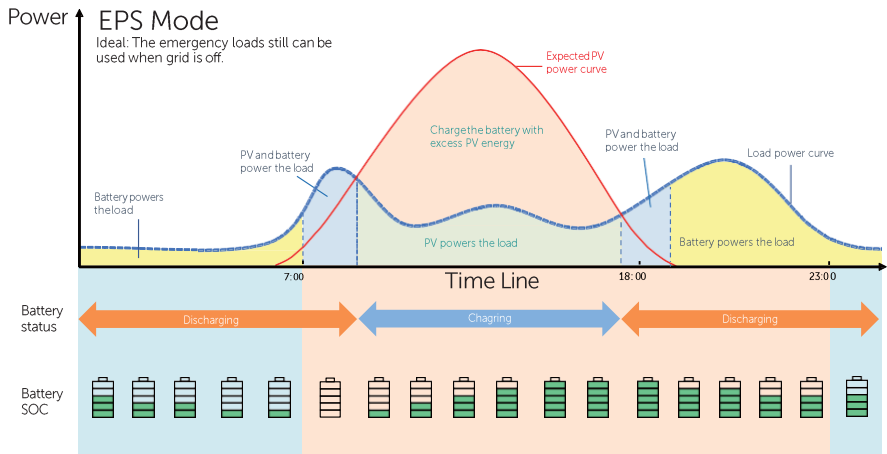

Figure 2-30 EPS mode

Table 2-17 Description of EPS mode

Battery SOC	Inverter working status
Battery SOC > <b>Min SOC</b> (off-grid min SOC)	PV is sufficient (PV → load → battery) <ul style="list-style-type: none"> <li>The PV prioritizes supplying power to the load, with any excess energy being directed towards charging the battery.</li> </ul>
Battery SOC < <b>Min SOC</b> (off-grid min SOC)	PV is insufficient (PV+battery → load) <ul style="list-style-type: none"> <li>The PV prioritizes supplying power to the load. If the energy is not enough, the battery will discharge power until the battery SOC reaches <b>Min SOC</b> and then error of <b>BatPowerLow</b> will be reported.</li> </ul>
Battery SOC < <b>Min SOC</b> (off-grid min SOC)	The inverter reports <b>BatPowerLow</b> . When there is PV, it will charge the battery first. After charging to the set <b>Min ESC SOC</b> value, it will be automatically recovered and enter EPS mode again.

**Note:**

**Min SOC:** Minimum SOC of the battery under off-grid conditions. 10% by default, the

Product Overview

settable range: 10%-100%.

---

**Min ESC SOC:** The minimum SOC of the battery to enter EPS mode. 30% by default, the settable range: 15%-100%.

## 2.7.7 Manual Mode

This working mode is only for the after-sales team to do after-sales maintenance. It includes **Forced Discharge**, **Forced Charge** and **Stop chrg&dischrg**. The system will restore to the original working mode after six hours Manual mode set.

## 2.7.8 Export Control Function

Solar export control is a limit on the amount of energy that your solar system can export into the grid. You have a set limit on how much energy you can export to the grid.

### How export control works

- CT/meter required
- Correct setting of the limit value of **Export Control** through inverter. (For parallel system, set on the master inverter)

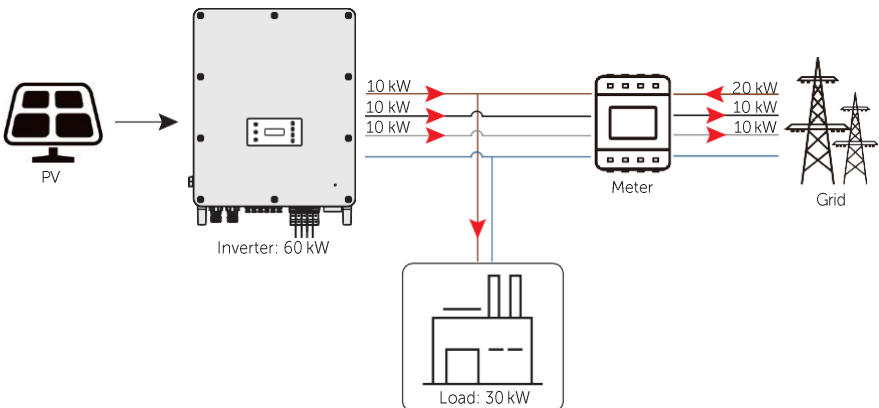

Figure 2-31 Zero export control with **Phase Unbalance** disabled

### NOTICE!

- The power taken from the grid is equal to the power fed into the grid.

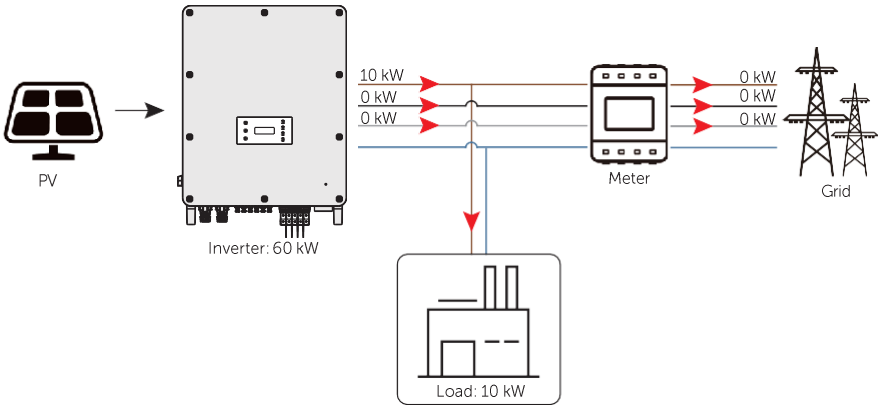

Figure 2-32 Zero export control with **Phase Unbalance** enabled

**Note:**

**Export Control** value can be set from 0W to more than the rated output power.

## 2.8 Application Schemes

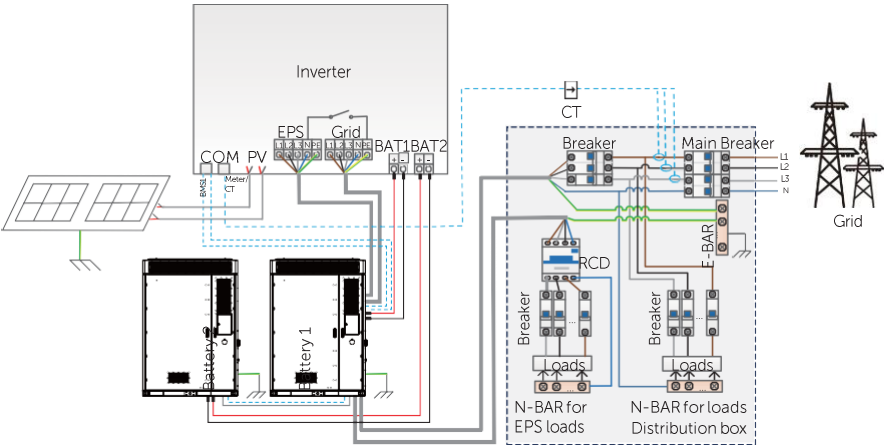

Figure 2-33 Partial load backup for Europe

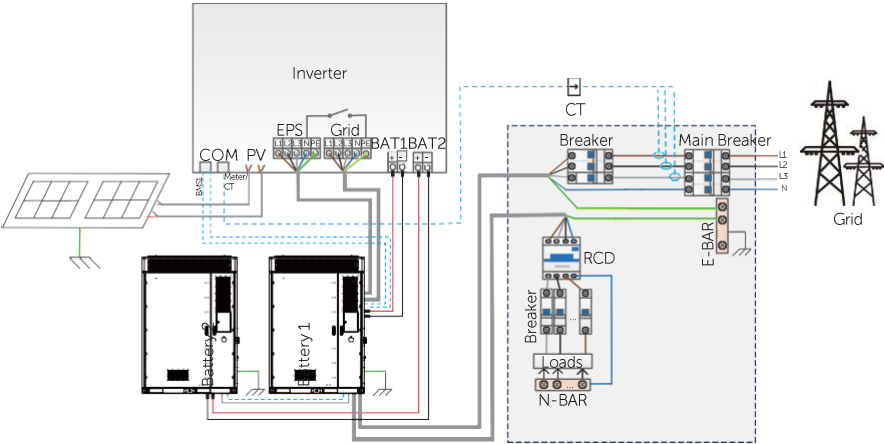

Figure 2-34 Whole load backup for Europe

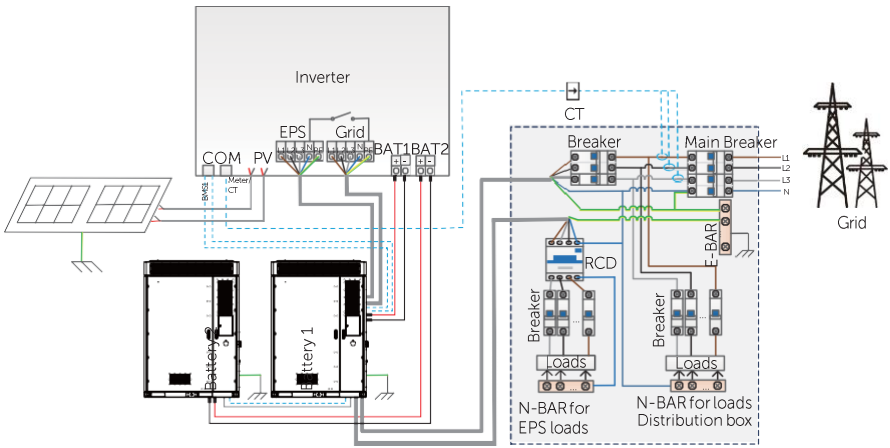

Figure 2-35 Partial load backup for Australia

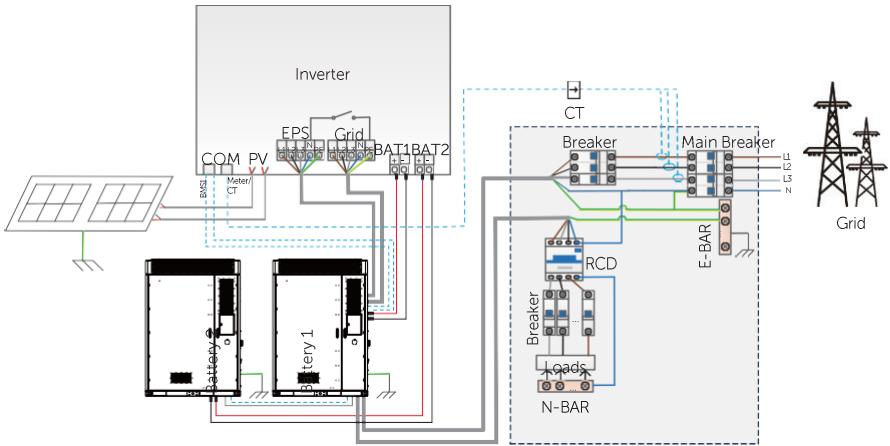

Figure 2-36 Whole load backup for Australia

**NOTICE!**

- The BAT 1 and BAT2 terminals of the inverter are positioned vertically, with the positive pole on the left side and the negative pole on the right side. The battery terminals shown in the figure above are for illustrative purposes only, please refer to the actual product for accurate information.

## 2.9 Operating Principle

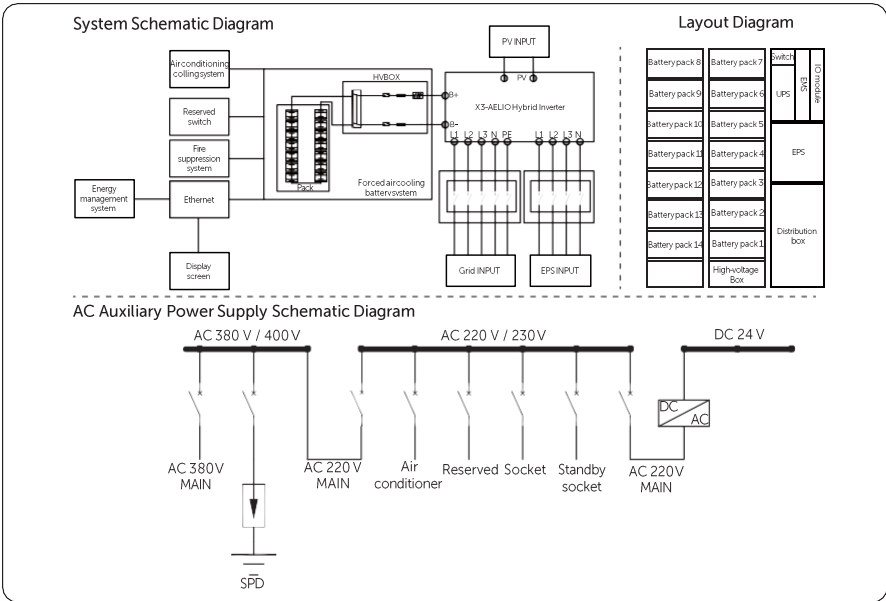

Figure 2-37 Electrical block diagram

### NOTICE!

- In an off-grid situation, the current will vary due to the types of electrical loads. The common electrical load can be classified into following types, resistive load, inductive load, capacitive load, half-wave load, etc. Therefore, the types of electrical loads shall be fully considered when designing and configuring a system. In the case of a half-wave load, the load power shall not exceed 1 kW; in the case of an uncertain electrical load, please contact the supplier for evaluation of output supply to special loads.



# 3 Transportation and Storage

---

## 3.9.1 Battery Cabinet Transportation

### DANGER!

- Please be careful to avoid physical collisions during transportation. Do not place the equipment upside down, be exposed to water, etc., which may result in equipment damage, or even a fire or an explosion.

### NOTICE!

- Please strictly comply with the transportation requirements of the warning signs on the packaging and equipment.
- The tilt angle of the cabinet should be  $\leq 10^\circ$  while transporting and moving it.
- To reduce product damage caused by shocking, tilting or impacting during transportation, it is recommended to consider sea or road (with better conditions) transport instead of rail and air transports.
- Relevant qualifications for the transport of dangerous goods must be obtained by the forwarding agent engaged in such businesses, and they must strictly abide by the local regulations for the transport of dangerous goods. Please check the battery before transportation. If a battery leaks, smells, or is damaged, do refuse to transport it.

### Forklift

- Please confirm that the forklift's load-bearing capacity shall be  $\geq 5$  t before using it.
- The forklift should meet the following requirements: length of fork blade  $> 1.2$  m, width of fork blade between 80 cm and 160 cm, and thickness of fork blade between 25 cm and 70 cm.

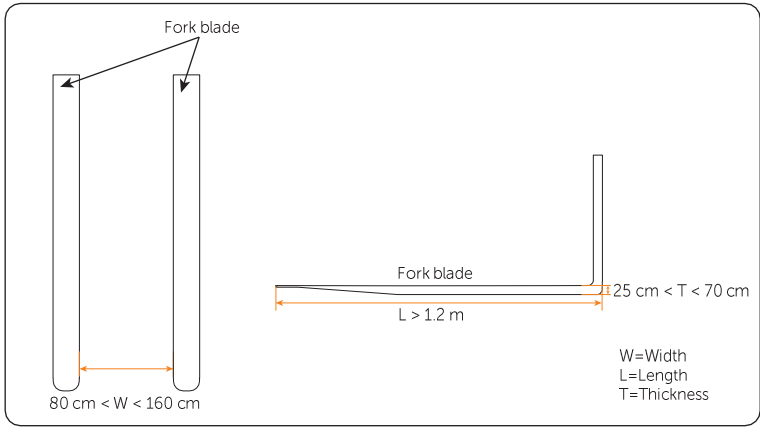

Figure 3-1 Forklift requirements

- Before moving the device, please pay attention to the center of gravity position of the load, and fully secure the load on the forklift by securing measures, such as ropes or bindings. In addition, please designate a person to supervise for safety concerns during transportation.
- Before unpacking, please accurately insert the fork blade into the fork holes on the carton when moving the device.

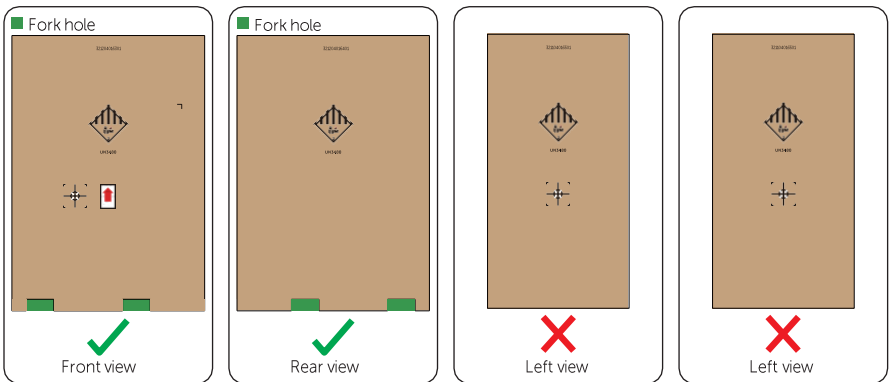

Figure 3-2 Carton fork holes

- For specific fork holes after unpacking, please refer to "6.1 Cabinet Handling".
- The equipment can only be transported by forklift before unpacking.

## Hoisting

- A hoist operator with good operational skills and safety awareness, who must be trained and certified, shall be operated according to the local laws and regulations.
- After unpacking, the following requirements must be met when working with cranes and lifting ropes: crane hoisting capacity  $\geq 5$  t, hoisting operating radius  $\geq 2$  m.
- Before hoisting, please check:
  - » Lifting tools are complete, tested and fully secured.
  - » The device door is closed and locked to avoid accidental opening.
  - » The lifting rope's quality must meet standards, and it shall be fully secured, to avoid falling and fraying.
- Do not hoist outdoors in rain, snow, wind and other bad weather.
- It is recommended to hoist devices in sequence and to ensure that the hoist moves in the same direction.

### 3.9.2 Inverter Transportation

If the inverter is not put into use immediately, the transportation and storage requirements needs to be met:

- Observe the caution signs on the packaging of inverter before transportation.
- Pay attention to the weight of inverter. Be cautious to avoid injury when carrying X3-AELIO (gross weight: 130 kg). Lifting device is recommended.
- The inverter with a package should be transported by forklift to the location where it needs to be placed.

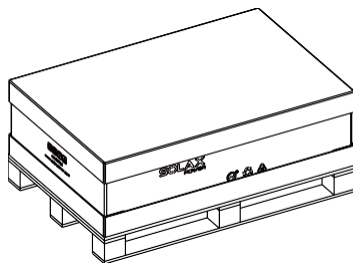

Figure 3-3 Caution signs on the packaging

## 3.1 Storage

### 3.1.1 Cabinet Storage

- For long-term storage, do not remove the original packaging and check the packaging regularly.
- Please strictly comply with the storage requirements of the warning signs and other information on the packaging to avoid device damage.
- Storage temperature:  $-20^{\circ}\text{C} \sim +60^{\circ}\text{C}$ .
- Relative humidity for device storage: 5% ~ 95%.

#### NOTICE!

- Since the batteries have been installed in the cabinet in the factory, the storage requirements for the battery must also be abided by when storing the cabinet.

### Battery storage

#### DANGER!

- The battery must be stored indoors, which the environment should meet the following requirements: 1. Avoiding direct sunlight and keeping out of rain; 2. Dry and well-ventilated; 3. Keeping away from heat and fire sources; 4. Keeping away from radiation; 5. Keeping away from chemicals; 6. Keeping away from dust and metal conductive dust; 7. Being equipped with fire facilities.
- Batteries must be stored in accordance with the requirements of the warning signs and other information on the packaging.
- Do not store with any other electronic equipment, chemicals, or other items that may cause interference or danger.
- Please pay attention to the height when stacking batteries to avoid deforming or damaging the battery at the bottom.

#### NOTICE!

- Do not store the batteries for a long time. If long periods of storage are unavoidable, please recharge it periodically to avoid battery damage. For details, see the table below.

Table 3-1 Maintenance of battery pack

Circumstance	Measure
If the ambient temperature for storage is between 30°C and 50°C	Recharge the battery packs at least once every 6 months
If the ambient temperature for storage is between -20°C and 30°C	Recharge the battery packs at least once every 12 months.
In the first installation	The interval among manufacture dates of battery packs shall not be exceed 3 months.
If a battery module is replaced or added for capacity expansion	Each battery's SOC should be consistent. The max. SOC difference should be $\pm 5\%$ .
If users want to increase their battery system capacity	Ensure that the SOC of the existing system capacity is about 40%. The manufacture date of the new battery pack shall not exceed 6 months. If the manufacture date of the new one exceeds 6 months, please charge it to around 40%.

- Regarding with the storage information, see the following table:

Table 3-2 Storage information

Storage temperature range	Storage time
50°C to 60°C	3 months
30°C to 50°C	6 months
-20°C to 30°C	12 months

- Relative humidity for device storage: 5% ~ 95%.
- If the battery has been stored for more than 1 year, it must be checked and tested by professionals before use.

### 3.1.2 Inverter Storage

- The inverter must be stored indoors.
- Do not remove the original packaging material and check the outer packaging material regularly.
- The storage temperature should be between -40°C and +70°C . The humidity should be between 0% and 65%.
- Stack the inverter in accordance with the caution signs on the inverter carton to prevent their falling down and device damage. Do not place it upside down.

# 4 Preparation before Installation

---

## 4.1 Installation Site Selection

The installation site is critical to the safety, service life, and performance of the device, and it should be convenient for electrical connections, operation, and maintenance. Therefore, the installation site should be selected according to the *NFPA 855 Standard for the Installation of Stationary Energy Storage Systems* and the local laws and regulations.

The installation site shall meet the following requirements:

- **Laws, regulations and industry standards:** The selection of installation sites must strictly comply with local laws, regulations, and related industry standards.
- **Fire safety:** Fire extinguishers must be configured at the installation site according to the local fire codes, and a port for the water fire extinguishing system shall be reserved.
- **Outdoor installation:** This device can only be used outdoors.
- **Safety spacing:**
  - » The installation distance between the device and residential areas, population centers, or production buildings should meet the requirements of the local fire codes and standards.
  - » If the safety spacing cannot be met, a firewall that meets the requirements of the local fire codes must be built between the device and adjacent buildings. During the planning phase, it is crucial to consider the space for transportation, installation and maintenance of the device.
- **Flood and waterlogging prevention:**
  - » Avoid low-lying and flood-prone areas. The installation site that the device is to be located must be at least 300 mm higher than the highest water level in history.
  - » Since winds and wind-driven waves from rivers, lakes, and seas can affect the device, the foundation must be built at least 0.6 m higher than the maximum wave height in history.
  - » If a large amount of water flows in or through the energy storage power station, drainage facilities should be set up.
  - » If the installation site is prone to water accumulation, take waterproof measures, including but not limited to installing water baffles, configuring a drainage system, or raising the height of the foundation to prevent device damage.
- **Avoid liquid intrusion:** The installation area should be far away from the area where liquid is likely to be generated or leaked to avoid device failure.

- **Good transportation:** Good transportation for the installation site.
- **Reserve space:** During the planning phase, please consider the space for capacity expansion or connection in parallel in the future.
- **Avoiding bad soil:** Do not install devices on the undesirable soil that are prone to deformation and settlement.
- **Keeping away from salt-damaged and polluted areas:** Since the salt-damaged and polluted areas may corrode the device, the installation site must meet the following requirements:

Table 4-1 Installation spacing requirements

	Safety Distance
Distance from coastal areas	> 2000 m
Distance from heavy pollution sources, such as smelters, coal mines, thermal power plants	> 1500 m
Distance from moderate pollution sources, such as chemical plants, rubber plants, and electroplate factory	> 1000 m
Distance from light pollution sources, such as food processing plants, leather processing plants, heating boiler factory, slaughter houses, dumping sites, and sewage treatment stations	> 500 m

- **Additional fence:** For security reasons, the installation area should be surrounded by locking fences or walls accessible to qualified persons only.
- **Installation environment requirements:**
  - » Temperature:  $-30^{\circ}\text{C} \sim +50^{\circ}\text{C}$ .
  - » Relative humidity:  $0 \sim 100\% \text{ RH}$ .
  - » Altitude: Below 3000 meters.
  - » Good ventilation.
  - » Keep away from sandy and dusty environments.
  - » Keep away from high temperature environment such as heat source and fire source, etc.
  - » Keep away from flammable and explosive materials and areas with dust.
  - » Keep away from corrosive substances.
  - » Keep away from strong electromagnetic fields and antenna.
  - » Keep away from strong vibration and noise sources.
  - » Keep away from areas with radiation.
  - » Keep away from areas with metal conductive and magnetic dust.
  - » Keep away from areas that produce or have toxic and harmful gases.
  - » Keep away from environments that are prone to microbial growth.

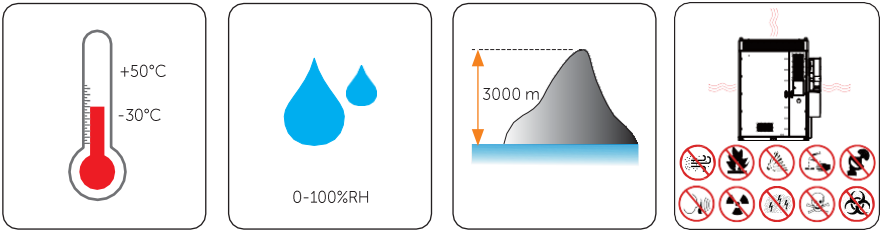

Figure 4-1 Installation environment requirements

### 4.1.1 Installation Foundation Requirements

The requirements for foundation are shown as follows:

- Type of foundation material: 1. Non-combustible materials such as solid bricks or concrete; 2. Steel.
- The bottom of the foundation pit must be strengthened and filled. The surface of the foundation shall be solid, flat and level (horizontal error  $\leq 3\text{mm}$ , tilt angle  $\leq 5^\circ$ ). Sunken or tilted foundation is not acceptable.
- The foundation's bearing capacity shall exceed 5 t. Otherwise, a retest is required.

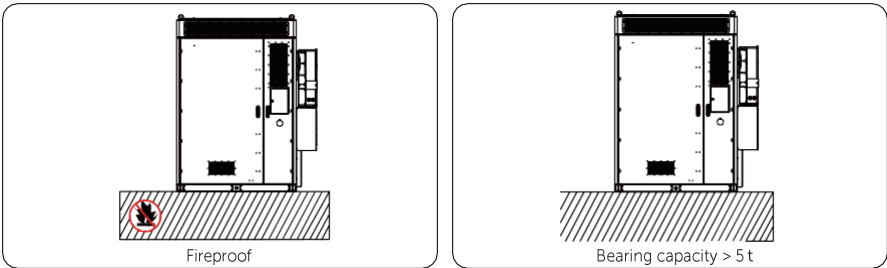

Figure 4-2 Foundation requirement

- A qualified drainage facility, of which the drainage capacity meets the requirements of the heaviest rain records in local history, shall be established according to the local geological conditions and municipal drainage standards.
- Reserve a trench or cable entry hole during the design phase.
- Avoid cables buried underground when constructing the foundation.
- The foundation drawing is only for reference. Operators shall recheck and revise it according to the environment, geological conditions, seismic requirements, etc. of the installation site.

Concrete foundation

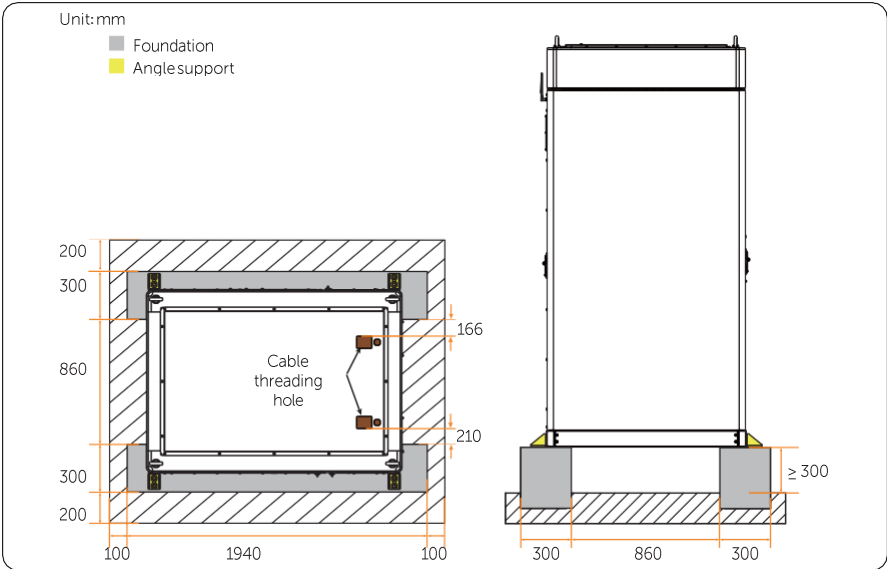

Figure 4-3 Foundation requirements for angle supports installed at front and rear sides

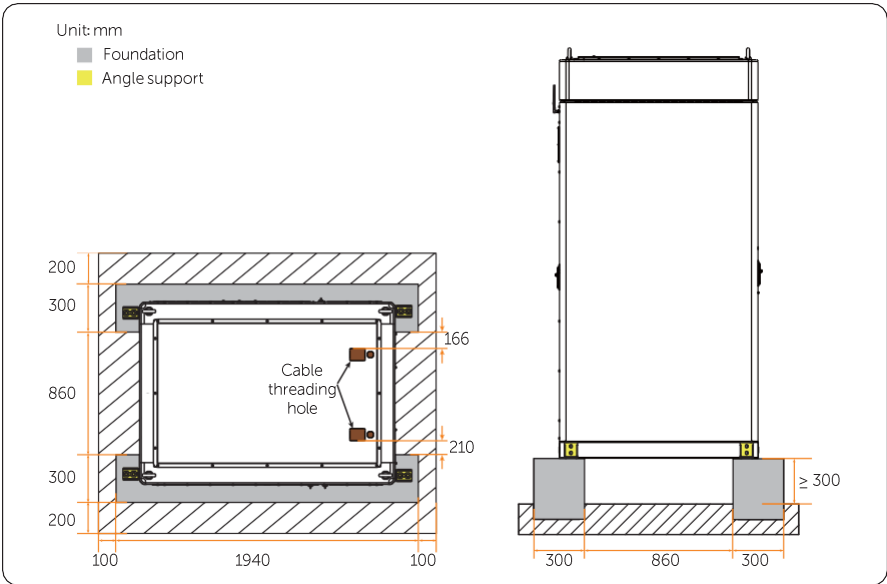

Figure 4-4 Foundation requirements for angle supports installed at left and right sides

### Steel foundation

If users want the foundation to be made of steel, the foundation must meet the following requirements:

- Bearing capacity: > 5 t;
- Corrosion resistance: it is recommended to be subjected to a 720 hrs salt spray test;
- Dimension and others: see the following figures.

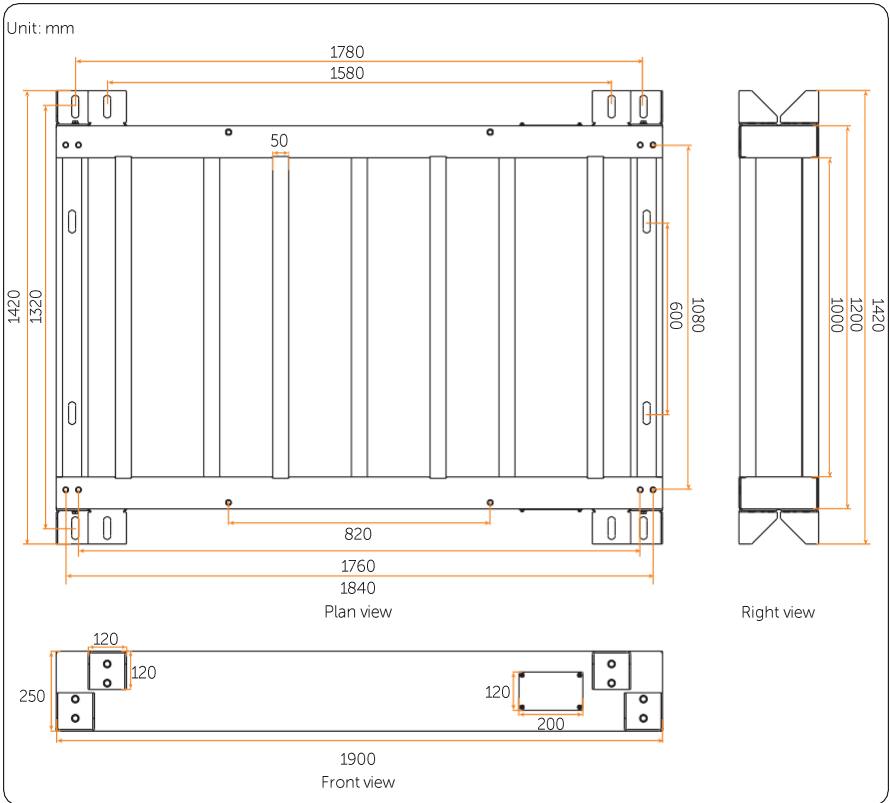

Figure 4-5 Dimension of steel foundation

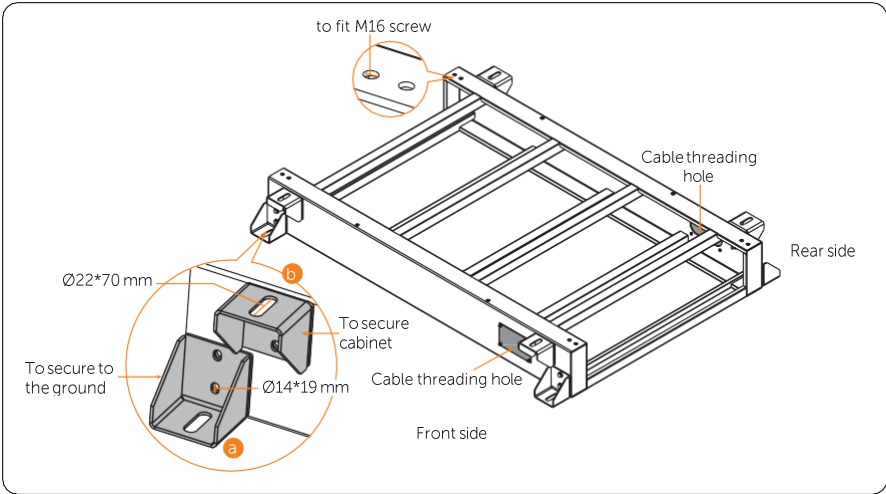

Figure 4-6 Detail description of steel foundation

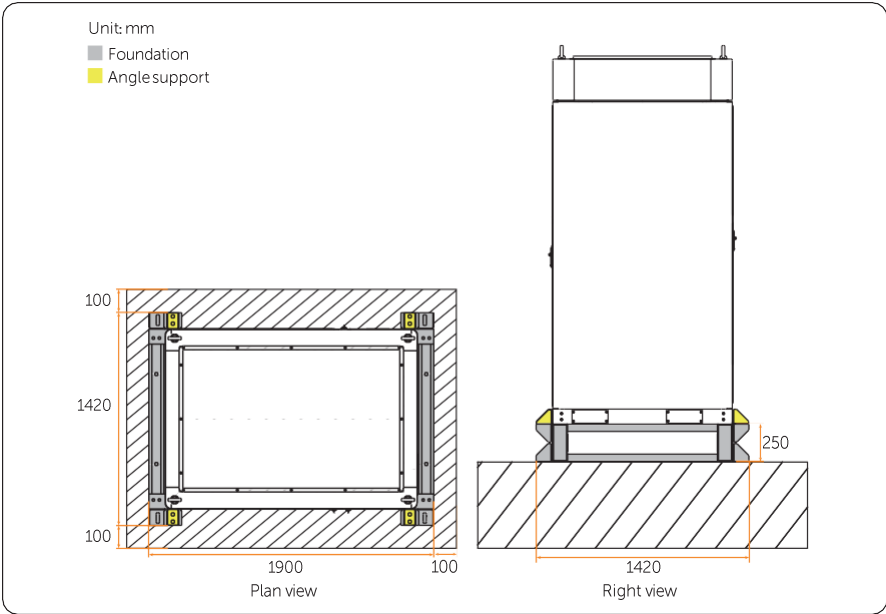

Figure 4-7 Angle supports at front and rear sides

## Preparation before Installation

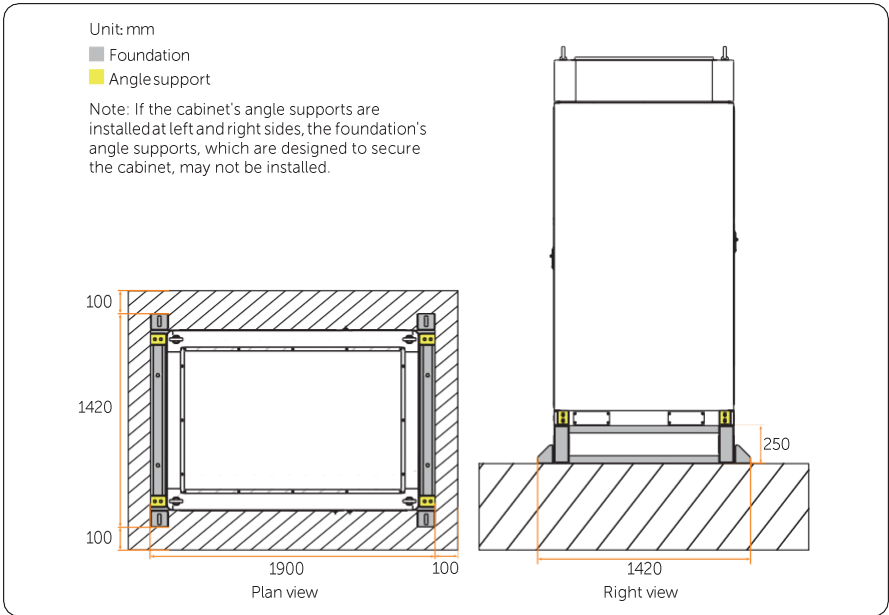

Figure 4-8 Angle supports at left and right sides

### NOTICE!

After completing construction of the steel foundation, please strictly comply with the following steps:

- Install the bottom angle support first to secure the foundation to the ground;
- Install the top angle support (if any);
- Finally, install the cabinet onto the steel foundation.

After the steel foundation is finished, the installation procedure for cabinet can be referred to "6.4 Installation Procedure for Angle Support and Cover".

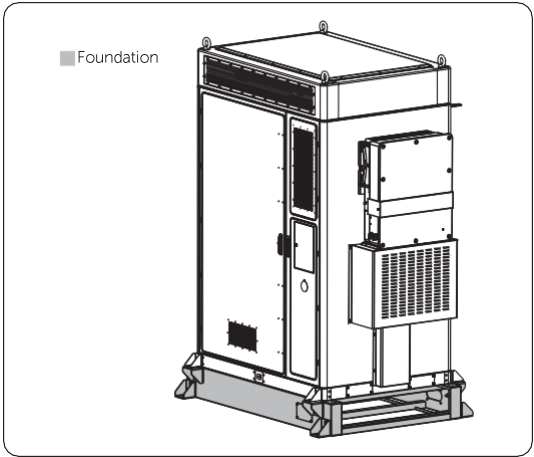

Figure 4-9 Final installation diagram

### 4.1.2 Clearance Requirement

This device has multiple installation methods:

- Single cabinet (see Figure 4-5)
- Multiple cabinets (see Figure 4-6 and Figure 4-7)

In order to ensure the heat dissipation of the inverter and facilitate disassembly, the minimum space to be reserved around the cabinet must meet the following standards.

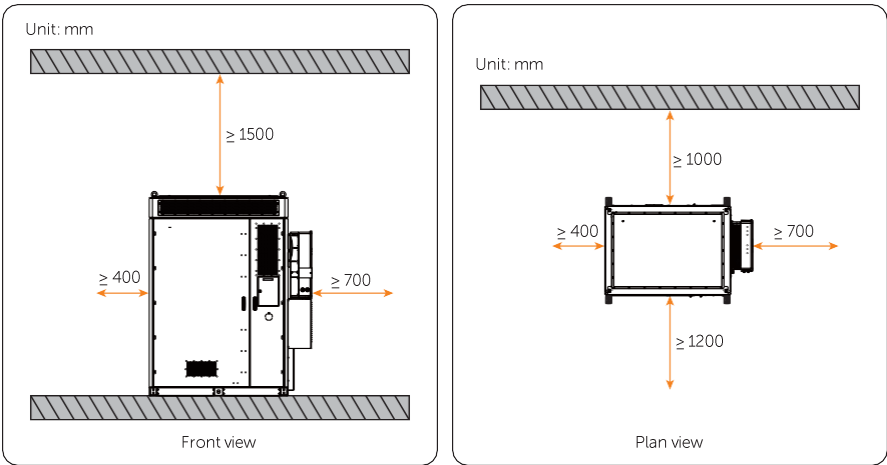

Figure 4-10 Single cabinet

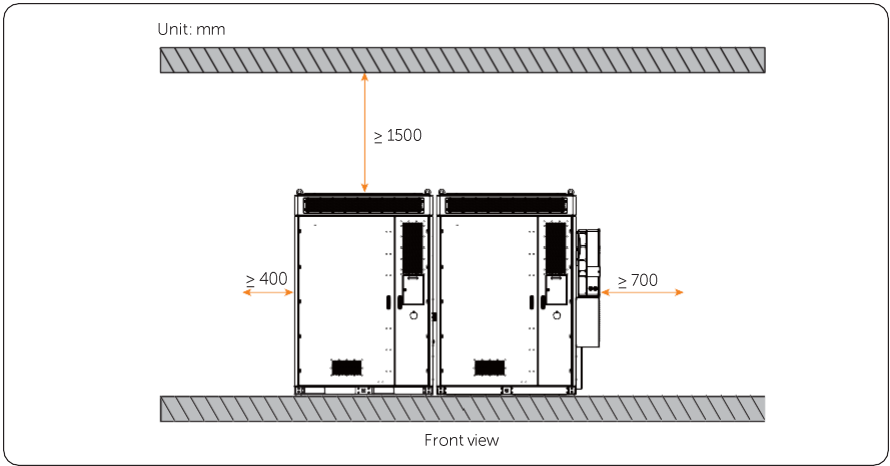

Figure 4-11 2 and more cabinets

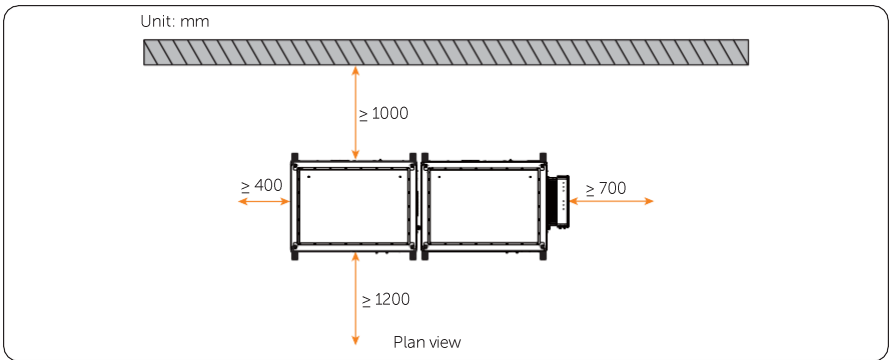

Figure 4-12 2 and more cabinets

## 4.2 Tools Requirement

Installation tools include but are not limited to the following recommended ones. If necessary, use other auxiliary tools on site.

 Hammer drill (Ø18 mm)	 Multimeter (≥ 1500 V DC)	 Measuring tape	 Utility knife
 Marker	 Torque wrench (M4~M12)	 Torque screwdriver (Flat-head: M2, M3, M10) (Phillips head: M2.5, M3, M4, M5, M6)	 Rubber mallet
 Wire stripper	 Crimping tool for RJ45	 Hydraulic wire crimper	 Diagonal pliers
 Crimping tool for PV terminals	 Crimping tool for ferrules	 Wire cutter	 Crimping tool
 Heat gun	 Heat shrink tubing (Ø13, Ø30~60 mm)	 Cable tie	 Steel pipe Ø25~30 mm
 Insulated ladder	 Spirit level	 Vacuum cleaner	 Electric forklift

# Preparation before Installation

---

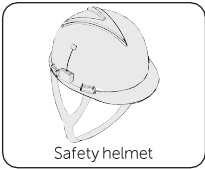
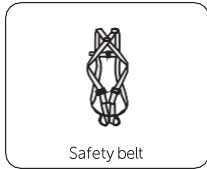
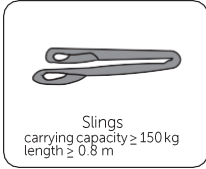
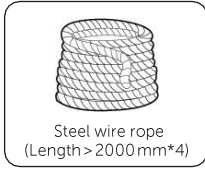
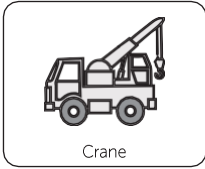

### 4.3 Additionally Required Materials

Table 4-2 Additionally required wires







No.	Required Material	Type	Conductor Cross-section
1	PV cable	 Dedicated PV cable with a voltage rating of 1000 V, a temperature resistance of 105°C, a fire resistance grade of VW-1	6 mm <sup>2</sup>
2	Communication wire 1	 Network cable CAT5E	/
3	Communication wire 2	 Four-core signal cable	0.25 mm <sup>2</sup> -0.3 mm <sup>2</sup>
4	Grounding plate	 Galvanized iron plate	Width: 40 mm Depth: 4mm
5	Grid wire	 Five-core copper cable * The conductor cross-section of copper cables connecting to the distribution box (a total of 4 copper cables) is 35 mm <sup>2</sup> , as well as 16 mm <sup>2</sup> for a copper cable that is connected to the grounding.	35 mm <sup>2</sup> * 4 + 16 mm <sup>2</sup> * 1
6	EPS wire	 Four-core copper cable * The conductor cross-section of copper cables connecting to the cabinet (a total of 4 copper cables) is 35 mm <sup>2</sup> .	35 mm <sup>2</sup> * 4
8	Additional PE wire	 Conventional yellow and green wire	> 25 mm <sup>2</sup>

Table 4-3 Additionally required materials

No.	Required Material	Type
1	Ring terminal	 TLK16-8 ring terminal

# 5 Unpacking and Inspection

## 5.1 Battery Cabinet Unpacking

### 5.1.1 Unpacking

- The device undergoes 100% testing and inspection before shipping from the manufacturing facility. However, transport damage may still occur. Before unpacking the rechargeable battery, please verify that the model and outer packing materials for damage, such as holes and cracks.
- Due to the cabinet height exceeding 2m, please take necessary precautions for working at heights when removing the outer packaging. The unpacking procedure can be referred to the following Figure.

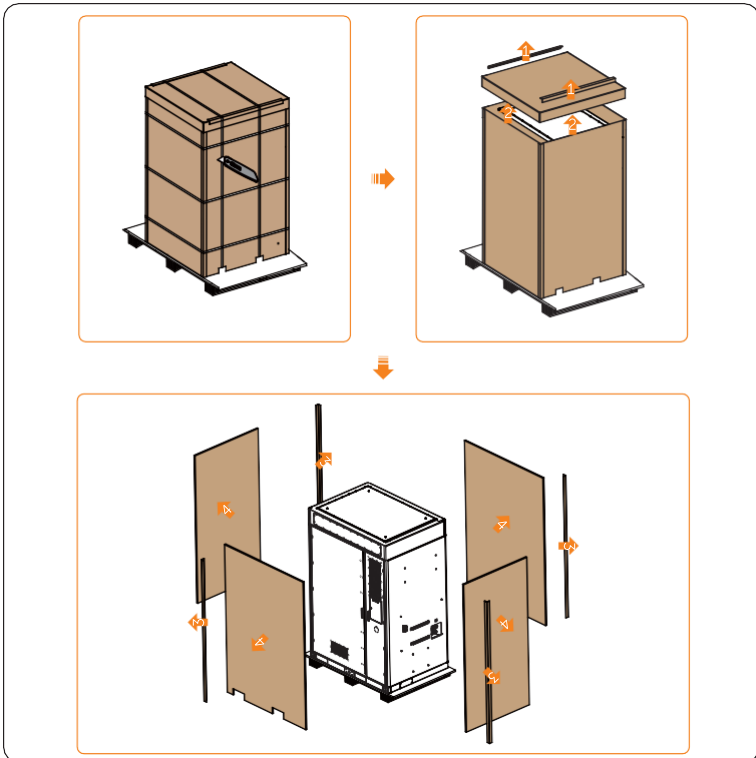

Figure 5-1 Unpacking

- When unpacking, please handle all packaging materials properly for future storage or relocation of this device.
- After unpacking, please check if the device is intact and if all accessories are complete. If there is any damage or missing accessories, please contact your dealer immediately for assistance.

### 5.1.2 Packing List

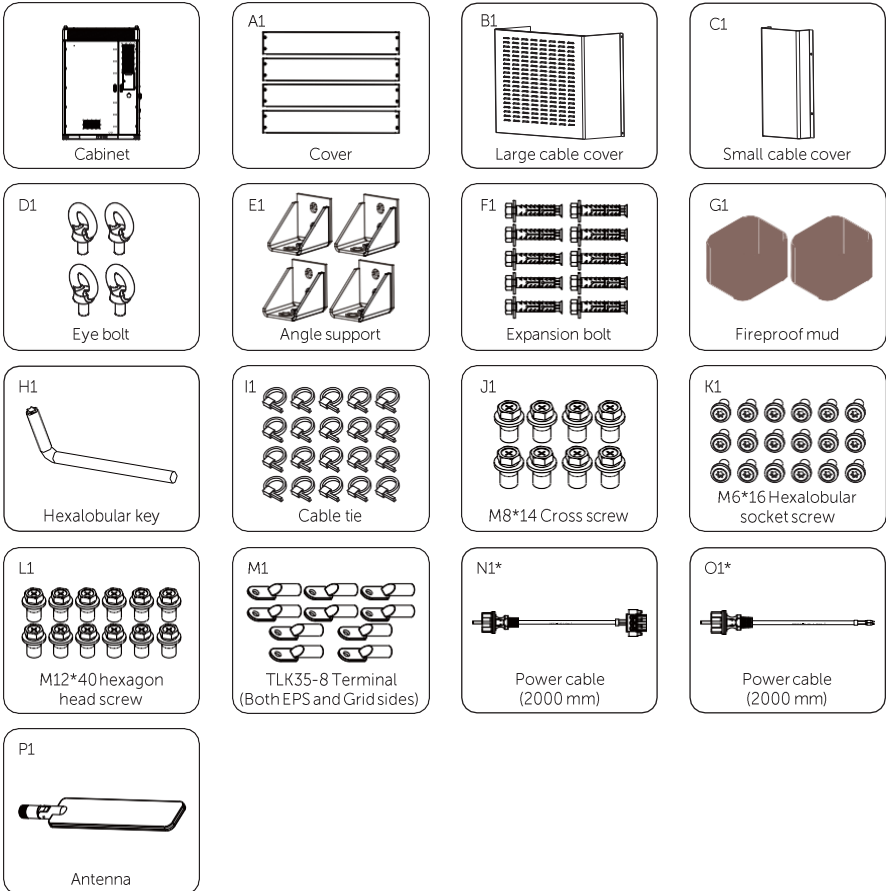

Table 5-1 Packing list

Item	Description	Quantity
/	Cabinet	1 pc
A1	Cover	4 pcs
B1	Large cable cover	1 pc
C1	Small cable cover	1 pc
D1	Eye bolt	4 pcs
E1	Angle support	4 pcs
F1	Expansion bolt	10 pcs
G1	Fireproof mud	2 pcs
H1	Hexalobular key	1 pc
I1	Cable tie	20 pcs
J1	M8*14 Cross screw	8 pcs
K1	M6*16 Hexalobular socket screw	18 pcs
L1	M12*40 hexagon head screw	12 pcs
M1	TLK35-8 Terminal (Both EPS and Grid sides)	10 pcs
N1*	Power cable (2000 mm)	1 pc
O1*	Power cable (2000 mm)	1 pc
P1	Antenna	1 pc

**NOTICE!**

- The mark "\*" indicates that if one of the cables connecting the high-voltage box AC input and AC power is damaged, the N1 power cable (2000 mm) can be used as a replacement cable to connect to the AC input and the O1 power cable (2000 mm) can be used as a replacement cable to connect to the AC power.

## 5.2 Inverter Unpacking

### 5.2.1 Unpacking

- The inverter undergoes 100% testing and inspection before shipping from the manufacturing facility. However, transport damage may still occur. Before unpacking the inverter, please check the outer packing materials for damage, such as holes and cracks.
- Unpacking the inverter according to the following figure.

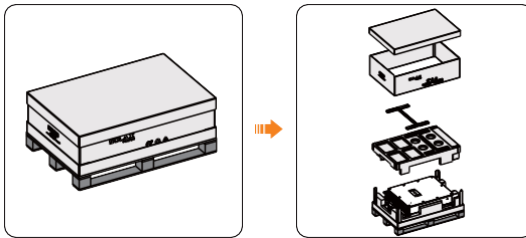

Figure 5-2 Unpacking the inverter

- Be careful when dealing with all package materials which may be reused for storage and relocation of the inverter in the future.
- Upon opening the package, check whether the appearance of the inverter is damaged or lack of accessories. If any damage is found or any parts are missing, contact your dealer immediately.

5.2.2 Packing List



\* Refer to the actual delivery for the optional accessories.

Table 5-2 Packing list

Item	Description	Quantity
/	Inverter	1 pc

Item	Description	Quantity
A2	Mounting bracket	1 pc
B2	M5*50 screw	4 pcs
C2	Cable clamp	1 pc
D2	OT terminal	1 pc
E2	RJ45 terminal	7 pcs
F2	8-pin terminal block	2 pcs
G2	Positive battery connector	2 pcs
H2	Negative battery connector	2 pcs
I2	Positive PV connector & pin contact	10 pairs for X3-AELIO-50K 12 pairs for X3-AELIO-60K
J2	Negative PV connector & pin contact	10 pairs for X3-AELIO-50K 12 pairs for X3-AELIO-60K
K2	M10*100 expansion bolt	4 pcs
L2	Eye bolt	2 pcs
M2	Removal tool for PV connectors	1 pc
N2	AC terminal	10 pcs
O2	AC connector	1 pc
P2	Five-hole sealing plug	2 pcs
Q2	M6 screw	10 pcs
R2	M4*12 screw	2 pcs
S2	Negative PV dustproof buckle	12 pcs
T2	Positive PV dustproof buckle	12 pcs
U2	M4*10 screws	2 pcs
V2	Inverter screen cover	1 pc
W2	RJ45 connector	1 pc
X2	CT	1 pc
Y2	Documents	/
/	Meter (optional)	1 pc
/	Dongle (optional)	1 pc

# 6 Mechanical Installation

---

After determining the installation site, please take out the required underground cables.

## WARNING!

- Avoid installing, operating and maintaining the device or cables outdoors under severe weather conditions such as lightning, rain or snow.
- The device must be installed by professionals in accordance with local regulations and standards.
- Use insulated tools and wear personal protective equipment (PPE) during installation and maintenance.
- Do not destroy the cabinet's anti-corrosion coating during the process of installation.
- Before drilling, please check and ensure that the area is free of pipes, light switches, sockets, and wires, and safe to drill into.
- Please take steps to cover the device to prevent debris from entering it while drilling holes.
- After drilling, clean up the site in time.

## CAUTION!

- Pay attention to the weight of the equipment at all times during transportation and installation, improper lifting or dropping of the equipment may cause personal injury.

## 6.1 Battery Cabinet Installation Dimensions

Angle supports installed at front and rear sides

Unit: mm

- Installation position for eye bolt
- Fork hole
- Angle support
- Foundation

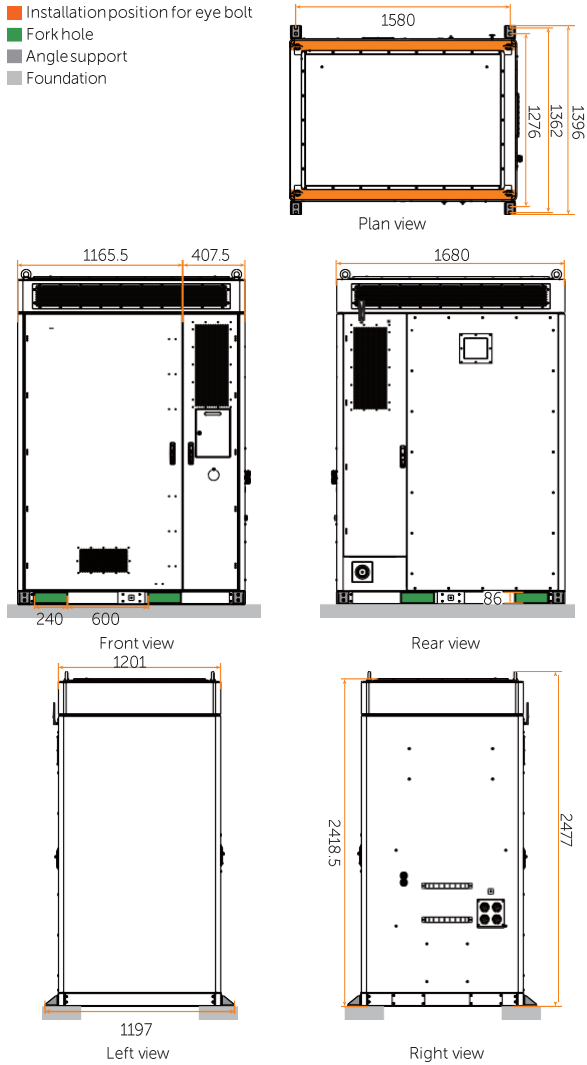





Figure 6-1 Dimension of battery cabinet

Angle supports installed at left and right sides

Unit: mm

-  Installation position for eye bolt
-  Fork hole
-  Angle support
-  Foundation

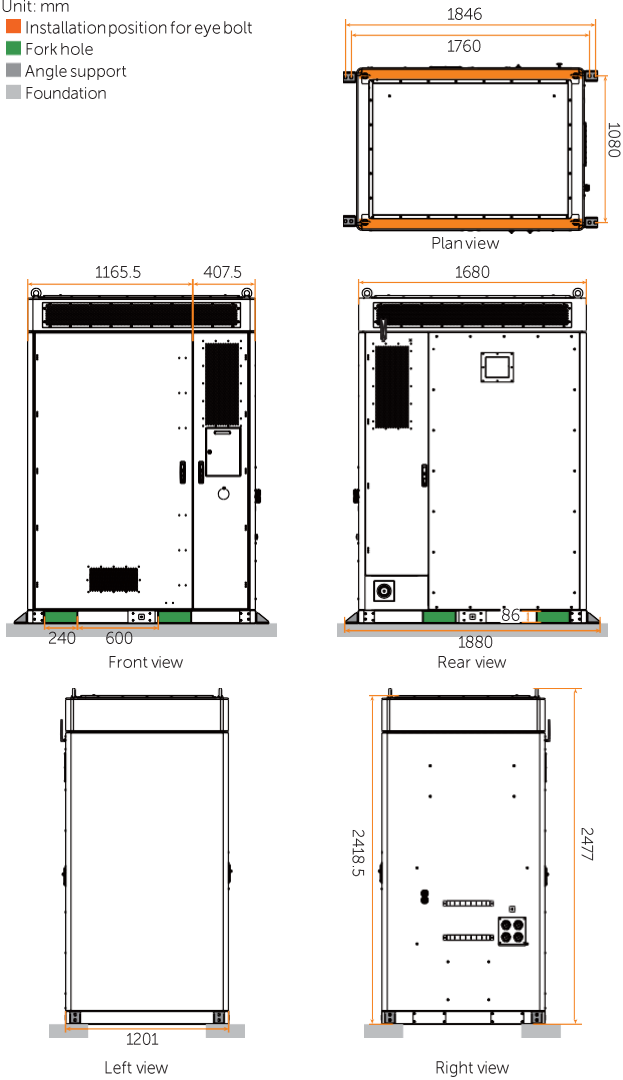

Figure 6-2 Dimension of battery cabinet

## 6.2 Battery Cabinet Handling

### NOTICE!

- There are two ways to move a cabinet: using a crane or a forklift. Please refer to “3.1.1 Battery Cabinet Transportation” for related handling precautions.

### 6.2.1 Hoisting

### NOTICE!

#### When hoisting:

- Temporary warning signs or fences should be set up in the hoisting area, and only the qualified persons can access it.
- Never stand and walk under or near the device being lifted or lowered.
- For safety reasons, avoid long-distance hoisting operations.
- Please be careful when hoisting and placing the device, and do not remove the ropes before it is seated on the foundation. Please make sure that the boom lift moves level and the cabinet's tilt angle is  $\leq 5^\circ$  during hoisting.
- The angle in both the diagonal ropes shall be  $\leq 60^\circ$ .
- Do not lift the next one before the previous cabinet has been installed on the foundation.

#### Installation of eye bolt

**Step 1:** Remove the M20 screws (with a total of 4 pieces) inside the top eye bolt holes using a torque wrench.

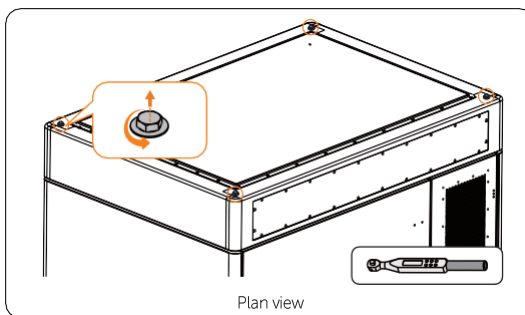

Figure 6-3 Unscrewing M20 screws

**Step 2:** Insert and clockwise the eye bolts (M20) (Part D1) (with a total of 4 pieces).

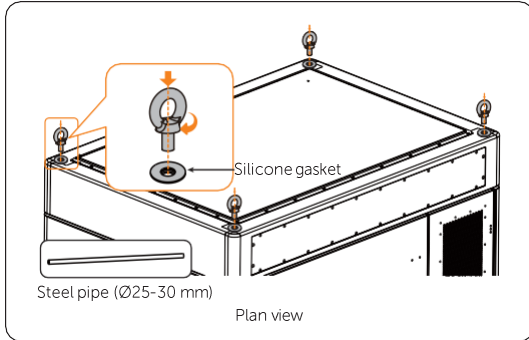

Figure 6-4 Tightening eye bolts

**NOTICE!**

- Put the silicone gaskets in place before inserting the eye bolts.
- Please ensure that the eye bolt's shoulder makes total contact with the silicone gasket.

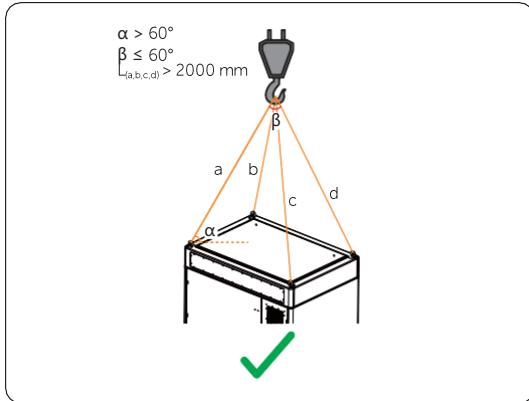

Figure 6-5 Proper way of hoisting

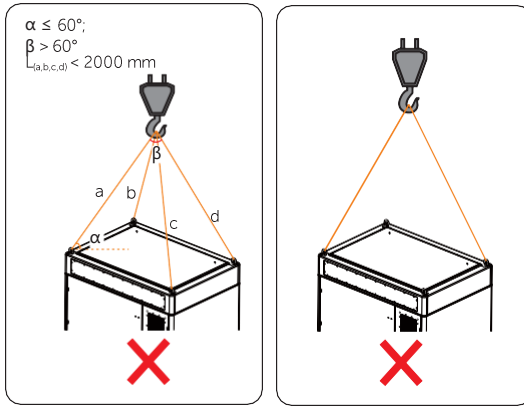

Figure 6-6 Improper way of hoisting

**NOTICE!**

- Before lifting, please prepare sufficient length of lifting ropes according to the actual situation.
- L=Length

### 6.2.2 Forklift

**NOTICE!**

- When using a forklift to move the cabinet, please secure it according to the actual situation to ensure that the cabinet does not pose a risk of tipping over.

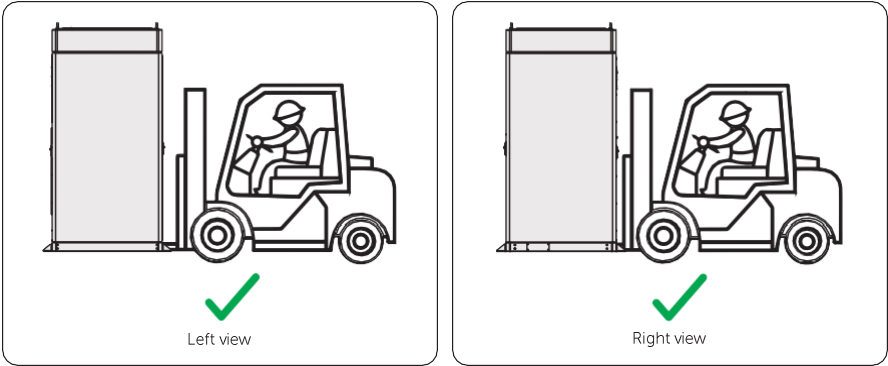

Figure 6-7 Right positions

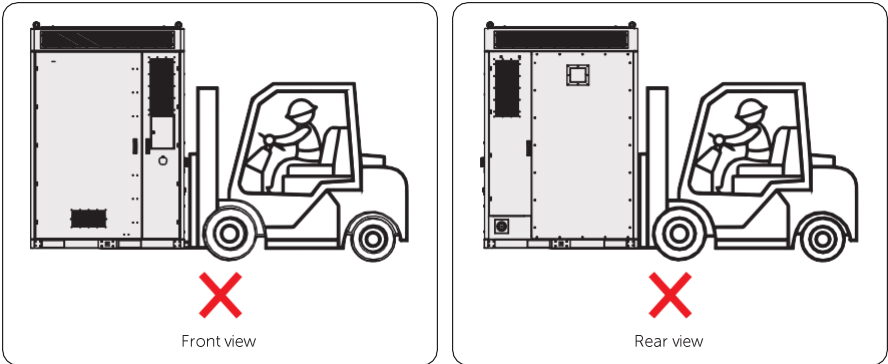

Figure 6-8 Wrong positions

**NOTICE!**

- For installation space requirements, please refer to "6.1 Battery Cabinet Installation Dimensions".
- For foundation requirements, please refer to "4.1.1 Installation Foundation Requirements".

### 6.3 Installation Procedure for Angle Support and Cover

The cabinet allows the angle supports to be installed at the front and-rear sides or at the left and-right sides. Since the installation procedure for the angle support is the same, take the angle support installed at the front and-rear sides, for instance.

**Step 1:** After determining the installation position of the cabinet, align the holes on the angle support (Part E1) with the holes on the cabinet, and draw a circle on the bottom of the angle support. There are totalling 4 angle supports for a cabinet.

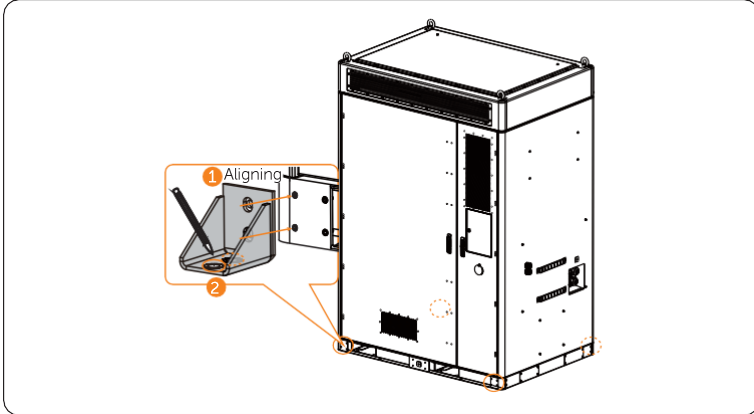

Figure 6-9 Marking hole position

**Step 2:** Drill holes at the previously marked positions (drill bit:  $\text{Ø}18\text{ mm}$ ; hole depth:  $95\sim 105\text{ mm}$ ). After drilling, clean the foundation surface with a vacuum cleaner.

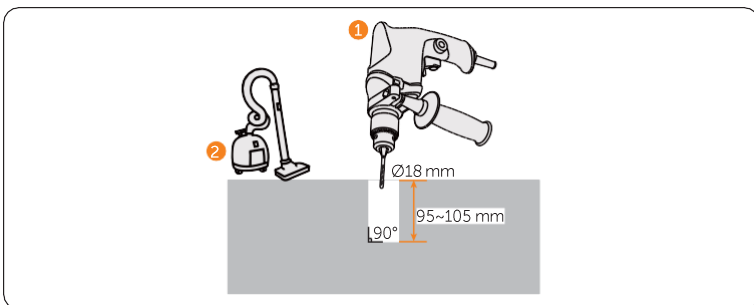

Figure 6-10 Drilling

**Step 3:** Attach the angle supports to the cabinet and ensure that holes are aligned, and insert M12 screws (Part L1) and tighten them clockwise using a torque wrench (torque:  $42\pm 4.2\text{ N}\cdot\text{m}$ ). Each angle support has two M12 screws, with a total of eight M12 screws.

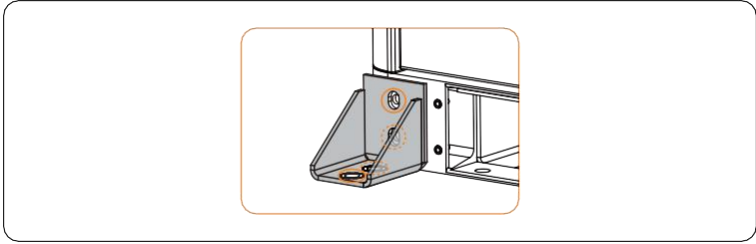

Figure 6-11 Aligning screw holes

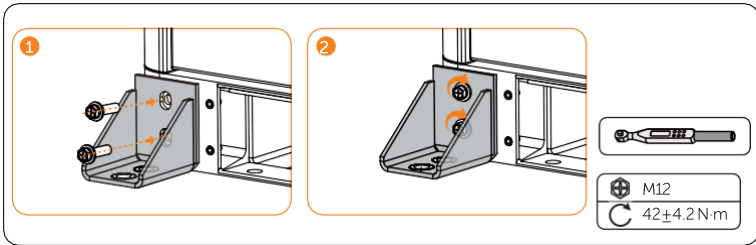

Figure 6-12 Tightening M12 screws

**NOTICE!**

- Reinstall the angle supports, ensuring that the screw holes on the angle support align with the screw holes on the cabinet and foundation.

**Step 4:** Use a rubber hammer to drive the expansion bolts (Part F1) into the foundation screw holes, and then tighten them clockwise with a torque wrench (M12) (torque:  $42 \pm 4.2$  N·m). Each angle support has 2 expansion bolts, with a total of 8 expansion bolts.

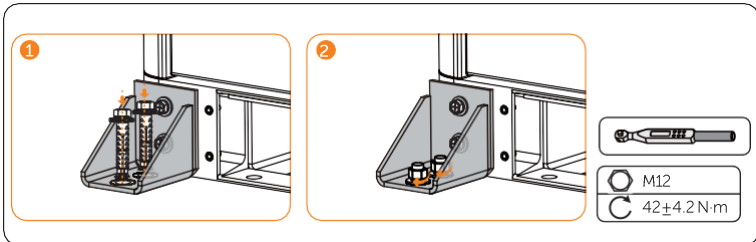

Figure 6-13 Tightening expansion bolts

**Step 5:** After the angle supports have been installed, take out the covers (Part A1) to seal the forklift hole and tighten the M6 hexalobular screws (Part K1) with the hexalobular key (Part H1). Each cover has 4 screws, with a total of 4 covers.

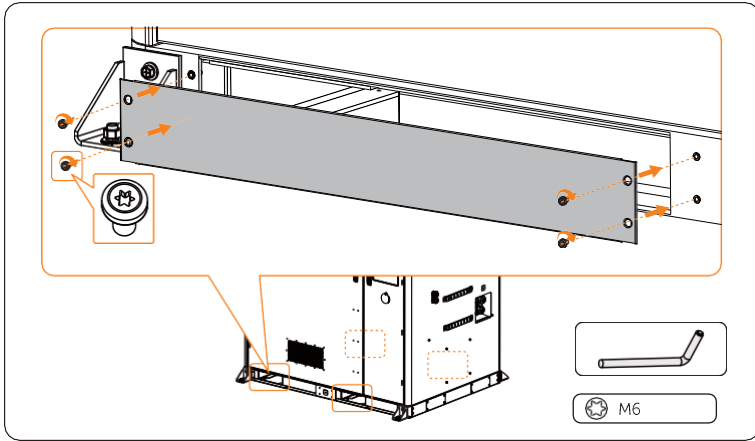

Figure 6-14 Fixed covers

## NOTICE!

- The above-mentioned installation steps also apply to the angle supports, which are installed on both the left and right sides.

## 6.4 Antenna Installation

## NOTICE!

- The user can decide whether the reserved port connects an antenna based on the actual situation.
- Regarding the other antenna port, the antenna is delivered with the accessories kit.

There are two antenna ports on the rear side of the cabinet. The left one shall be connected to an antenna, and the right one is a reserved port. Regarding the antenna installation steps, please do as follows.

**Step 1:** Remove the silicone cap.

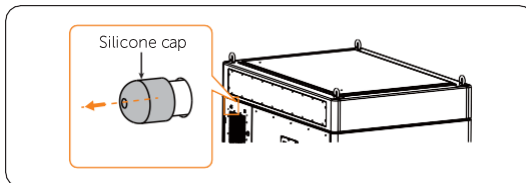

Figure 6-15 Removing silicone cap

**Step 2:** Correctly insert and tighten the antenna (Part P1) by turning it clockwise.

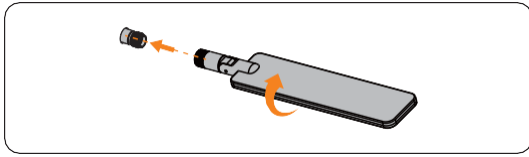

Figure 6-16 Installing antenna

**Step 3:** Fold the antenna up 90°.

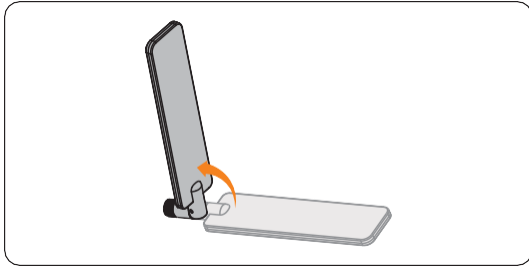

Figure 6-17 Folding the antenna

After installing the antenna, see following figure.

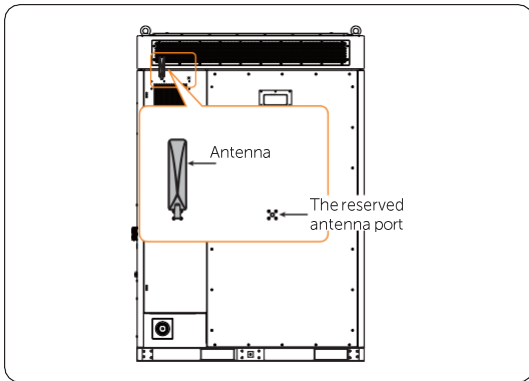

Figure 6-18 Installing an antenna

## 6.5 Inverter Installation

### WARNING!

- Only the qualified personnel can perform the mechanical installation following the local standards and requirements.

### CAUTION!

- Always be aware of the weight of the inverter. Personal injuries may result if the inverter is lifted improperly or dropped while being transported or mounted.
- Use insulated tools when installing the inverter. Personal protective equipment must be worn during installation and maintenance.

### NOTICE!

- Install the inverter at a maximum back tilt of 5 degrees and avoid forward tilted, side tilted, or upside down.

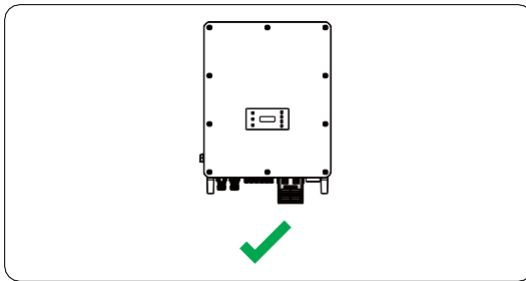

Figure 6-19 Correct installation

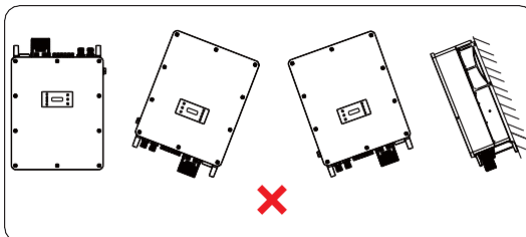

Figure 6-20 Incorrect installation

### 6.5.1 Inverter Installation Dimensions

Check the dimensions of the wall mounting bracket before mounting and reserve sufficient space for heat dissipation and installation of the whole system.

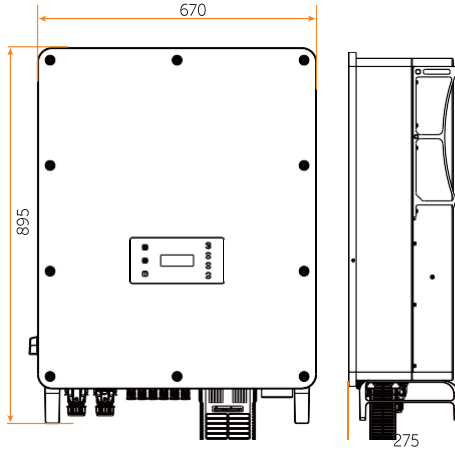

Figure 6-21 Dimensions (Unit: mm)

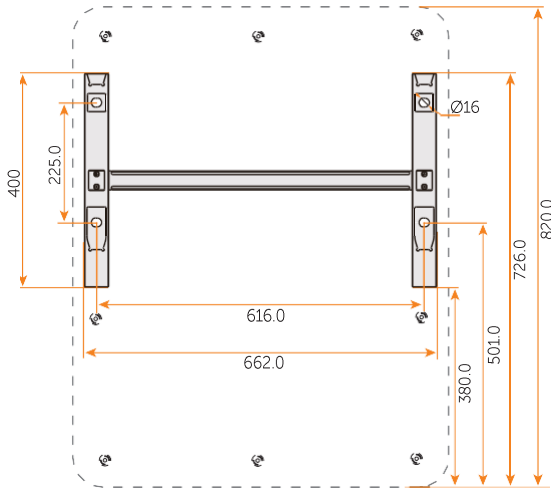

Figure 6-22 Dimensions 2 (Unit: mm)

## 6.5.2 Installation Procedures

**Step 1:** Confirm the four holes for the position of the mounting bracket on the battery cabinet.

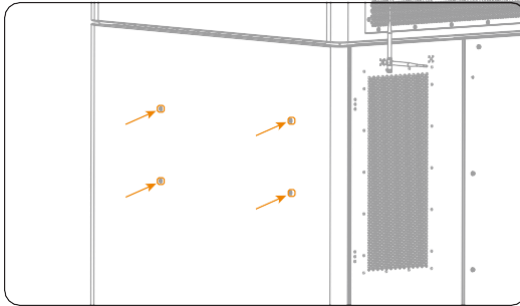

Figure 6-23 Confirming the position of the mounting bracket

**Step 2:** Take out the mounting bracket (Part A2) from the carton. Attach the mounting bracket on the battery cabinet. Knock the expansion screws (Part E1) into the holes and secure it to the cabinet by torque wrench. (Torque: 24 N·m)

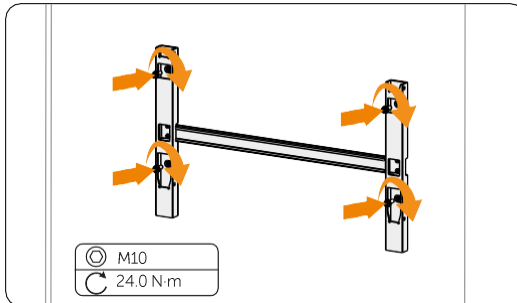

Figure 6-24 Securing the mounting bracket

**Step 3:** Open the anti-static bag and take out the machine.

### NOTICE!

- If the inverter is temporarily needed to be placed on the ground, use foam or other protective materials to prevent any damage to the inverter.

**Step 4:** Remove the carton, loosen and pull out the M10 screws on the sides of the inverter with a flat-head screwdriver. Tighten the two eye bolts (Part L2) on the two sides of the inverter and tie them with a sling. Lift up the inverter with a crane and hang the device on the mounting bracket. The keyways of the inverter must be hooked into the buckles of the mounting bracket.

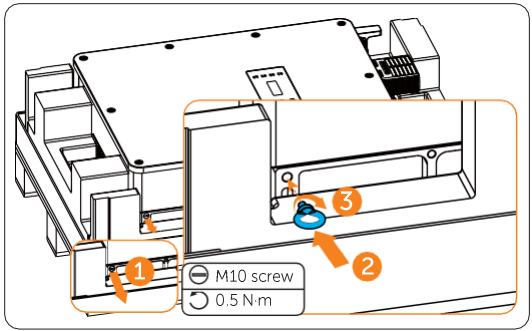

Figure 6-25 Installing the eye bolts

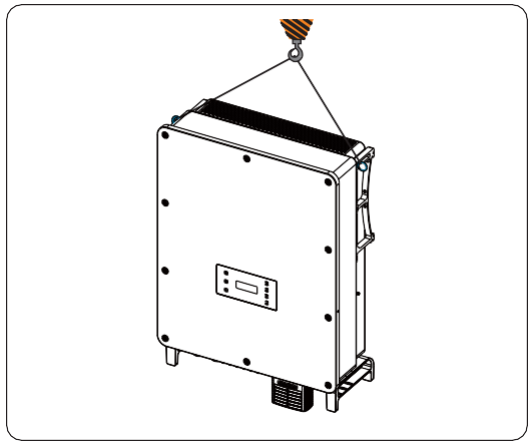

Figure 6-26 Hanging the inverter

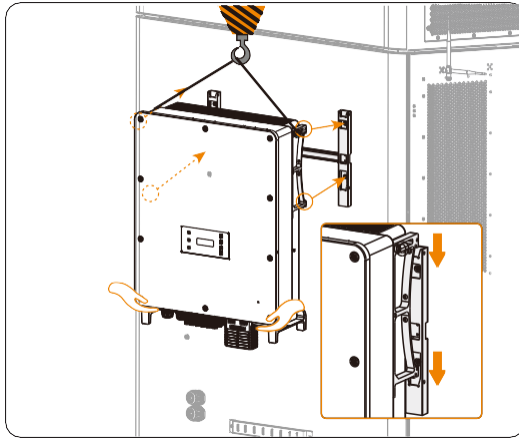

Figure 6-27 Hooking the inverter on the bracket

**NOTICE!**

- When the inverter is lifted up from the carton or the inverter is close to the mounting bracket, use hands to adjust the inverter position to prevent any damage to the inverter.
- Ladders will be helpful for installers to stand in a proper position and adjust the inverter position.

**Step 5:** Remove the eye bolts when the inverter is hooked on the mounting bracket and tighten the M10 screws with a flat-head screwdriver.

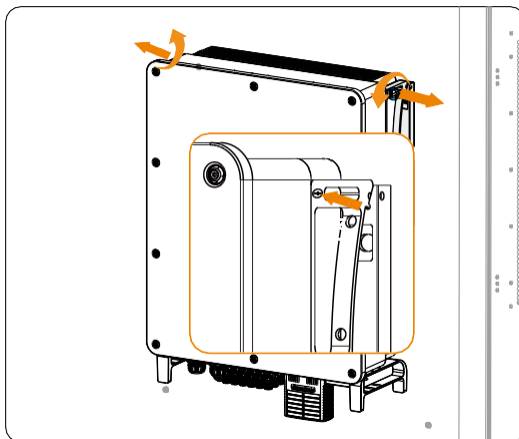

Figure 6-28 Removing the eye bolts

NOTICE!

- After removing the eye bolts from the inverter, keep them in a safe place. They are needed when the inverter is relocated or disassembled.

**Step 6:** Secure the inverter to the mounting bracket with M5\*50 screws (Part B2). (Torque:  $2 \pm 0.2$  N·m)

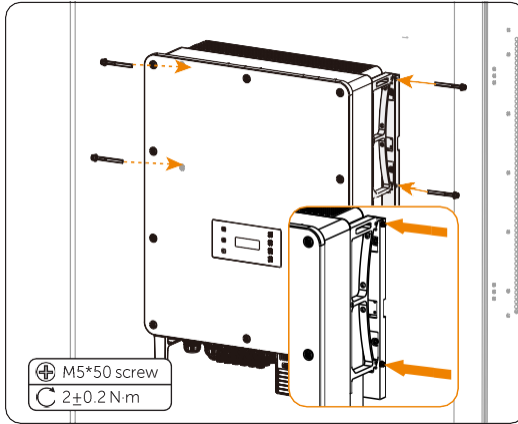

Figure 6-29 Securing the inverter

# 7 Electrical Connection

**NOTICE!**

- Before wiring, operators are required to learn which parts need to be conducted wiring. For details, please refer to Figure 7-1.

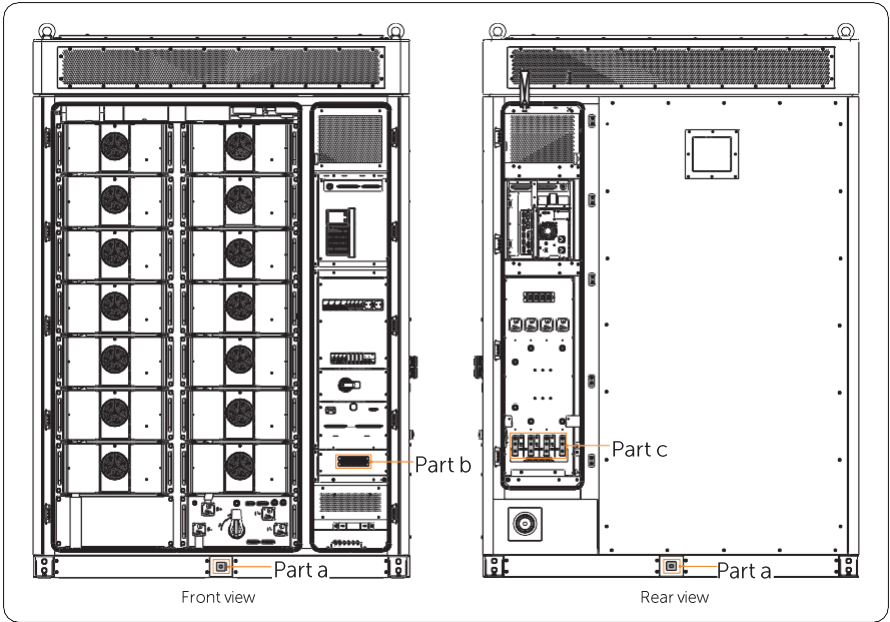

Figure 7-1 Part that needs wiring

## 7.1 Cabinet Grounding Connection

The device supports grounding plate connection and PE connection. Regarding the wiring area, see **Part a** in “Figure 7-1 Part that needs wiring”, please strictly follow the steps below.

### NOTICE!

- There are two GND ports on the cabinet. Either of them can be connected.
- The grounding plate or the PE wire is prepared by the user self. For details, please refer to “4.3 Additionally Required Materials”.

### Grounding Plate Connection

**Step 1:** Insert and tighten M12 screw (Part L1) to secure grounding plate (torque:  $42 \pm 2$  N·m).

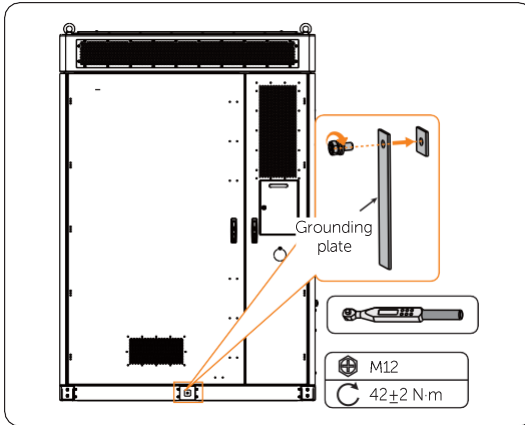

Figure 7-2 Tightening M12 screws

## PE Connection

**Step 1:** Strip the cable jacket about 20 mm from the end.

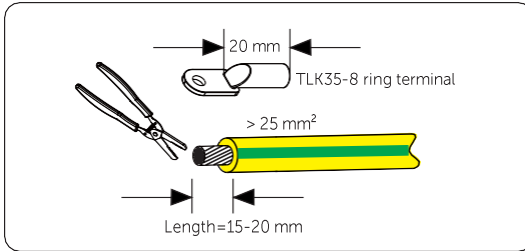

Figure 7-3 Stripping cable jacket

**Step 2:** Cut the heat-shrink tubing ( $\text{Ø}15\text{-}20 \text{ mm}$ ) to about a length of 30 mm to 40 mm, carefully slide it onto the end of the cable, and then carefully slip the wires all the way into the grounding terminal.

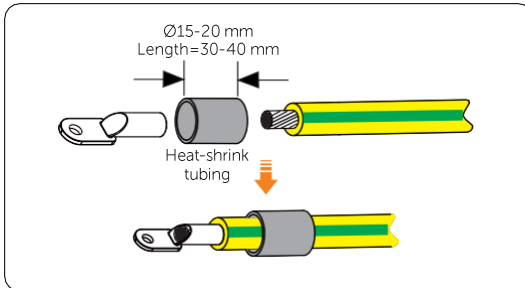

Figure 7-4 Cutting heat-shrink tubing

**Step 3:** Crimp the terminal, and heat the heat-shrink tubing after it wraps the end of terminal.

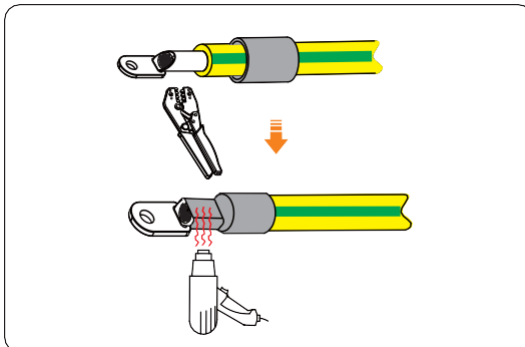

Figure 7-5 Crimping and heating

**Step 4:** Connect the assembled grounding cable to the grounding port of the cabinet, and then tighten M12 screw (Part L1) (torque:  $42 \pm 2$  N·m).

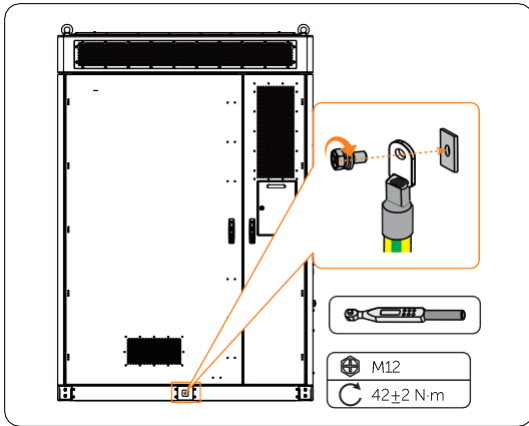

Figure 7-6 Tightening M12 screw

## 7.2 Inverter Electrical Connection

### DANGER!

- Before electrical connection, make sure the DC switches and AC breakers are disconnected. Otherwise, electrical shock may be caused by high voltage, resulting in serious personal injury or death.

### WARNING!

- Only the qualified personnel can perform the electrical connection following the local standards and requirements.
- Follow this manual or other related document to wire connection. The inverter damage caused by incorrect cabling is not in the scope of warranty.
- Use insulated tools and wear personal protective equipment throughout the electrical connection process.

### NOTICE!

- The PE cable, Grid cable, EPS cable, battery cables, COM1 communication cables of the inverter are prefabricated in the battery cabinet, the cable outlets as shown below:

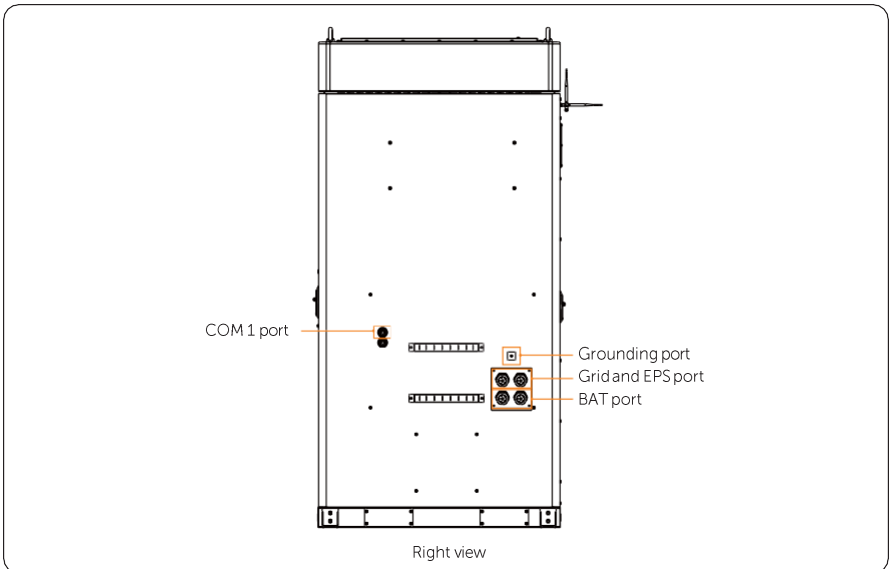

Figure 7-7 Prefabricated inverter cables in battery cabinet

7.2.1 Terminals of Inverter

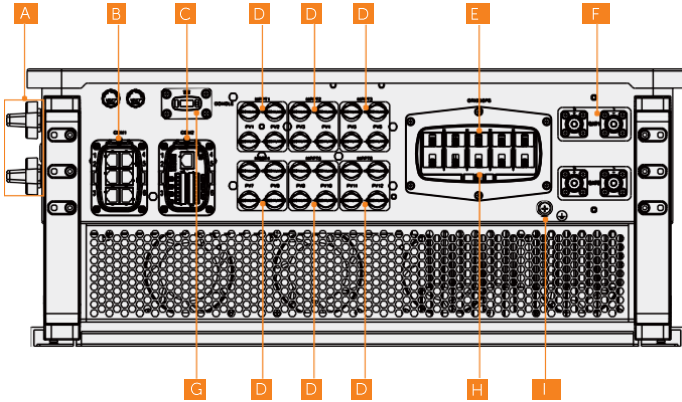



Figure 7-8 Terminals of Inverter

Table 7-1 Description of terminals

Item	Description	Decisive voltage class
A	DC switch (including DC switch 1 and DC switch 2)	-
B	COM 1 communication terminal (including Parallel-1, Parallel-2, BMS-1, BMS-2, RS485, DRM)	DVC-A
C	COM 2 communication terminal (including Ripple control, DIO, Meter/CT)	DVC-A
D	PV connection terminal (PV1~PV5 terminals for X3-AELIO-50K; PV1~PV6 terminals for X3-AELIO-60K)	DVC-C
E	EPS connection terminal	DVC-C
F	Battery connection terminal (including BAT 1 and BAT 2)	DVC-C
G	Dongle terminal	DVC-A
H	Grid connection terminal	DVC-C
I	Ground connection point	-

## 7.2.2 Inverter Grounding Connection

All non-current carrying metal parts of the device and other enclosures in the PV system must be grounded reliably. The PE point at the AC output terminal is used only as a PE equipotential point, not a substitute for the PE point on the enclosure. The connection point has been labeled with the following label: .

### CAUTION!

- In compliance with IEC62109-2, X3-AELIO series inverter has the grounding detection function which is used to check whether the inverter is properly grounded before it starts. If the inverter is not connected with earth, the inverter will turn on a red light and report **Earth Relay Fault**.

### PE connection procedures

#### NOTICE!

The PE cable of the inverter outlets from the **Grounding port** in "Figure 7-7 Prefabricated inverter cables in battery cabinet", please strictly follow the steps below.

**Step 1:** Loosen the PE screw on the inverter with a cross screwdriver.

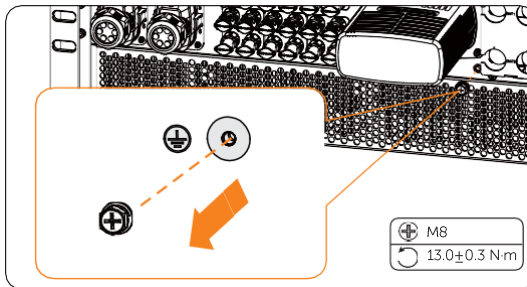

Figure 7-9 Uninstalling the screw

**Step 2:** Connect the PE cable to the inverter and secure it with the original screw. (Torque:  $13.0 \pm 0.3$  N·m)

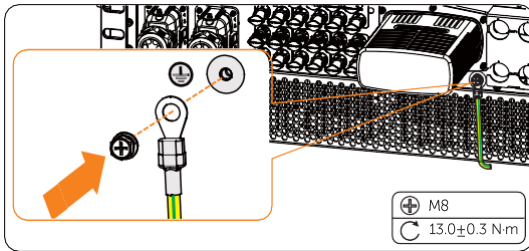

Figure 7-10 Securing the PE cable

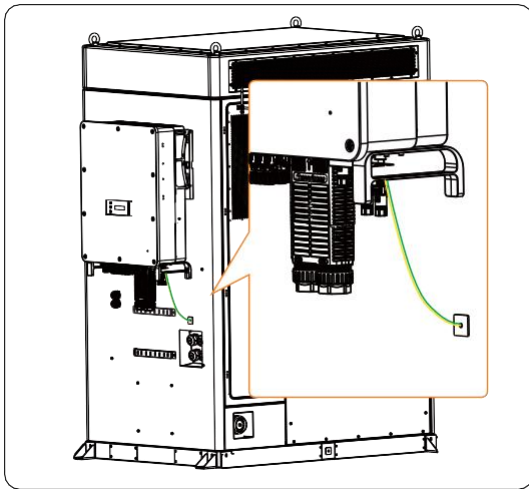

Figure 7-11 Well connected PE cable

### 7.2.3 AC Connection

#### NOTICE!

- Before connecting the inverter to the grid, approval must be received by local utility as required by national and state interconnection regulations.

The inverter has an EPS function. When the grid is connected, the inverter outputs go through the Grid terminal, and when the grid is disconnected, the inverter outputs go through the EPS terminal.

#### Requirements for AC connection

- Grid voltage requirement
  - » The grid voltage must be within the permissible range. The inverter is suitable for rated voltage 400V/230V, 380/220V, frequency 50/60Hz. Other technical requests should comply with the requirement of the local public grid.
- RCD requirement
  - » The inverter does not require an external residual-current device when operating. If an external RCD is required by local regulations, it is recommended to use a Type-A RCD with the value of 300 mA. When required by local regulations, the use of an RCD type B is permitted.
- AC breaker requirement
  - » An AC breaker that matches the power of the inverter must be connected between the inverter output and the power grid, and each inverter must be equipped with an independent breaker or other load disconnection unit to ensure the safe disconnection from the grid. Refer to “[4.3 Additionally Required Materials](#)” for specific data of AC breaker of Grid and EPS.
- Load requirement
  - » It is prohibited to connect any load between inverter and AC switch that directly connects to the inverter.
- EPS load requirement
  - » Do not connect sensitive precision instruments or medical device to the EPS terminal.
  - » Ensure that the EPS load rated power is within the EPS rated output power range. Otherwise, the inverter will report an **Overload Fault** warning. When **Overload Fault** occurs, turn off some loads to make sure it is within the EPS rated output power range, and the inverter will return to normal after **ESC** key on the LCD screen pressed.
  - » For inductive load such as fridge, air conditioner, washing machine, etc., ensure that the start power does not exceed the EPS peak power.

Table 7-2 EPS load information

Type of load	Device	Start power
Resistive load	Lamp	Equal to rated power
	Fan	Equal to rated power
	Hairdryer	Equal to rated power
Inductive load	Fridge	3-5 times rated power
	Air conditioner	3-6 times rated power
	Washing machine	3-5 times rated power
	Microwave oven	3-5 times rated power

\* Please refer to the nominal current of the device for the actual start current.

Wiring procedures

NOTICE!

The Grid and EPS cables of the inverter outlet from the **Grid and EPS port** in “Figure 7-7 Prefabricated inverter cables in battery cabinet”, please strictly follow the steps below.

**Step 1:** Anti-clockwise loosen the swivel nut and pull out the sealing plugs to disassemble the AC connector (Part O2) as below. Keep the sealing plugs still in the cable support sleeve if you choose not to connect the cable. Replace the original sealing plugs with the five-hole sealing plugs (Part P2).

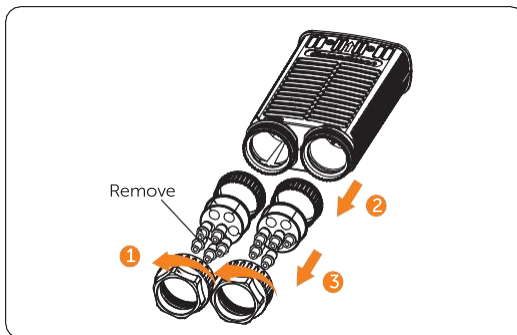

Figure 7-12 Disassembling the AC connector

**Step 2:** Thread the Grid and EPS cable through the AC connector.

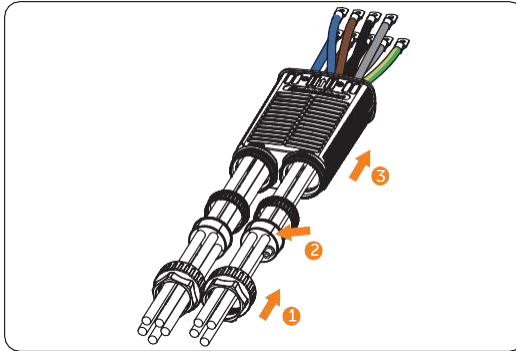

Figure 7-13 Threading cables through the AC connector

**Step 3:** Secure the L1, L2, L3, N and grounding conductors of the assembled Grid cable with M6 screws. (Torque:  $5.0 \pm 1$  N·m) Make sure the conductors are correctly assigned and firmly seated in the terminals.

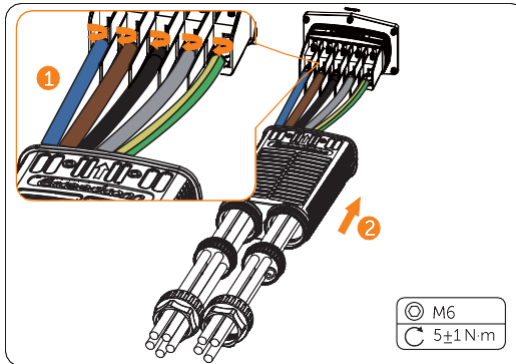

Figure 7-14 Connecting the Grid cable

**Step 4:** Secure the L1, L2, L3, N conductors of the assembled EPS cable with M6 screws (Part Q2). (Torque:  $5.0 \pm 1$  N·m) Make sure the conductors are correctly assigned and firmly seated in the terminals. Connect the enclosure of the AC connector to the inverter, insert the waterproof seals into the AC connector, and tighten the swivel nuts of the connector.

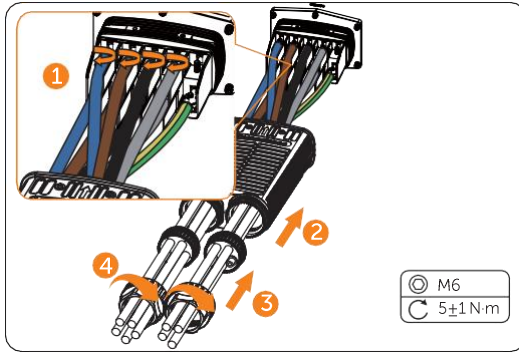

Figure 7-15 Connecting the EPS cable

**Step 5:** Connect the assembled AC connector to the AC port of the inverter, tighten the two M4\*12 screws (Part R2) on the AC connector enclosure (Torque:  $1.5 \pm 0.3$  N·m) and tighten the swivel nuts clockwise.

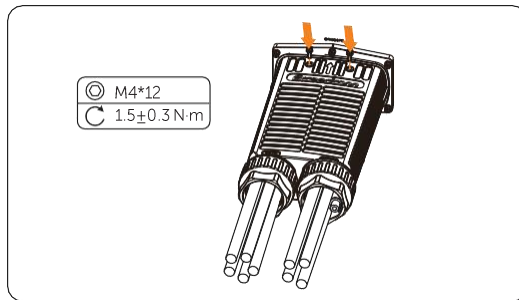

Figure 7-16 Securing the AC connector on the inverter

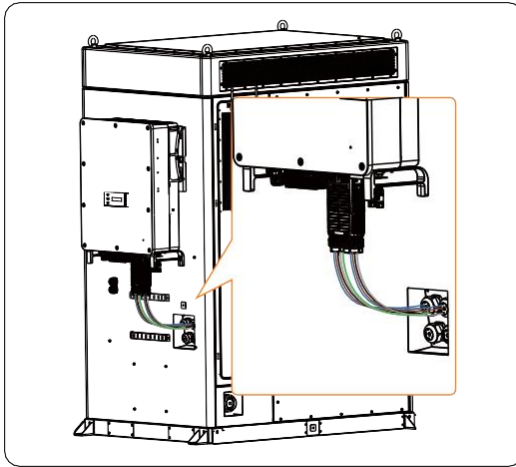

Figure 7-17 Well connected AC connector

**⚠ DANGER!**

- Before powering on the inverter, make sure the AC connector has been installed correctly on the Grid and EPS terminal even if the EPS terminal is not wired. Otherwise, electrical shock may be caused by high voltage, resulting in serious personal injury or death.

**⚠ WARNING!**

- Reinstall AC terminal caps immediately after removing the connectors from terminals.

### 7.2.4 PV Connection

 **DANGER!**

- High DC voltage will be generated by PV modules when exposed to sunlight. Death or lethal injuries will occur due to electric shock.
- Make sure the DC switch and AC breaker are disconnected from the inverter before connection.
- Make sure that the PV module output is well insulated to ground.

 **CAUTION!**

- Power is fed from more than one source and more than one live circuit.

### Requirements for PV connection

- Open circuit voltage and working voltage
  - » The open circuit voltage of the module array should be less than the maximum PV input voltage (1000 V) of the inverter. Otherwise the inverter may be damaged.
  - » The working voltage should be within the MPPT voltage range (160-950 V). Otherwise, the inverter will prompt **PV Volt Fault**. Consider the impact of low temperature on the voltage of the photovoltaic panels, as lower temperatures tend to result in higher voltages.
  - » The working voltage should be within the full load MPPT range (320-800V). Otherwise, the inverter will prompt derating protection.
- PV module
  - » The PV modules within the same MPPT channel are of the same brand. Additionally, the strings within the same channel should have identical quantities, and be aligned and tilted identically.
  - » The positive or negative pole of the PV modules is not grounded.
  - » The positive cables of the PV modules must be connected with positive DC connectors.
  - » The negative cables of the PV modules must be connected with negative DC connectors.

## Wiring procedures

**Step 1:** Strip approx. 7 mm of the cable insulation.

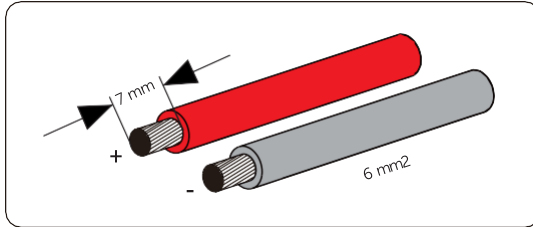

Figure 7-18 Stripping the PV cable

**Step 2:** Insert the stripped cable into the PV pin contact (Part I2 and Part J2). Ensure that the stripped cable and the PV pin contact are of the same polarity. Crimp it with a crimping tool for PV terminal.

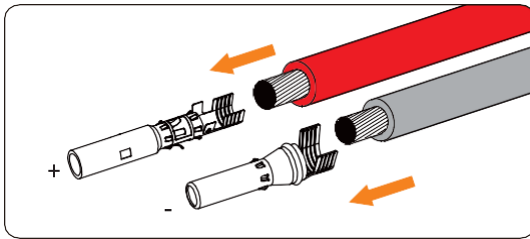

Figure 7-19 Inserting the PV pin contact

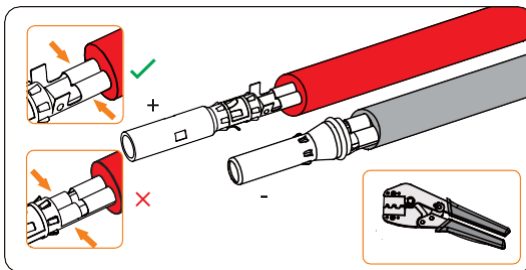

Figure 7-20 Crimping the terminal

### ⚠ WARNING!

- To mitigate the risk of fire, it is crucial to utilize a dedicated crimping tool specifically designed for PV installations to ensure secure and reliable connections.

**Step 3:** Thread the PV cable through the swivel nut and insert the cable into the PV connector until a "Click" is heard. Gently pull the cable backward to ensure a firm connection. Tighten the swivel nut clockwise. Verify that the PV connectors have the correct polarity before connection.

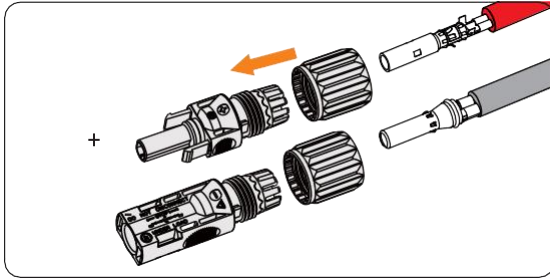

Figure 7-21 Threading the PV cable

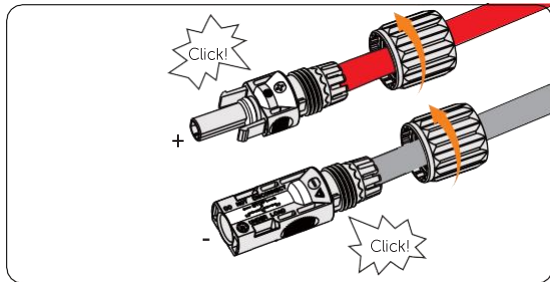

Figure 7-22 Securing the PV cable

**Step 4:** Use a multimeter to measure the positive and negative voltage of the assembled PV connectors. Make sure the open circuit voltage does not exceed the input limit of 1000 V.

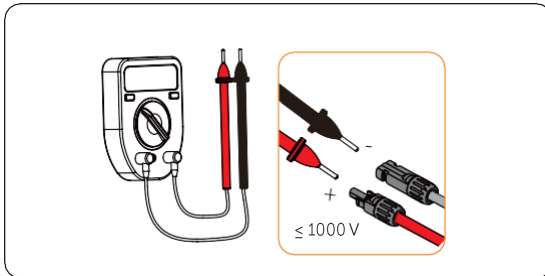

Figure 7-23 Measuring the voltage of PV connectors

**NOTICE!**

- If the voltage reading is negative, it indicates an incorrect DC input polarity. Please check if the wiring connections on the multimeter is correct or PV connectors are not mistakenly connected.

**Step 5:** Remove the PV terminal caps and connect the assembled PV connectors to corresponding terminals until there is an audible "Click". The PV+ on the string side must be connected to the PV+ on the inverter side, and the PV- on the string side must be connected to the PV- on the inverter side.

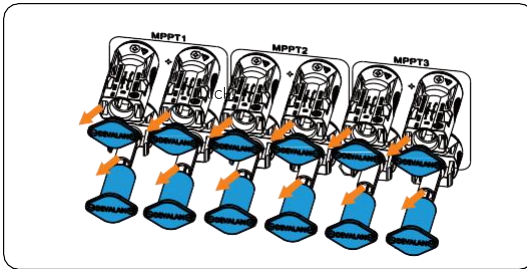

Figure 7-24 Connecting the PV cable

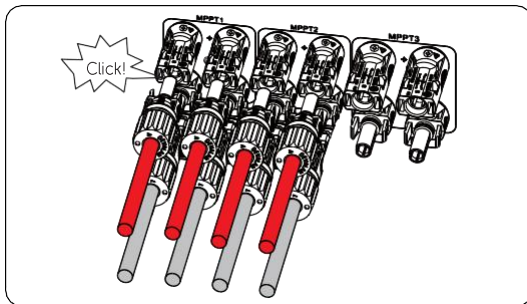

Figure 7-25 Connecting assembled PV cables to the inverter

**Step 6:** Seal the unused positive and negative PV terminals with corresponding PV dustproof buckles (Part S2 and Part T2). Reinstall them immediately after removing the connectors from terminals.

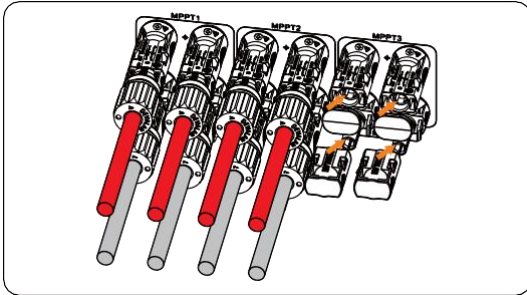

Figure 7-26 Installing PV dustproof buckles

**Step 7:** Secure the PV cables to the bracket with cable ties.

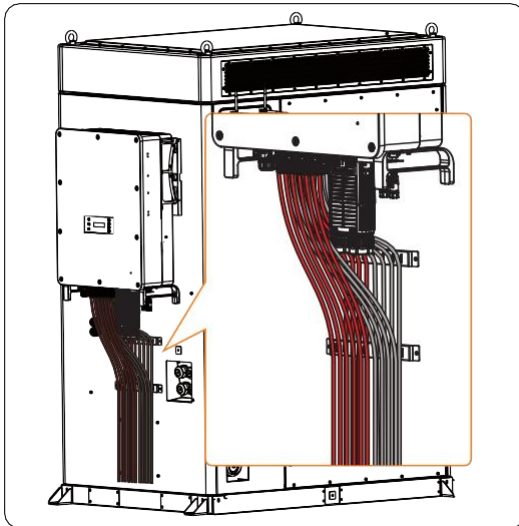

Figure 7-27 Well connected PV cables

## 7.2.5 Battery Power Cable Connection



- Make sure the breaker of battery is in OFF position.
- Always ensure correct polarity. Never reverse the polarity of the battery cables as this will result in inverter damage.

### Requirements for battery connection

- Required battery
  - » The inverter is equipped with two independent battery terminals, allowing for connection to two battery cabinets. Max charge and discharge current is 160 (80\*2) A for each BAT terminal.
  - » Make sure the input voltage of each BAT terminal is higher than minimum voltage 180 V and lower than maximum input voltage 820 V.
- Micro circuit breaker (MCB)
  - » If local regulations mandate the use of a DC MCB between the battery and the inverter, install a non-polar DC MCB.
  - » Nominal voltage of DC MCB should be larger than maximum voltage of battery.

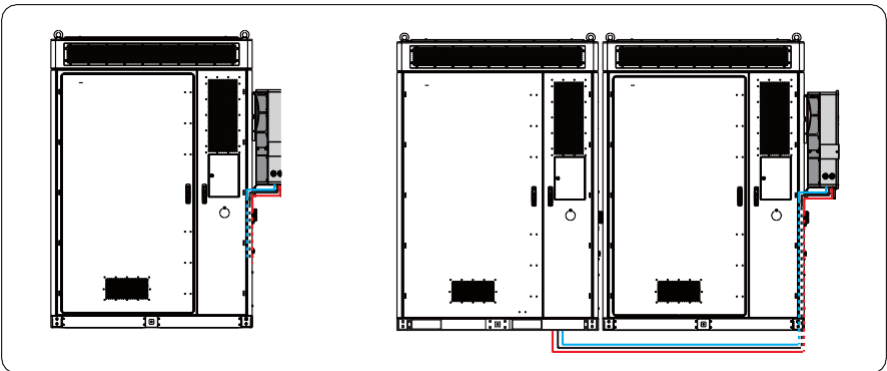

Figure 7-28 Inverter with battery cabinet(s)

Wiring procedures

NOTICE!

- The Grid and EPS cables of the inverter outlet from the Grid and EPS port in "Figure 7-7 Prefabricated inverter cables in battery cabinet", please strictly follow the steps below.
- When the battery capacity requires expansion, BAT2 can be connected to AELIO-B100 or AELIO-B200 battery cabinets with the same wiring method.

**Step 1:** Disassemble the battery connectors (Part G2 and Part H2).

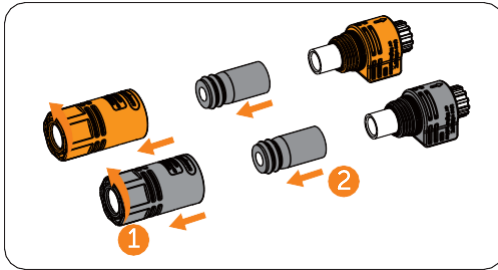

Figure 7-29 Disassembling battery connectors

**Step 2:** Pull the cable support sleeve over the battery cables and then the swivel nut to the enclosure. Tighten the swivel nut.

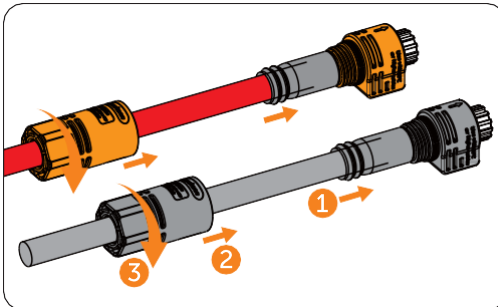

Figure 7-30 Tightening the battery connector

**Step 3:** Loosen the screws on the battery protective cover and remove the cover. Pull out the battery caps.

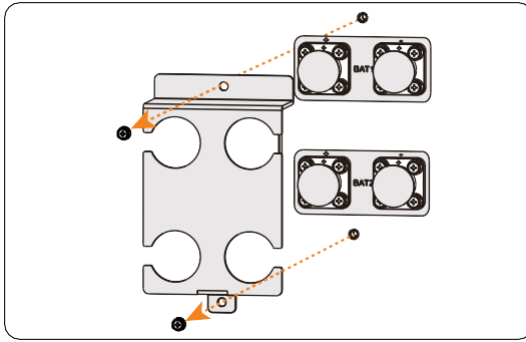

Figure 7-31 Removing the battery protective cover

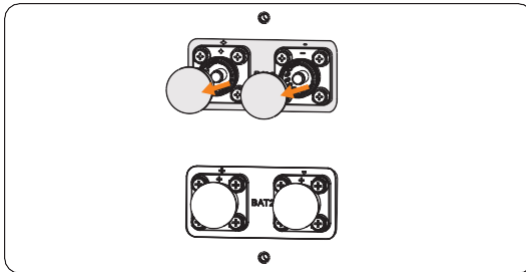

Figure 7-32 Removing battery caps

**Step 4:** Connect the assembled battery connectors to corresponding terminals until there is an audible "Click". The BAT+ on the string side must be connected to the BAT+ on the inverter side, and the BAT- on the string side must be connected to the BAT- on the inverter side. Gently pull the cable backward to ensure firm connection.

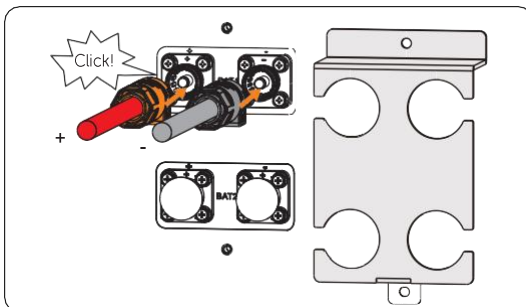

Figure 7-33 Connecting assembled battery cables

**Step 5:** After the battery cables are connected, install the battery protective cover and secure the cover on the inverter with screws.

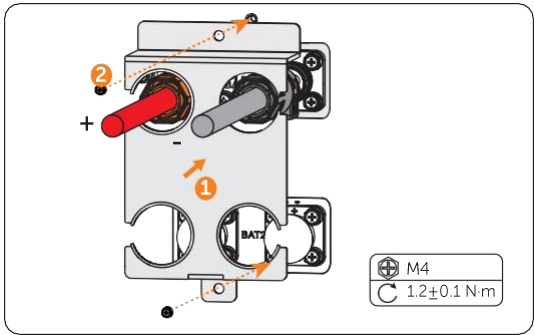

Figure 7-34 Installing the battery protective cover

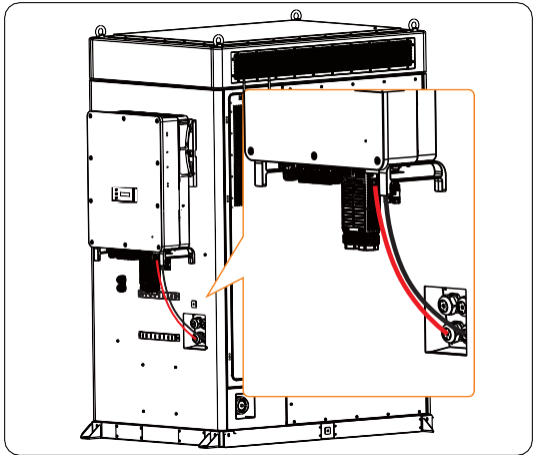

Figure 7-35 Well connected battery cables

**WARNING!**

- Seal the unused battery terminals with original terminal caps.
- Keep the terminal caps in a safe place if battery cables are connected to the inverter.
- Reinstall it immediately after removing the connectors from terminals.

**NOTICE!**

- Please refer to the battery document for specific wiring procedures on the battery side.

## 7.2.6 COM 1 Communication Connection

### Pin assignment of COM 1 terminal

The COM 1 terminal is used for cabinet and inverter communication via PARALLEL-1 communication terminal, parallel connection and via PARALLEL-1 and PARALLEL-2 communication terminal, battery communication via BMS-1 and BMS-2 terminal, external device communication via RS485 and DRM function.

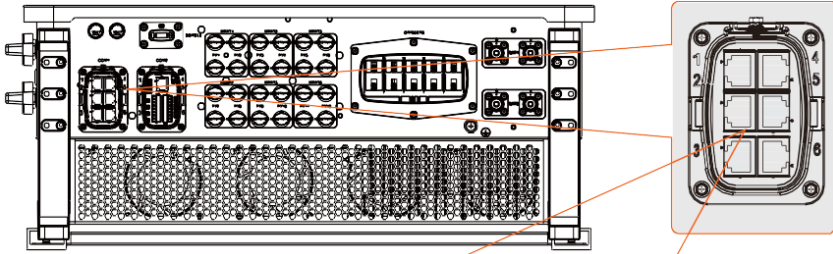

**PARALLEL 1**  
 1: PARALLEL\_485A  
 2: PARALLEL\_485B  
 3: DATA\_BUS  
 4: PARALLEL\_CANH  
 5: PARALLEL\_CANL  
 6: GND\_COM  
 7: PARALLEL\_SYNC1  
 8: PARALLEL\_SYNC2

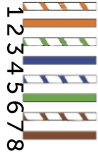

**PARALLEL 2**  
 1: PARALLEL\_485A  
 2: PARALLEL\_485B  
 3: DATA\_BUS  
 4: PARALLEL\_CANH  
 5: PARALLEL\_CANL  
 6: GND\_COM  
 7: PARALLEL\_SYNC1  
 8: PARALLEL\_SYNC2

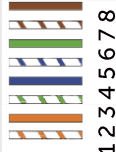

**BMS1**  
 1: BAT\_TEMP  
 2: GND\_COM  
 3: GND\_COM  
 4: BMS1\_CANH  
 5: BMS1\_CANL  
 6: BAT\_WAKEUP\_POWER  
 7: BMS1\_485A  
 8: BMS1\_485B

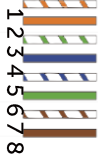

**BMS2**  
 1: BAT\_TEMP  
 2: GND\_COM  
 3: GND\_COM  
 4: BMS2\_CANH  
 5: BMS2\_CANL  
 6: BAT\_WAKEUP\_POWER  
 7: BMS2\_485A  
 8: BMS2\_485B

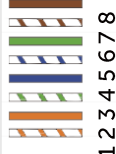

**RS485**  
 1: REMOTE\_485A  
 2: REMOTE\_485B  
 3: NC  
 4: PARALLEL\_485AA  
 5: PARALLEL\_485BB  
 6: NC  
 7: REMOTE\_485A  
 8: REMOTE\_485B

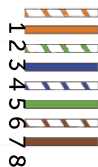

**DRM**  
 1: DRM1/5  
 2: DRM2/6  
 3: DRM3/7  
 4: DRM4/8  
 5: +3.3V\_COM  
 6: COM/DRM0  
 7: GND\_COM  
 8: GND\_COM

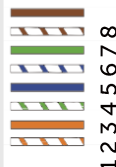

NOTICE!

The COM 1 cables of the inverter outlet from the **COM 1 port** in "Figure 7-7 Prefabricated inverter cables in battery cabinet", please strictly follow the steps below.

Cabinet and inverter communication and parallel communication connection

The inverter provides the parallel connection function. One inverter will be set as the "Master inverter" to control the other "Slave inverters" in the system.

- Parallel connection wiring procedure

**Step 1:** Loosen the screws on the COM 1 terminal. Pinch the tabs on the sides of the COM 1 connector enclosure and pull it at the same time to disassemble it.

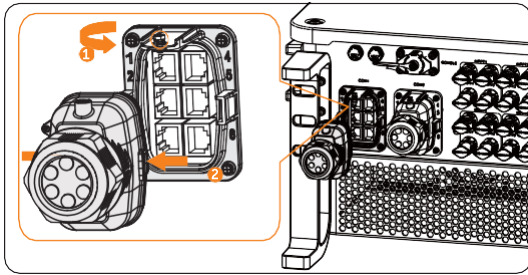

Figure 7-36 Removing the connector enclosure

**Step 2:** Anti-clockwise loosen the swivel nut and pull out the sealing plugs. Keep the sealing plugs still in the cable support sleeve if you choose not to connect the cable.

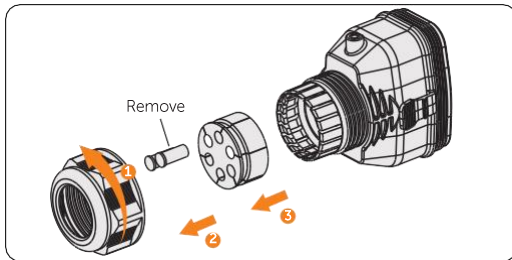

Figure 7-37 Disassembling the connector

**Step 3:** Thread the network cables.

- » Method 1: If your network cable has already been connected with RJ45 terminal (Part E2), you can directly thread the cable through the swivel nut, cable support sleeve and connector enclosure in sequence.

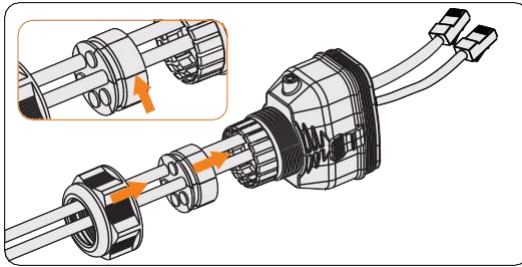

Figure 7-38 Threading the cables with RJ45 terminal

- » Method 2: If your network cable is not connected to an RJ45 terminal, you will need to assemble the cable before proceeding.

Thread the cables without RJ45 terminal through the swivel nut, cable support sleeve, and connector enclosure in sequence. Strip approx. 15 mm of the cable insulation.

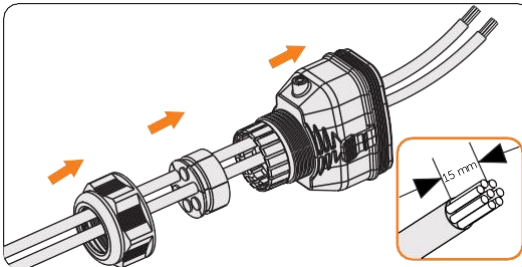

Figure 7-39 Threading the cables and stripping the insulation

Insert the stripped section into the RJ45 terminal. Crimp it tightly with a crimping tool for RJ45. Pay attention to pin order of RJ45 terminal.

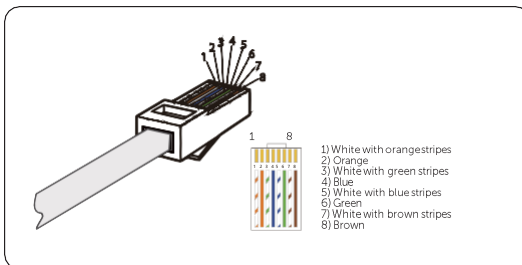

Figure 7-40 Crimping the communication cable

NOTICE!

- Use network cable tester to test the crimped cable before connecting to the inverter.

**Step 4:** Install the network cables with a crimped RJ45 terminal to Parallel-1 and Parallel -2 of cable clamp (Part C2) according to the labeling.

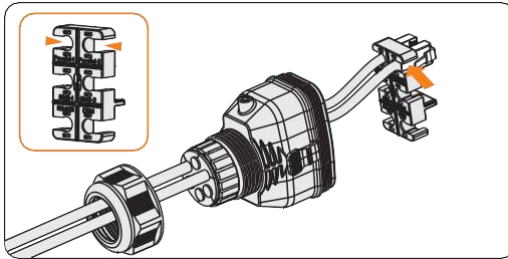

Figure 7-41 Installing the cable to the cable clamp

**Step 5:** Connect the assembled connector to COM 1 terminal. Ensure the cable clamp tongue is well inserted into the slot of terminal. You will hear an audible "Click" if it is connected securely. Lightly pull the cable for double check its connection.

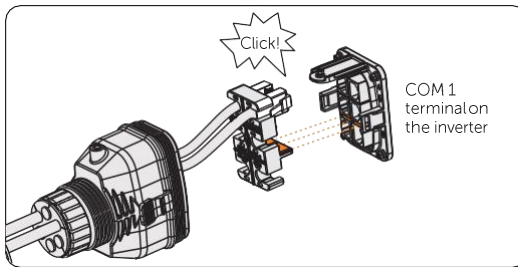

Figure 7-42 Inserting the connector to COM 1

- Step 6:** Secure the assembled connector on COM 1 terminal.
- Install the connector enclosure back into the COM 1 terminal.
  - Install the cable support sleeve into the enclosure.
  - Tighten M3 screw to secure it. (Torque:  $1.2 \pm 0.1$  N·m)
  - Clockwise tighten the swivel nut to finish the COM 1 wiring connection.

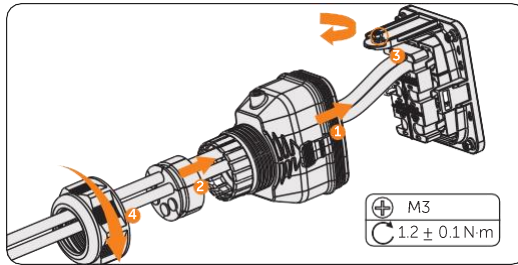

Figure 7-43 Securing the connector

### BMS communication connection

Through BMS-1 and BMS-2 communication terminal, the inverter can be connected to two AELIO-B100 battery cabinet.

- BMS connection diagram

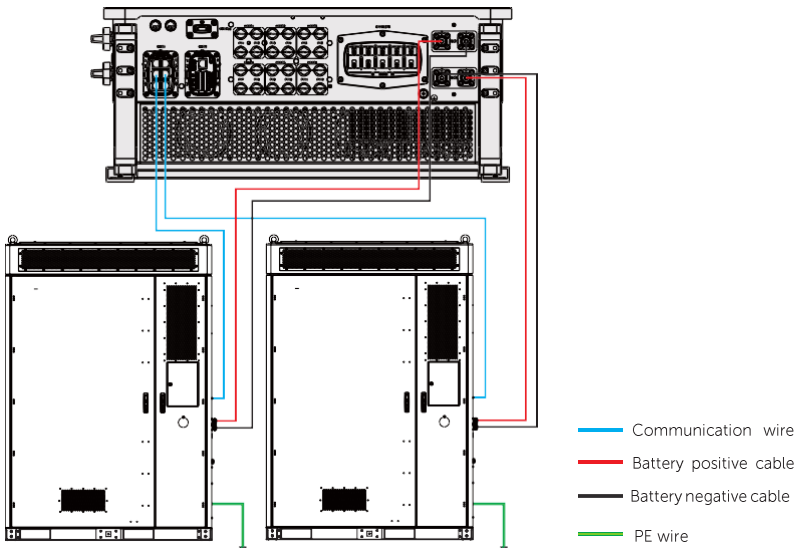

Figure 7-44 BMS connection diagram

- BMS wiring procedure

- Step 1:** Loosen the screws on the COM 1 terminal. Pinch the tabs on the sides of the COM1 connector enclosure and pull it at the same time to remove it.
- Step 2:** Anti-clockwise loosen the swivel nut and pull out the sealing plugs. Keep them still in the cable support sleeve if you choose not to connect the cable.
- Step 3:** Thread the cables through the swivel nut, cable support sleeve, and connector enclosure in sequence.
- Step 4:** Install the network cables to BMS-1 and BMS -2 of cable clamp according to the labeling.

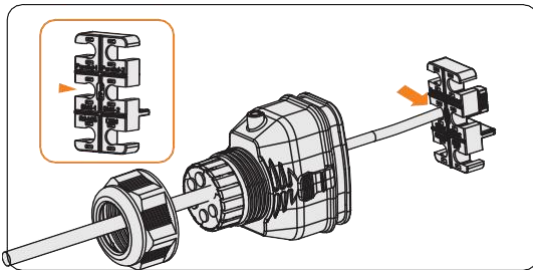

Figure 7-45 Installing RJ45 terminal to the cable clamp

- Step 5:** Connect the assembled connector to COM 1 terminal. Make sure the cable clamp tongue is well inserted into the slot of terminal. You will hear an audible "Click" if it is connected securely. Lightly pull the cable backward for double check its connection.
- Step 6:** Secure the assembled connector on COM 1 terminal.
- a. Install the connector enclosure back into the COM 1 terminal.
  - b. Install the cable support sleeve into the enclosure.
  - c. Tighten M3 screw to secure it. (Torque:  $1.2 \pm 0.1$  N·m)
  - d. Clockwise tighten the swivel nut to finish the COM 1 wiring connection.

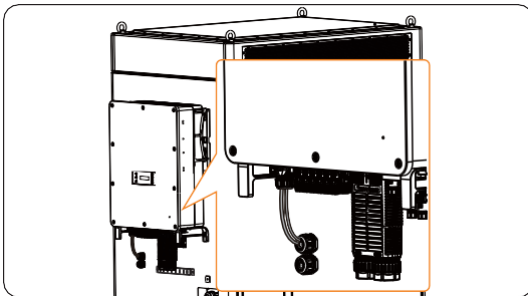

Figure 7-46 Well connected COM 1 cables

### RS485 communication connection

For SolaX products, such as the Adapter Box, EV-Charger and etc., they can be connected to pin4 and pin5. As for pin1, pin2, pin7, and pin8 they can be utilized to connect devices other than SolaX products. If you require simultaneous connections of multiple devices, a splitter adapter can be employed.

#### NOTICE!

- Please refer to corresponding user manual for the specific application of Adapter Box, EV-Charger and Datahub.
- Not all devices are compatible with 8 pin Network cables. In cases where 8 pin Network cables are not supported, it is required to re-crimp the RJ45 terminal according to the pin assignment.

- External device wiring procedure

**Step 1:** Loosen the screws on the COM 1 terminal. Pinch the tabs on the sides of the COM 1 connector enclosure and pull it at the same time to remove it.

**Step 2:** Anti-clockwise loosen the swivel nut and pull out the sealing plugs. Keep the sealing plugs still in the cable support sleeve if you choose not to connect the cable.

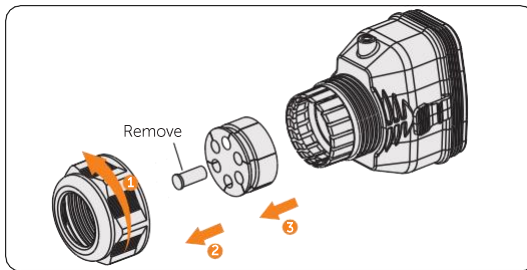

Figure 7-47 Disassembling the connector

**Step 3:** Thread the cables without RJ45 terminal through the swivel nut, cable support sleeve, and connector enclosure in sequence. Strip approx. 15 mm of the cable insulation.

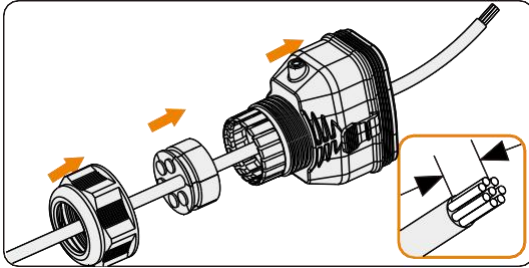

Figure 7-48 Threading the cables and stripping the insulation

**Step 4:** Insert the stripped section into the RJ45 terminal. Crimp it tightly with a crimping tool for RJ45. Pay attention to pin order of RJ45 terminal.

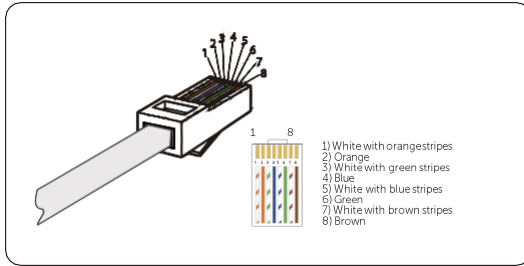

Figure 7-49 Crimping the communication cable

**NOTICE!**

- Use network cable tester to test the crimped cable before connecting to the inverter.

**Step 5:** Install the network cable of the crimped RJ45 terminal to RS485 of cable fixture according to the labeling.

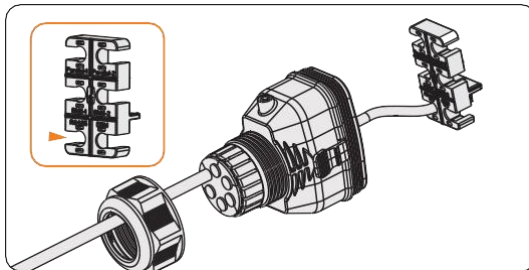

Figure 7-50 Installing RJ45 terminal to the cable fixture

**Step 6:** Connect the assembled connector to COM 1 terminal. Make sure the cable fixture tongue is well inserted into the slot of terminal. You will hear an audible "Click" if it is connected securely. Lightly pull the cable backward for double check its connection.

**Step 7:** Secure the assembled connector on COM 1 terminal.

- Install the connector enclosure back into the COM 1 terminal.
- Install the cable support sleeve into the enclosure.
- Tighten M3 screw to secure it. (Torque:  $1.2 \pm 0.1$  N·m)
- Clockwise tighten the swivel nut to finish the COM 1 wiring connection.

### DRM connection (applicable to AS/NZS 4777)

According to AS/NZS 4777, the inverter needs to support the function of demand response mode (DRM). With the use of an external control box, active or reactive power regulation can be realized in a timely and fast manner, and the inverter can be operated stably during the process of regulation.

DRM 0, DRM 1 and DRM 5 are available now.

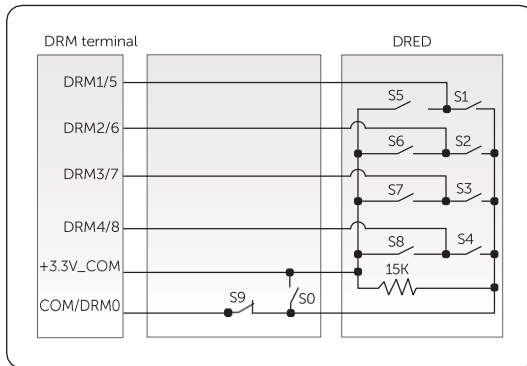

Figure 7-51 DRED connection diagram

Table 7-3 Descriptions of DRM

Mode	Pin	Requirement
DRM 0	Pin 6	<ul style="list-style-type: none"> <li>When S0 is turned on, the inverters shut down.</li> <li>When S0 is turned off, the inverters restore grid connection.</li> </ul>
DRM 1	Pin 1	<ul style="list-style-type: none"> <li>When S1 is turned on, the inverters do not input active power.</li> </ul>
DRM 5	Pin 1	<ul style="list-style-type: none"> <li>When S5 is turned on, the inverters do not output active power.</li> </ul>

- DRM connection wiring procedure

- Step 1:** Loosen the screws on the COM 1 terminal. Pinch the tabs on the sides of the COM 1 connector enclosure and pull it at the same time to remove it.
- Step 2:** Anti-clockwise loosen the swivel nut and pull out the sealing plugs. Keep them still in the cable support sleeve if you choose not to connect the cable.
- Step 3:** Thread the cable through the swivel nut, cable support sleeve, and connector enclosure in sequence.
- Step 4:** Install the network cable of the crimped RJ45 terminal to RS485 of cable fixture according to the labeling.

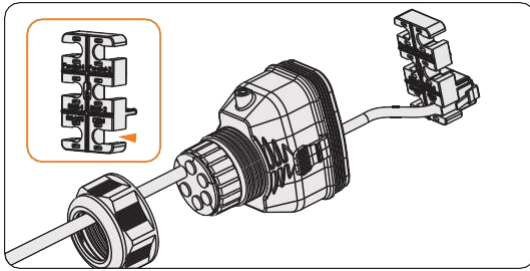

Figure 7-52 Installing RJ45 terminal to the cable fixture

- Step 5:** Connect the assembled connector to COM 1 terminal. Make sure the cable fixture tongue is well inserted into the slot of terminal. You will hear an audible "Click" if it is connected securely. Lightly pull the cable backward for double check its connection.
- Step 6:** Secure the assembled connector on COM 1 terminal.
- a. Install the connector enclosure back into the COM 1 terminal.
  - b. Install the cable support sleeve into the enclosure.
  - c. Tighten M3 screw to secure it. (Torque:  $1.2 \pm 0.1$  N·m)
  - d. Clockwise tighten the swivel nut to finish the COM 1 wiring connection.

## 7.2.7 COM 2 Communication Connection

### Pin assignment of COM 2 terminal

The COM 2 terminal is used for Meter/CT connection, ripple control and DIO function.

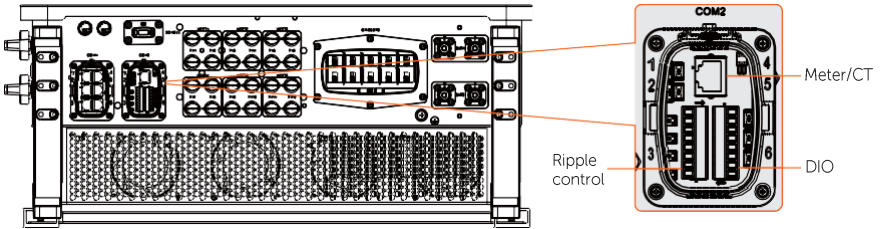

Table 7-4 Pin assignment of COM 2 terminal

Pin	Pin assignment
Meter/CT	
1	CT_R1_CON
2	CT_S1_CON
3	CT_T1_CON
4	METER_485A
5	METER_485B
6	CT_T2_CON
7	CT_S2_CON
8	CT_R2_CON
Ripple control	
1	RP_K4
2	GND_COM
3	RP_K3
4	GND_COM
5	RP_K2
6	GND_COM
7	RP_K1
8	GND_COM

Pin	Pin assignment
DIO port	
1	DO_1
2	DO_2
3	DI_1+
4	DI_1-
5	DI_2+
6	DI_2-
7	GND_COM
8	EPSBOX_RELAY_VCC

### CT/Meter connection

The inverter should work with an electric meter or current transformer (CT for short) to monitor household electricity usage. The electricity meter or CT can transmit the relevant electricity data to the inverter or platform.

This section only introduces the wiring of the CT/Meter port of the inverter. For wiring procedures of the CT and meter side, see ["14.4 CT/Meter Connection Scenarios"](#).



- Compatible meters and CTs must be properly connected to the inverter, otherwise, the inverter will shut down and prompt a **Meter Fault** alarm.
- Meters and CTs that will be connected to the inverter must be authorized by SolaX. Unauthorized meters and CTs might be incompatible and cause damages to the inverter. SolaX will not be responsible for the impact caused by the use of other appliances.

Table 7-5 CT/Meter pin definition

	Pin	Pin assignment
For CT connection	1	CT_R1_CON
	2	CT_S1_CON
	3	CT_T1_CON
For Meter connection	4	METER_485A
	5	METER_485B

For CT connection	6	CT_T2_CON
	7	CT_S2_CON
	8	CT_R2_CON

- CT/Meter wiring procedure

**Step 1:** Loosen the screws on the COM 2 terminal. Pinch the tabs on the sides of the COM 2 connector enclosure and pull it at the same time to remove it.

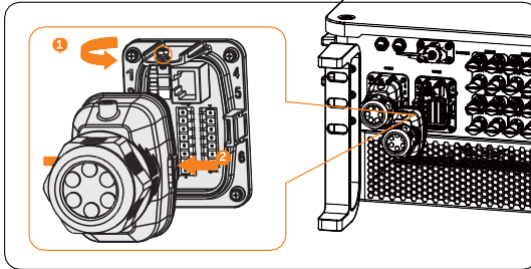

Figure 7-53 Disassembling the COM 2 terminal

**Step 2:** Loosen the swivel nut and pull out the sealing plugs. Keep them still in the cable support sleeve if you choose not to connect the cable.

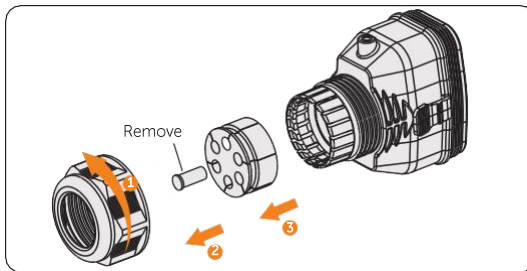

Figure 7-54 Disassembling the connector

**Step 3:** Directly thread the cable through the swivel nut, cable support sleeve and connector enclosure in sequence.

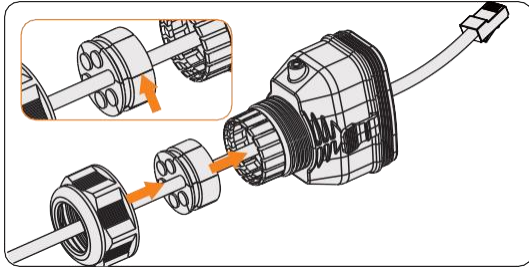

Figure 7-55 Threading the cable with RJ45 terminal

**NOTICE!**

- Use network cable tester to test the crimped cable before connection.

**Step 4:** Connect the assembled communication cable into the COM 2 terminal. Secure the assembled connector on COM 2 terminal.

- » Install the connector enclosure back into the COM 2 terminal.
- » Install the cable support sleeve into the enclosure.
- » Tighten M3 screw to secure it. (Torque:  $1.2 \pm 0.1$  N·m)
- » Clockwise tighten the swivel nut to finish the COM 2 wiring connection.

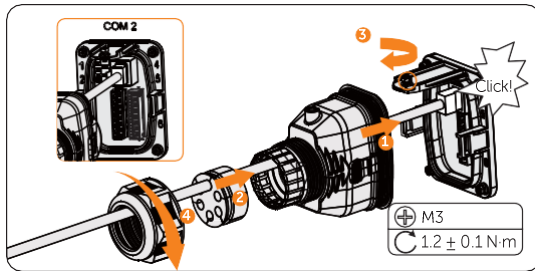

Figure 7-56 Connecting to COM 2

## Ripple control communication connection

Ripple Control is a common form of grid management. Its communication is based on superimposing a very high frequency signal onto the 50 / 60 Hz mains power. The inverter supports to connect a digital signal source (e.g. ripple control receiver) to the digital input.

- Requirements for Ripple control
  - » The signal source must be technically suitable for connection to the digital inputs. (see technical data)
  - » The connected digital signal source has a safe separation to the grid potential.
- Connection diagram for ripple control

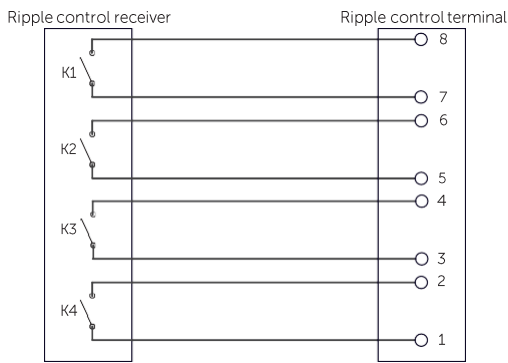

Figure 7-57 Connection diagram for ripple control

- Ripple control wiring procedure
- Step 1:** Loosen the screws on the COM 2 terminal. Pinch the tabs on the sides of the COM 2 connector enclosure and pull it at the same time to remove it.

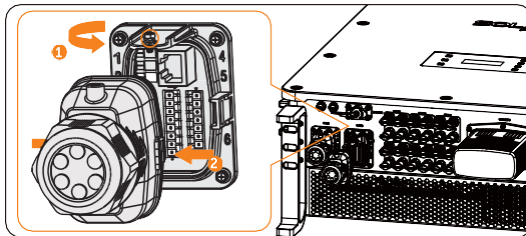

Figure 7-58 Disassembling the COM 2 terminal

**Step 2:** Loosen the swivel nut and pull out the sealing plugs. Keep them still in the cable support sleeve if you choose not to connect the cable.

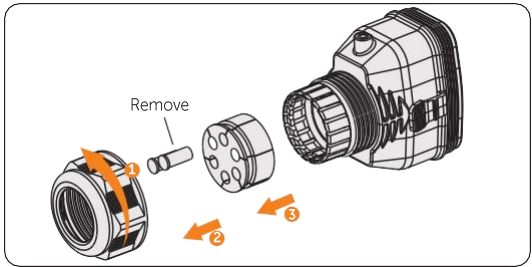

Figure 7-59 Disassembling the connector

**Step 3:** Prepare two four-core signal cables. Thread the cables through the swivel nut, cable support sleeve, and connector enclosure in sequence.

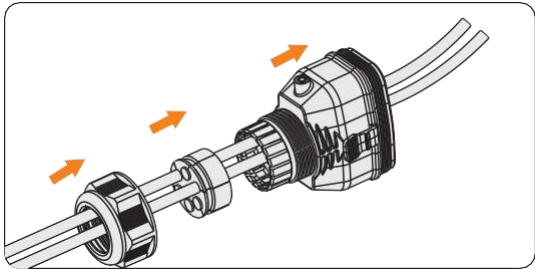

Figure 7-60 Threading the cables

**Step 4:** Strip approx. 6 mm of the cable insulation. Insert the conductors into the 8-pin terminal block (Part F2) and tighten the terminal block screws. (torque:  $0.4 \pm 0.1$  N·m) Ensure that the conductors are firmly seated in the terminal.

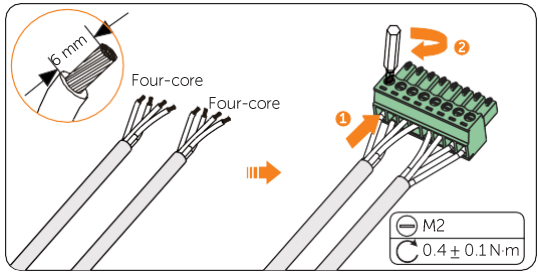

Figure 7-61 Connecting to 8-pin terminal block

**Step 5:** Connect the assembled communication cable into the COM 2 terminal. Lightly pull the cable backward to confirm tight insertion and then install the connector back.

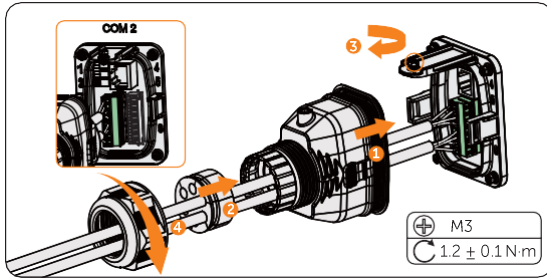

Figure 7-62 Connecting to the inverter

### DIO communication connection

DIO terminal is designed to support generator and system switch connection through dry contact.

To enhance safety and reduce the risk of injury, you can install the system switch in a readily accessible location through dry contact connection. In the event of an emergency, the system switch can be easily reached and pressed to promptly switch off the entire system, ensuring a swift response and preventing further harm.

For generator, please refer to corresponding user manual for specific application.

Table 7-6 DIO pin definition

	Pin	Pin assignment
For generator dry contact output	1	DO_1
	2	DO_2
For system switch dry contact input	3	DI_1+
	4	DI_1-
Reserved	5	DI_2+
	6	DI_2-
Reserved	7	GND_COM
For power supply	8	EPSBOX_RELAY_VCC

**NOTICE!**

- If there is strong interference in the surroundings, it is recommended to use shielding cables and ground the shielding layer of the cables through Pin 7.

- System switch connection diagram

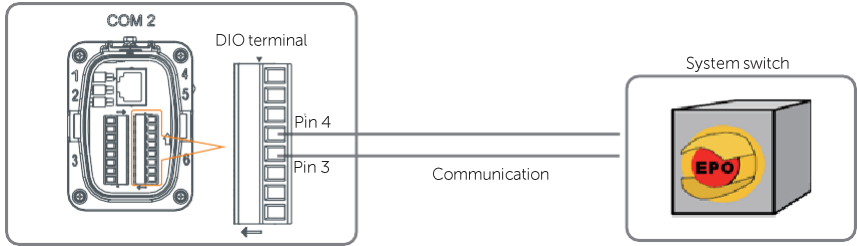

Figure 7-63 System switch connection diagram

Choose a self-locking switch for the system. When system switch is pressed, **OFF MODE (DIO SW)** will be displayed on the LCD screen and the system will be powered off. To release the switch, press it again.

- DIO wiring procedure

- Step 1:** Loosen the screws on the COM 2 terminal. Pinch the tabs on the sides of the COM 2 connector enclosure and pull it at the same time to remove it.
- Step 2:** Loosen the swivel nut and pull out the sealing plugs. Keep them still in the cable support sleeve if you choose not to connect the cable.
- Step 3:** Prepare two four-core signal cable. Thread the cables through the swivel nut, cable support sleeve, and connector enclosure in sequence.
- Step 4:** Strip approx. 6 mm of the cable insulation. Insert the conductors into the 8-pin terminal block and tighten the terminal block screws. (torque:  $0.4 \pm 0.1$  N·m) Ensure that the conductors are firmly seated in the terminal.

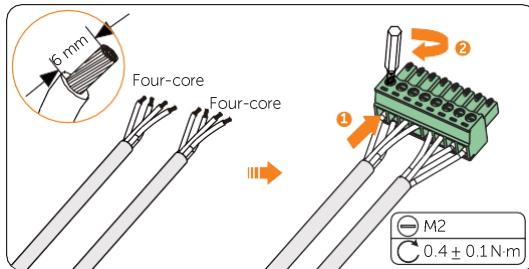

Figure 7-64 Connecting to 8-pin terminal block

**Step 5:** Connect the assembled communication cable into the COM 2 terminal. Lightly pull the cable backward to confirm tight insertion and then install the connector back.

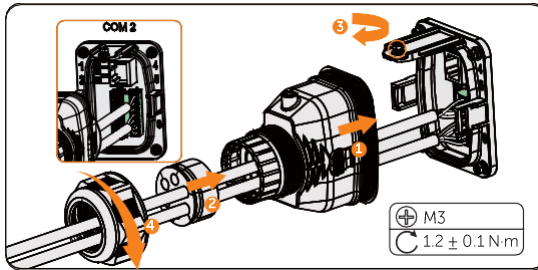

Figure 7-65 Connecting to the inverter

### 7.3 EPS Connection

Regarding the grid connection, see **Part b** in “Figure 7-1 Part that needs wiring”, please strictly follow the steps below.

#### NOTICE!

- Take out the underground electrical wiring which is buried beneath the ground.
- Regarding the terminal requirements, please refer to “14.1 Requirements for OT/DT/TO Terminal”.

**Step 1:** Use keys to open the front doors.

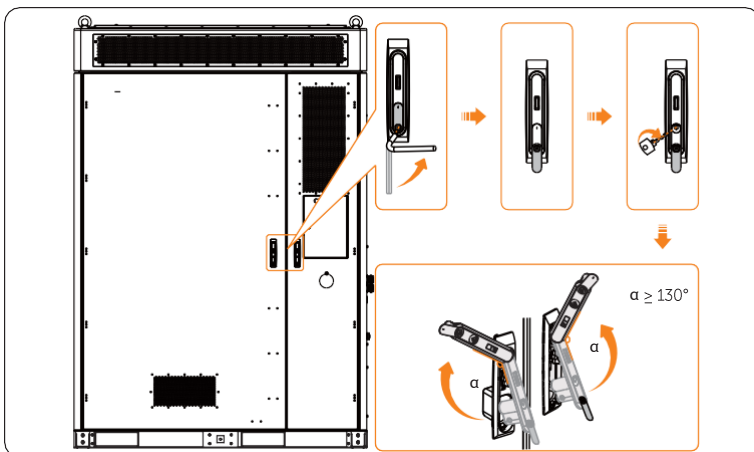

Figure 7-66 Opening front doors

**NOTICE!**

- Please keep the keys properly.

**Step 2:** Unscrew screws to open the cable hole cover.

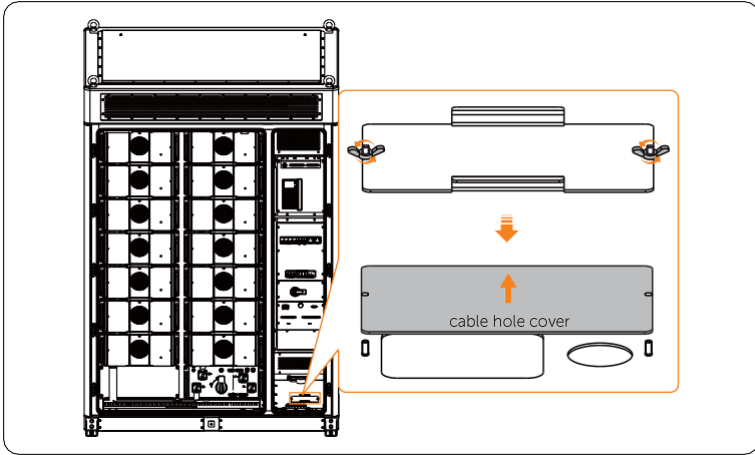

Figure 7-67 Opening cable hole cover

**Step 3:** Strip the four-core cable about 250 mm to 270 mm. Strip the cable jacket (for L1/L2/L3/N) about 20 mm.

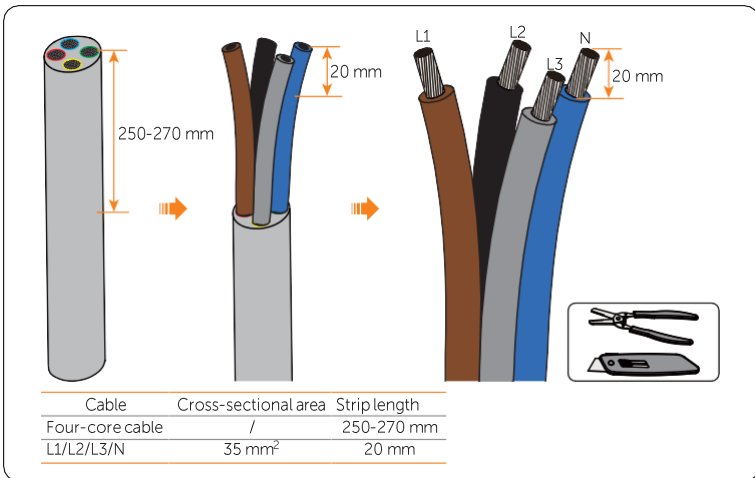

Figure 7-68 Stripping cable jacket

## NOTICE!

- It's important to give the power cable a health check before stripping it.
- It's necessary to use controlled motion to strip the insulation down the wire, to prevent damage to the wires.
- Make sure that the insulation layer has been stripped to a sufficient length so that the center conductor is fully exposed without any damage or nicks. In addition, make sure that no extra insulation remains beyond the connector once it's crimped on.

**Step 4:** Cut the heat-shrink tubing (Ø15-20 mm) to about 50 mm to 60 mm length for L1/L2/L3/N wires; Carefully slide it onto the end of the cable, and then carefully slip the wires all the way into the copper terminals (Part M1).

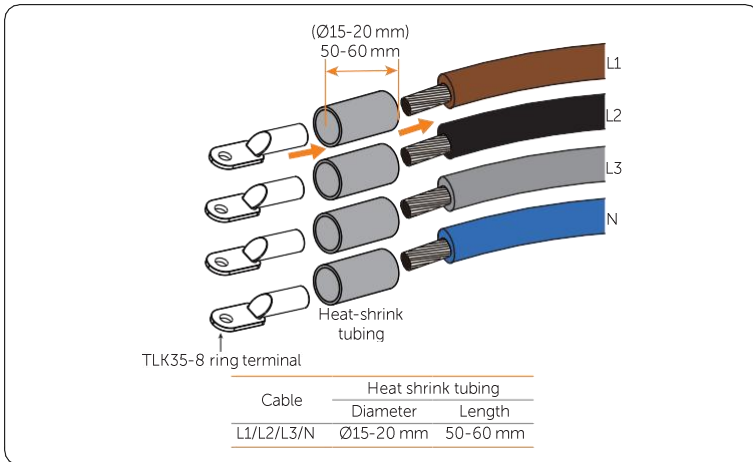

Figure 7-69 Slipping wires

**Step 5:** Crimp the terminal using hydraulic wire crimper. Since the procedure for installing a terminal is same, take the L1 wire, for instance.

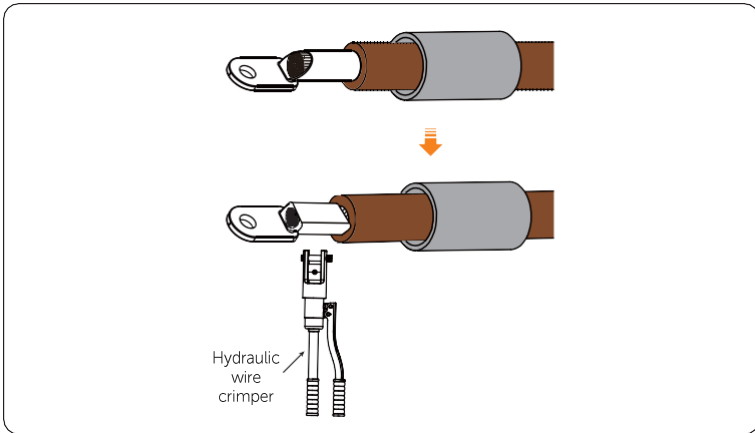

Figure 7-70 Crimping

**NOTICE!**

- Do not damage the conductor insulation while crimping.
- Do not place the conductor insulation into the terminal.

**Step 6:** Heat the heat-shrink tubing after it wraps the end of terminal.

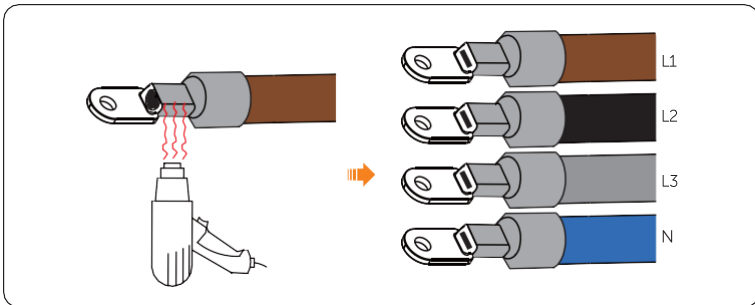

Figure 7-71 Heating

**NOTICE!**

- Move the heat gun back and forth slowly to distribute the heat evenly across the surface of heat shrink tubing.

**Step 7:** There are two options (a and b) for pulling through the EPS wires. Therefore, thread it through option a or b from the outside to the inside.

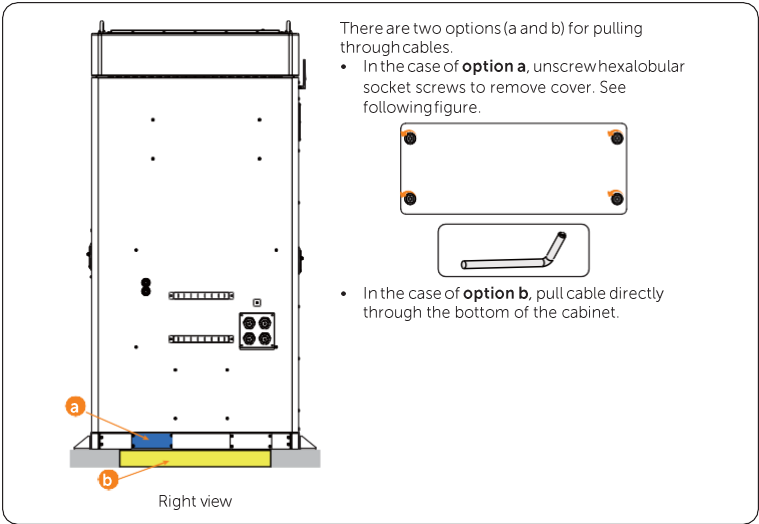

Figure 7-72 Threading EPS wires

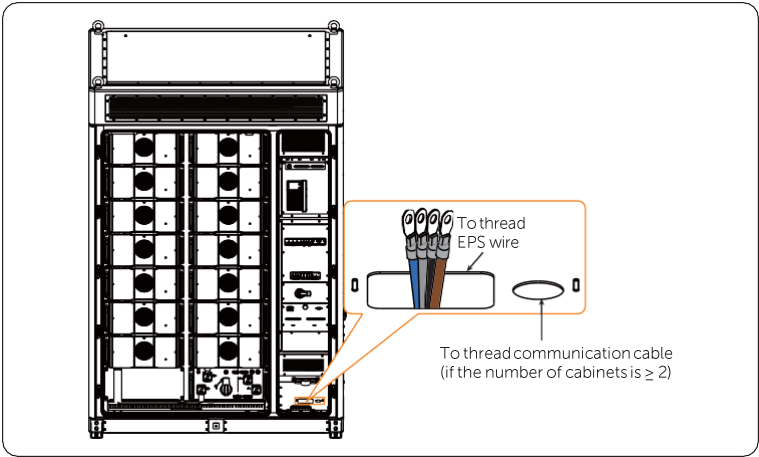

Figure 7-73 Threading EPS wires

**Step 8:** Unscrew M5 screws to open clamp.

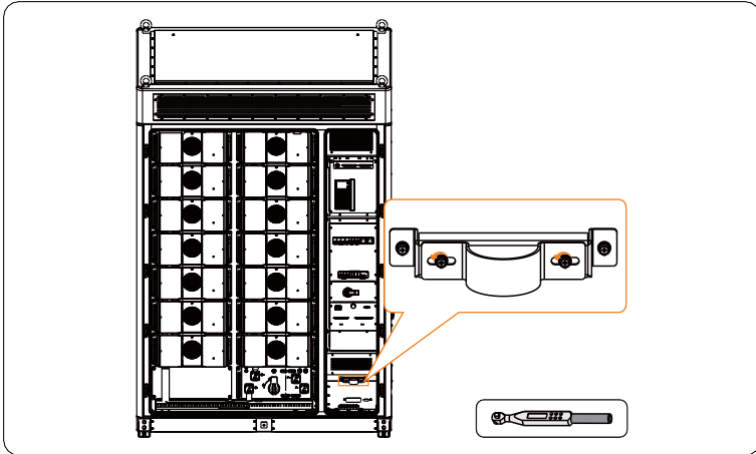

Figure 7-74 Opening clamp

**Step 9:** Run the EPS wires through the clamp, and then insert and tighten M5 screws (torque:  $2.0 \pm 0.2$  N·m).

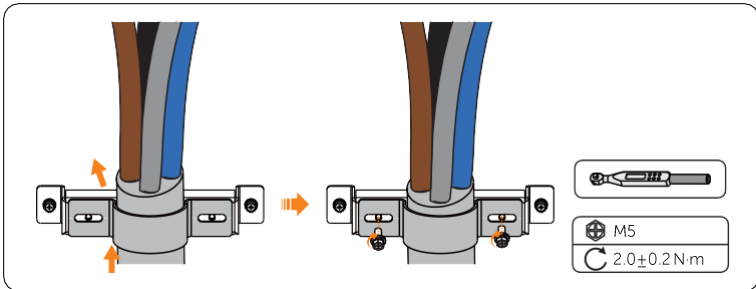

Figure 7-75 Threading EPS wires

**Step 10:** Unscrew M4 screws to remove the cover.

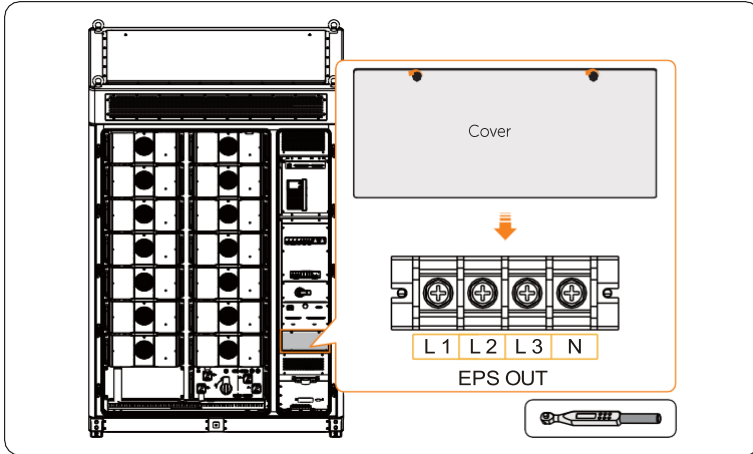

Figure 7-76 Removing cover

### NOTICE!

- Please keep the M4 screws and cover properly.

**Step 11:** Unscrew the M8 screws using torque wrench, connect the assembled L1/L2/L3/N wires to the wire interface, and then tighten them (torque:  $12\pm 1$  N·m). There are a total of 4 pieces of M8 screws.

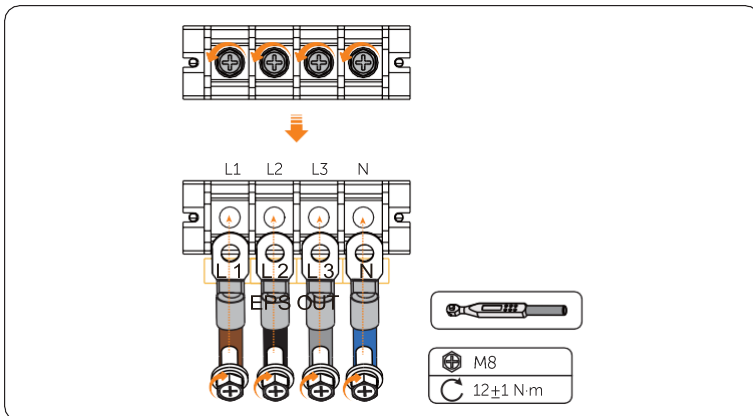

Figure 7-77 Connecting L1/L2/L3/N wires

**Step 12:** Attach the cover, and insert and tighten the M4 screws (torque:  $1.2 \pm 0.1$  N·m).

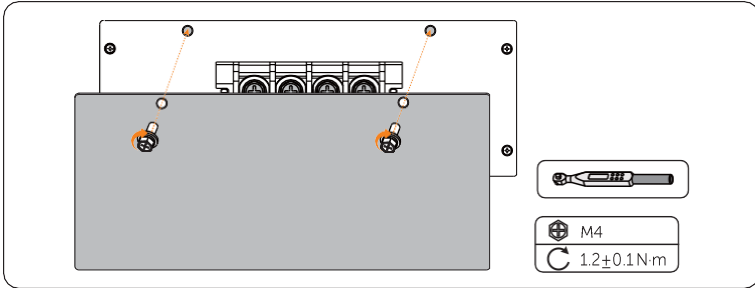

Figure 7-78 Securing cover

## 7.4 Grid Connection

Regarding the grid connection, see **Part c** in “Figure 7-1 Part that needs wiring”, please strictly follow the steps below.

### NOTICE!

- Take out the underground electrical wiring which is buried beneath the ground.
- Regarding the terminal requirements, please refer to “14.1 Requirements for OT/DT/TO Terminal”.

**Step 1:** Use keys to open the rear door.

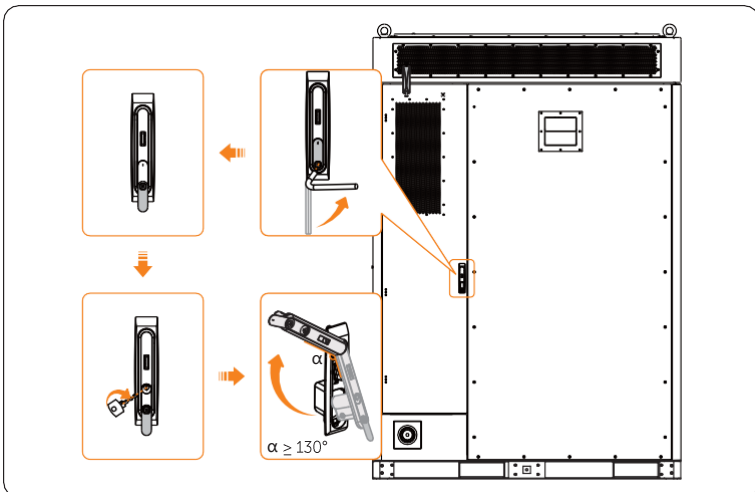

Figure 7-79 Opening rear door

**Step 2:** Unscrew screws to open the cable hole cover.

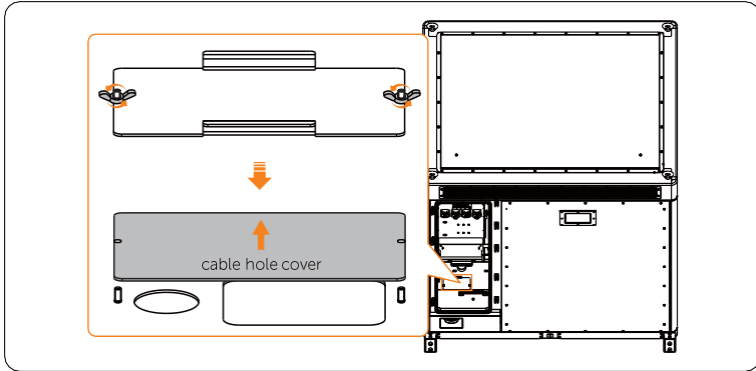

Figure 7-80 Opening cable hole cover

**Step 3:** Strip the five-core cable about 160 mm to 180 mm;  
Strip the cable jacket (for L1/L2/L3/N) about 20 mm;  
Strip the PE cable jacket about 15 mm to 20 mm.

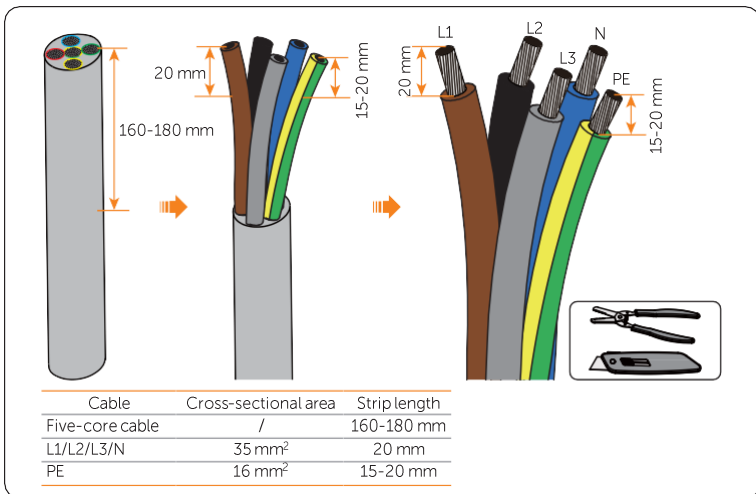

Figure 7-81 Stripping cable jacket

**NOTICE!**

- It's important to give the power cable a health check before stripping it.
- It's necessary to use controlled motion to strip the insulation down the wire, to prevent damage to the wires.
- Make sure that the insulation layer has been stripped to a sufficient length so that the center conductor is fully exposed without any damage or nicks. In addition, make sure that no extra insulation remains beyond the connector once it's crimped on.

**Step 4:** Cut the heat-shrink tubing (Ø17~25 mm) to about 50 to 60 mm length for L1/L2/L3/N wires;  
 Cut the heat-shrink tubing (Ø10-15 mm) to about 30 to 40 mm length for PE wire;  
 Carefully slide it onto the end of the cable, and then carefully slip the wires all the way into the copper terminals (Part M1).

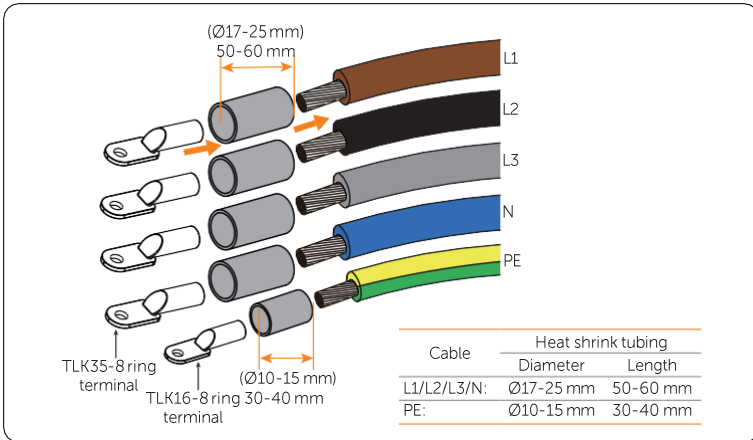

Figure 7-82 Cutting heat-shrink tubing

**Step 5:** Crimp the terminal using hydraulic wire crimper. Since the procedure for installing a terminal is same, take the L1 wire, for instance.

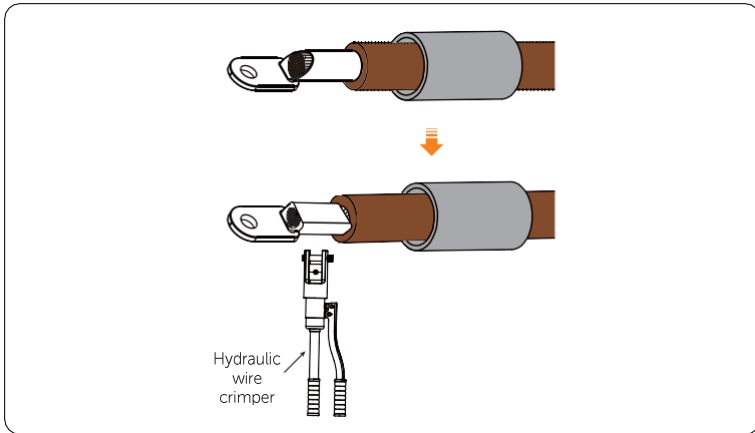

Figure 7-83 Crimping

**NOTICE!**

- Do not damage the conductor insulation while crimping.
- Do not place the conductor insulation into the terminal.

**Step 6:** Heat the heat-shrink tubing after it wraps the end of terminal.

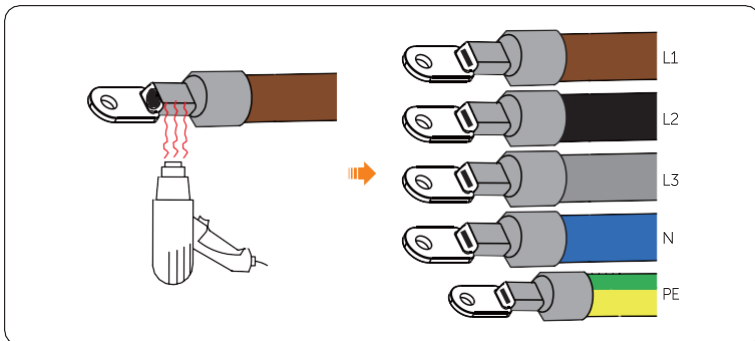

Figure 7-84 Heating heat-shrink tubing

**NOTICE!**

- Move the heat gun back and forth slowly to distribute the heat evenly across the surface of heat shrink tubing.

**Step 7:** There are two options (a and b) for pulling through the grid wires. Therefore, thread it through option a or b from the outside to the inside.

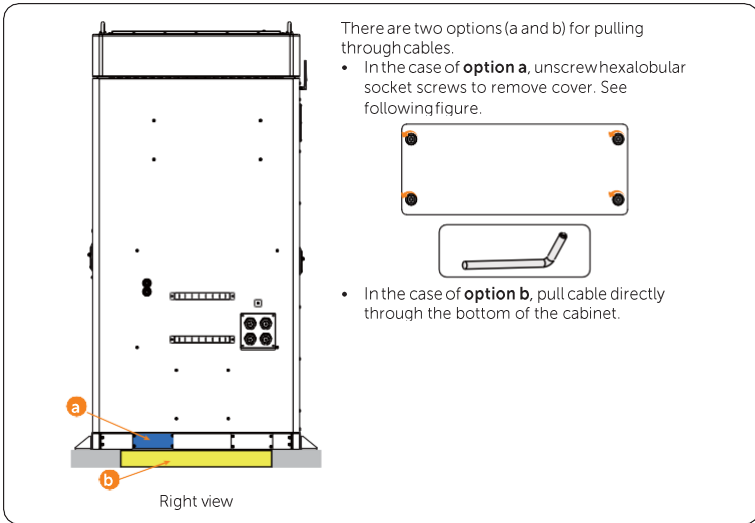

Figure 7-85 Threading grid wires

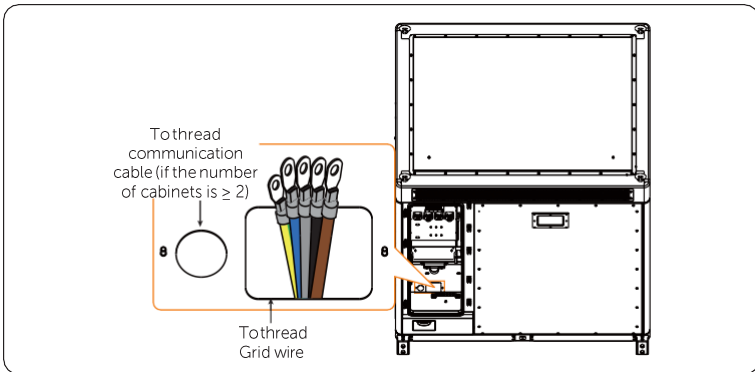

Figure 7-86 Threading grid wires

**Step 8:** Unscrew M5 screws to open clamp.

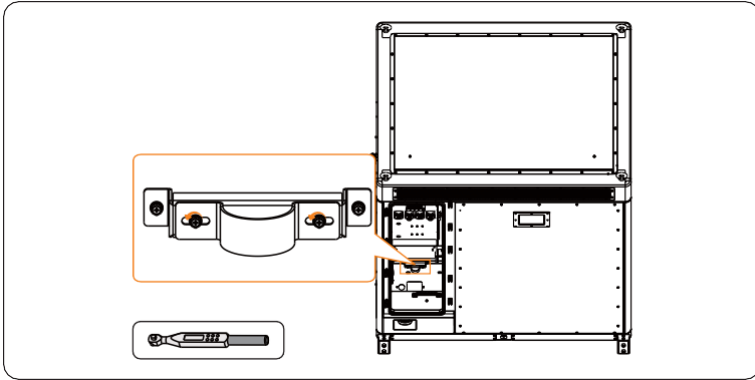

Figure 7-87 Opening clamp

**Step 9:** Run the grid wires through the clamp, and then insert and tighten M5 screws (torque:  $2.0 \pm 0.2$  N·m).

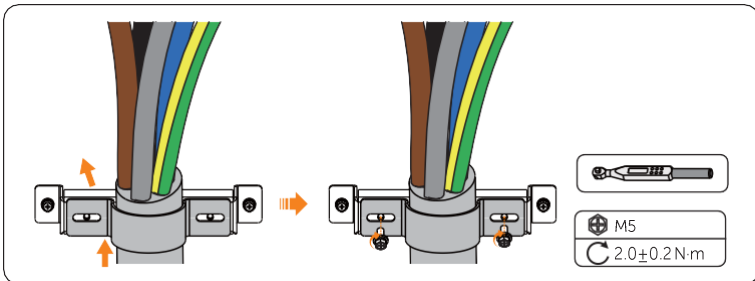

Figure 7-88 Threading grid wires

**Step 10:** Unscrew M5 screws and remove the cover from the hooks.

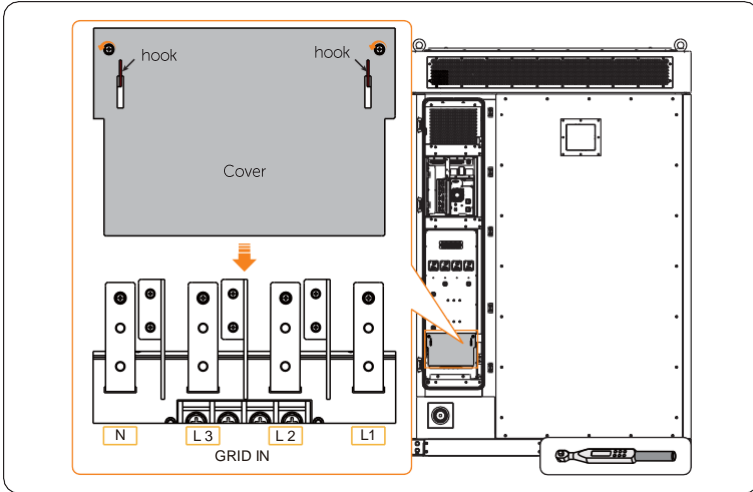

Figure 7-89 Removing cover

**NOTICE!**

- Please keep the M5 screws and cover properly.

**Step 11:** Unscrew the M8 screws using torque wrench, connect the assembled L1/L2/L3/ N wires to the wire interface, and then tighten them (torque:  $12\pm 1$  N-m). There are two options. **Option b** is recommended to connect. The ports of **option a** are regarded as reserved ports.

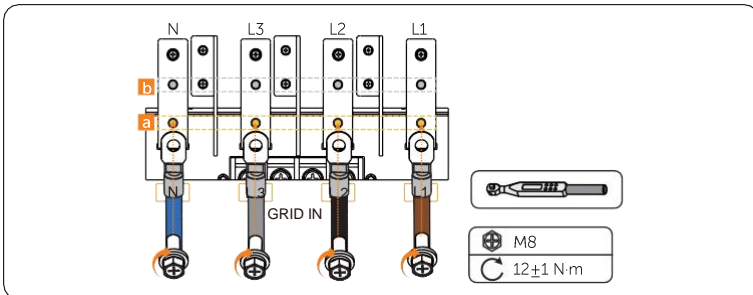

Figure 7-90 Connecting L1/L2/L3/N wires

**Step 12:** There are two M8 screws (a and b), and either of them can be connected to the PE wire. Hence, unscrew a M8 screw using a torque wrench, connect the assembled PE wire to the copper bar, and then tighten it (torque:  $12 \pm 1$  N·m).

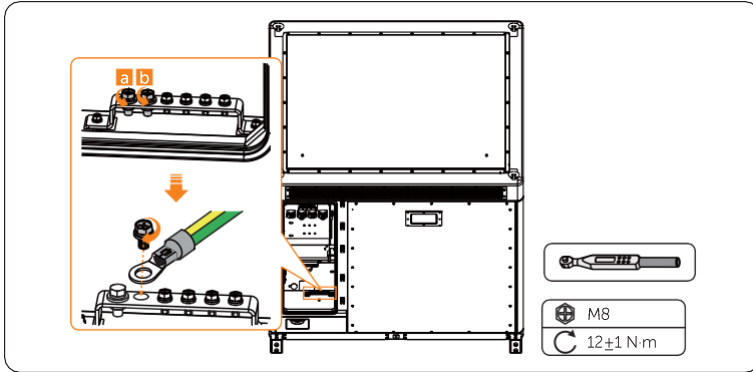

Figure 7-91 Connecting PE wire

**Step 13:** Reattach the cover over the hooks, and then correctly insert and tighten M5 screws (torque:  $2.0 \pm 0.2$  N·m).

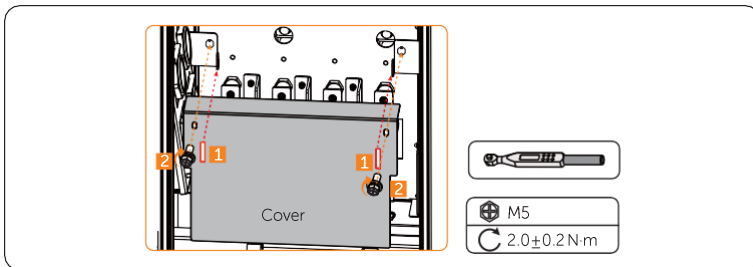

Figure 7-92 Reattaching cover

## 7.5 Fireproof Mud

After finishing wiring, the cable threading holes must be laid with fireproof mud.

**Step 1:** Lay the fireproof mud (Part G1) to plug the cable threading holes on both front and rear sides of the cabinet.

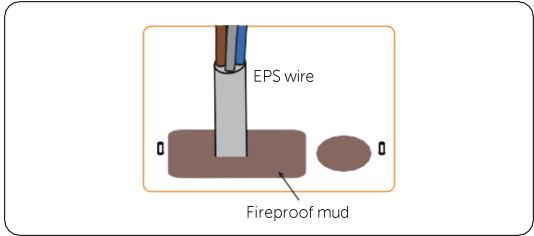

Figure 7-93 Plugging the cable threading hole on the front side

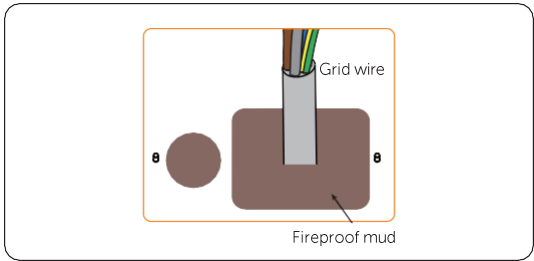

Figure 7-94 Plugging the cable threading hole on the rear side

### NOTICE!

**Notice for fireproofing mud:**

- Take out the fireproof mud delivered with the cabinet and knead it into a ball shape. In the case of the low temperature, place it into warm water, of which the temperature range is between 40°C and 70 °C, with its package until it is soft.
- Clean the area around the cable threading hole before sealing it.
- The fireproof mud should be evenly spread, embedded, or filled in the cable threading hole. If such a hole is too large, a fireproofing board can be placed to enhance fire protection before using the mud.
- The fireproof mud needs to be cured after sealing the cable threading hole. Prevent water from entering and colliding during curing.

## 7.6 Installation Procedure for Cable Cover

### NOTICE!

- Do not install the cable cover until the all the cables are wired.

**Step 1:** Unscrew M6 hexalobular screws, with a total of 8 screws (a1, a2, a3 and a4 for large cable cover, and b1, b2,b3 and b4 for small cable cover).

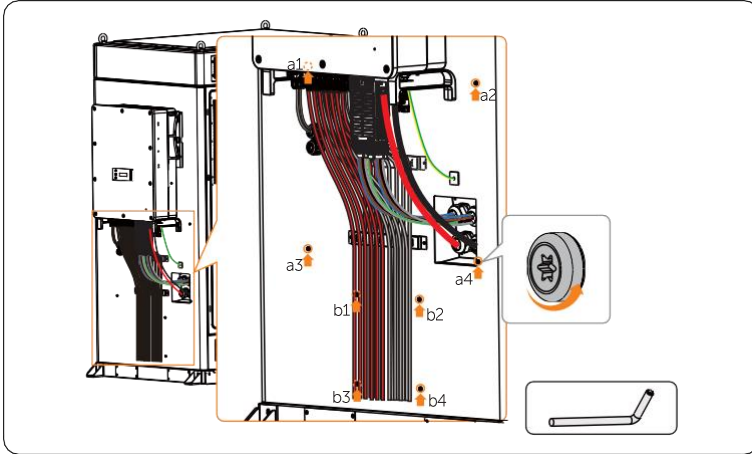

Figure 7-95 Unscrew M6 screws

### NOTICE!

- Keep these M6 screws properly.

**Step 2:** Attach the large cable cover (Part B1) to the cabinet, and insert and tighten the M6 hexalobular screws by using a hexalobular key.

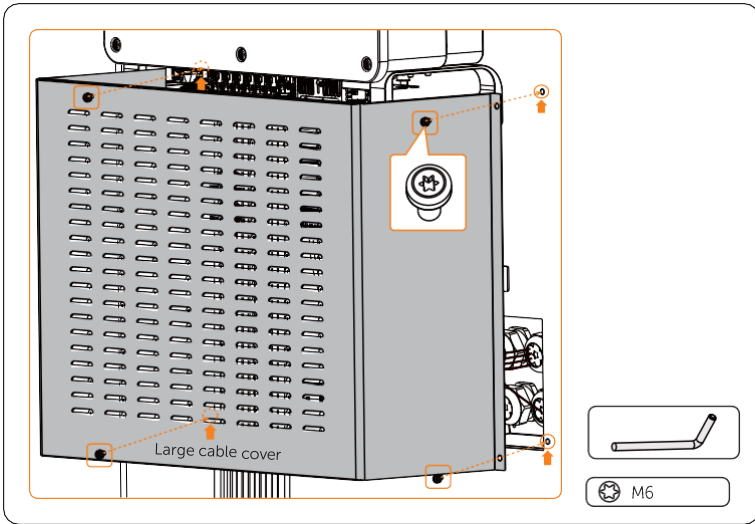

Figure 7-96 Attaching large cable cover

**Step 3:** Attach the small cable cover (Part C1) to the cabinet, and insert and tighten the M6 hexalobular screws by using a hexalobular key.

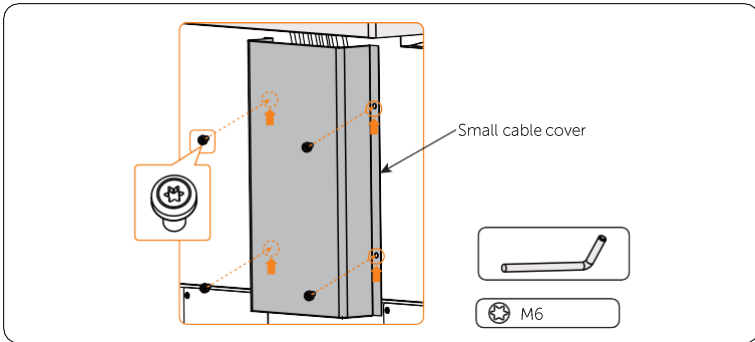

Figure 7-97 Attaching small cable cover

**NOTICE!**

- Must clean the materials, such as metal parts, screws, etc., in the cabinet after finishing wiring.
- It is recommended to seal off the gap between foundations after finishing wiring.

# 8 System Commissioning

---

## 8.1 Checking before Power-on

Ensure that all the cables connecting to the EPS and distribution box (grid side) are wired and securely fastened. For details, please refer to the following Table 8-1.

Table 8-1 Checklist

No.	Item	Description
1	Device appearance	<ul style="list-style-type: none"><li>• Check the device is in good condition, with a clean, non-peeling paint, and rust-free surface.</li><li>• Ensure that the labels on the device are clear and easy to read. If it is damaged, the label shall be replaced at once.</li></ul>
2	Installation	<ul style="list-style-type: none"><li>• The battery cabinet, inverter and other device (if any) are installed correctly and securely.</li><li>• All the screws are tightened.</li></ul>
3	Cable appearance	<ul style="list-style-type: none"><li>• Check that the cable jacket is in good condition.</li><li>• Check that the protective pipes are in good condition.</li></ul>
4	Cable connection	<ul style="list-style-type: none"><li>• Check that the cable connection position is consistent with the design principles.</li><li>• Ensure that the procedure for crimping terminals strictly observe the requirements, and the terminals are securely fastened.</li><li>• Check that the labels on the both sides of cables are clear, and the direction of both labels is the same.</li><li>• Check that all DC, AC cables, ground cable, communication cables and meter/CT of the inverter are connected correctly and securely</li><li>• Check that the external AC and DC connectors are connected; The connectors on the Grid and EPS terminal are connected correctly and securely.</li><li>• Check the unused terminals and ports of the inverter are locked by waterproof caps.</li><li>• Check that all photovoltaic panels are connected correctly and securely.</li></ul>

---

No.	Item	Description
5	Wiring	<ul style="list-style-type: none"> <li>• Ensure that the wiring procedure is consistent with the principle of separation of strong and weak electricity.</li> <li>• Ensure that the cables are neatly places.</li> <li>• Leave a little extra length for adjustments.</li> <li>• Keep cables tidy in the cabinet.</li> <li>• <b>Check if the grid connection voltage meets: <math>L1+N=220/230\text{ V}</math>, <math>L2+N=220/230\text{ V}</math>, <math>L3+N=220/230\text{ V}</math>, <math>L1+L2=380/400\text{ V}</math>, <math>L2+L3=380/400\text{ V}</math>, <math>L1+L3=380/400\text{ V}</math>.</b></li> </ul>
6	Copper bars in the battery pack	<ul style="list-style-type: none"> <li>• Check to make sure the copper bars are not deformed.</li> </ul>
7	Button/Switch	<ul style="list-style-type: none"> <li>• Check the distribution box's switch is "OFF".</li> <li>• Check the battery packs' switches are "OFF".</li> <li>• All the DC breakers and AC breakers are "OFF"</li> </ul>

## 8.2 Power ON

### NOTICE!

- Please check that the emergency stop button remains in the closed position before powering on.

Regarding the detailed location of the modules in the cabinet, see following figure.

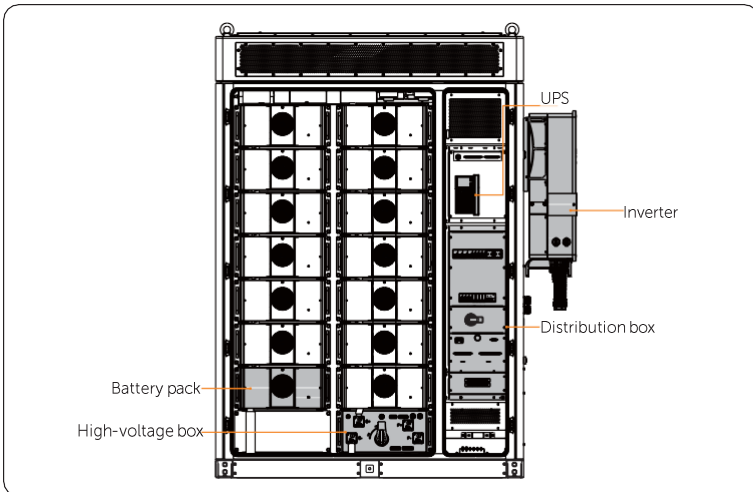

Figure 8-1 Location of modules

**Step 1:** Start the distribution box.

- » Rotate the switch on the distribution box 90° clockwise to "ON";
- » Flip up the "SPD MCB" breaker;
- » Flip up the "HVAC MCB" breaker;
- » Flip up the "EPS" breaker;
- » Flip up the "APS" breaker;
- » Flip up the "UPS" breaker.

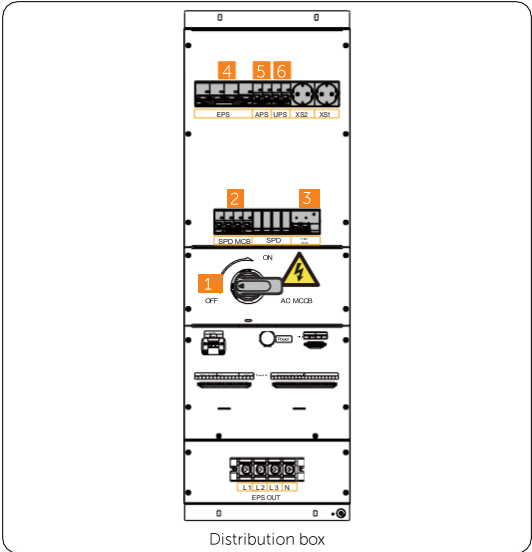

Figure 8-2 Starting sequence of distribution box

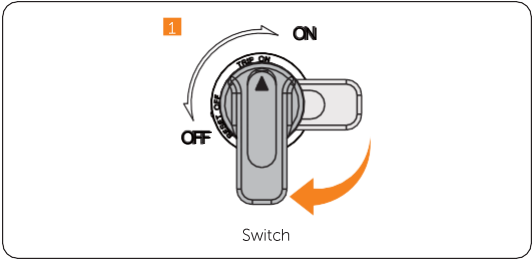

Figure 8-3 Rotating switch

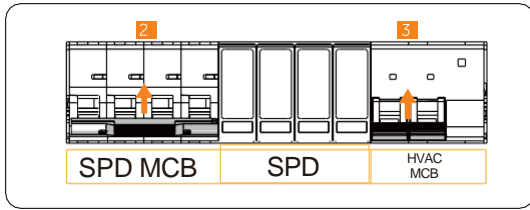

Figure 8-4 Flipping up breakers

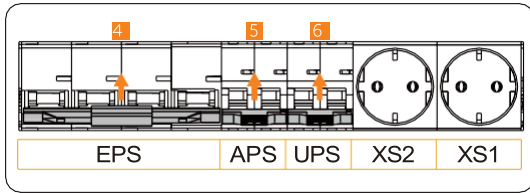

Figure 8-5 Flipping up breakers

**Step 2:** The startup sound on boot will be heard when holding and pressing the "Power on/off" button to start the UPS.

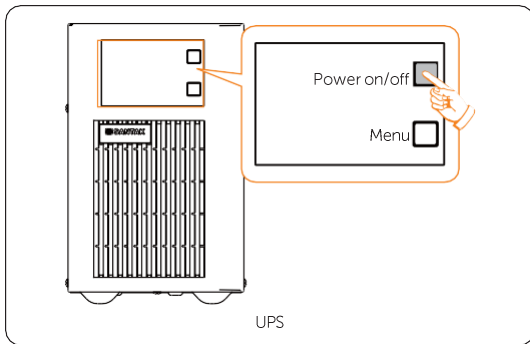

Figure 8-6 Holding and pressing button

**Step 3:** Rotate the disconnecter of the high-voltage box to "ON", and then gently press the power button. At the point, the LED light will come on green.

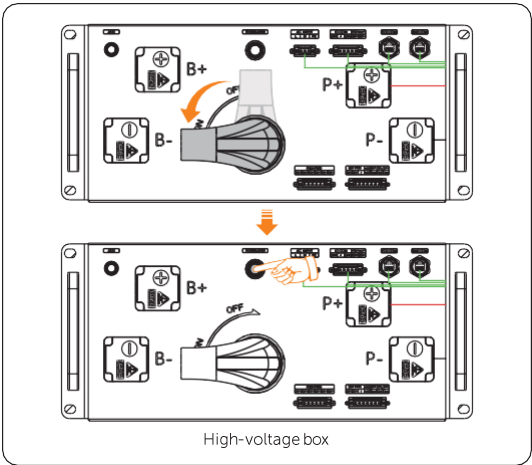

Figure 8-7 Starting the high-voltage box

**Step 4:** Close the door after the device has been started.

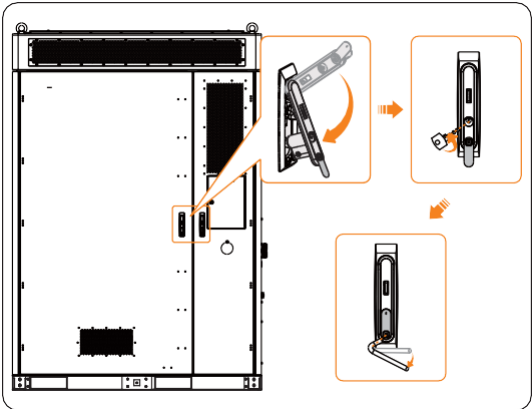

Figure 8-8 Closing the door

**NOTICE!**

- Please properly keep the key.

**Step 5:** Start the inverter.

- a. Turn on the AC breakers and check whether the LCD screen lights on.
  - » If the LCD screen is not on, turn off the AC breakers and check whether the Grid cable is connected correctly and securely.
- b. Switch on the inverter DC switch and check the LCD screen, check the PV voltage.
  - » If the PV voltage is 0, turn off the DC switch, pull out the PV connectors and then measure the voltage of the positive and negative PV port (in MPPT voltage range 160-950 V) or check whether the positive and negative poles of PV cables are reversed.
- c. Press and turn on the inverter system button.

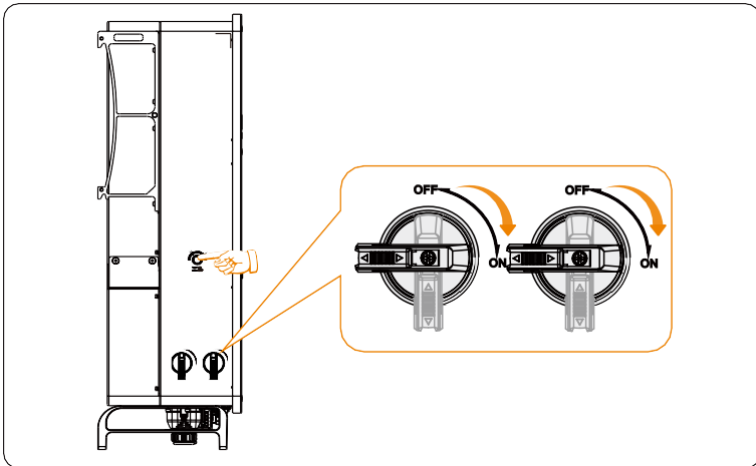

Figure 8-9 Starting the inverter

- d. Set **System ON/OFF** as ON status on the inverter screen, and the LCD displays waiting status.
- e. When the photovoltaic panels generate enough power or the battery supplies power, the inverter will start automatically. The inverter will go Waiting, Checking and Normal status in sequence.
- f. Check whether the meter/CT is correctly connected.
  - » If CT is connected, please perform the Meter/CT Check to check the correct connection through the setting path:  
**Menu>Setting>Advance Setting>Meter/CT Settings>Meter/CT Check**
  - » If meter is connected, please set the connection of Meter through the setting path: **Menu>Setting>Advance Setting>Meter/CT Settings.**

**NOTICE!**

- When the meter or CT is correctly connected, the meter/CT power displays on the METER/CT check interface; when the connection method is wrong, **Meter Fault** displays on this interface.

### 8.3 Checking after Power-on

- a. Check whether the system has any abnormal noise.
- b. Check whether the indicator lights report an error and check the system for alarm through the cabinet screen
- c. Check the running status of the system through the cabinet screen.

# 9 System Configuration

## 9.1 Operation on Inverter LCD

### 9.1.1 Introduction of Control Panel

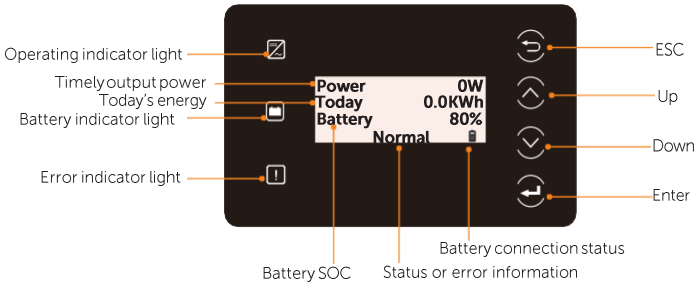





Figure 9-1 Control Panel

- In a normal state, the "Power", "Today" and "Battery" information will be displayed. You can press the keys to switch information.
- In an error state, the fault message and error code will be displayed, please refer to "11.3 Troubleshooting" for corresponding solutions.

Table 9-1 Definition of keys

Key	Definition
 ESC key	Exit from the current interface or function
 Up key	Move the cursor to the upper part or increase the value
 Down key	Move the cursor to the lower part or decrease the value
 Enter key	Confirm the selection

## 9.1.2 Introduction of Menu Interface

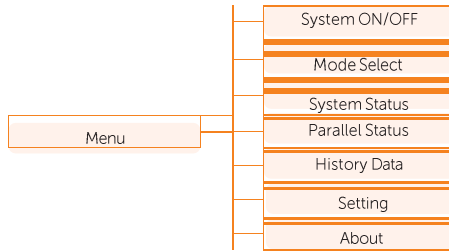

### NOTICE!

This section only introduces the necessary inverter related LCD operations after the system is powered on, for the complete operations on inverter LCD, please refer to the *X3-AELIO Series User Manual*.

## 9.1.3 Setting

Settings includes User Settings and Advanced Settings.

### User setting

Setting path: **Menu>Setting ("0 0 0 0 ")>User Setting**

### NOTICE!

The default password for **User Setting** is "0 0 0 0".

- Setting Date & Time

You can set the current date and time of the installation site.

The display format is "2023-06-16 14:00", in which the first four numbers represent the year (e.g. 2000~2099); the fifth and sixth numbers represent the month (e.g. 01~12); the seventh and the eighth numbers represent the date (e.g. 01~31). The remaining numbers represent the time.



- Setting Language

This inverter provides multiple languages for customers to choose, such as English, Deutsch, Francais, Polskie, Espanol, Português. The default language is English.

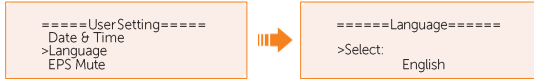

### Advance setting

Setting path: **Menu>Setting>Advance Setting**

NOTICE!
<p><b>Property losses or system damage due to unauthorized access to adjustable parameters.</b></p> <ul style="list-style-type: none"><li>• All the adjustable parameters including safety code, grid parameter, export control, etc can be modified under the permissions of installer password. Unauthorized use of the installer password by unauthorized persons can lead to incorrect parameters being input, resulting in power generation loss or violation of local regulation. Get the installer password from the dealer and never open the password to unauthorized person.</li></ul>

- Setting Safety Code

NOTICE!
<ul style="list-style-type: none"><li>• The inverter cannot be connected to the grid before the safety code is correctly set. If there is any doubt about your safety code where the inverter installed, please consult your dealer or SolaX service for details.</li><li>• The setup will vary from different safety codes.</li></ul>

Here you can set safety code according to different countries and grid-tied standards.

There are several standards to choose from, please refer to the LCD screen on the inverter. (May be changed or added without notice)

- » When you select safety code **CEI 0-21**, there will be additional **Self Test** option for setting under the path of **Menu>Setting>Advance Setting**.
- » When you select safety code **AS4777**, there will be additional **AS4777 Setting** option for **General Control** and **Export Control** under the path of **Menu>Setting>Advance Setting**.

- Setting Export Control

This function allows the inverter to control the amount of electricity output to the grid. The **User Value** set here must be less than the maximum value. If the user does not want to supply power to the grid, set **User Value** to "0".

### NOTICE!

- Under Safety Code AS4777, **Export Control** is in the path of **Advance Setting> AS4777 Setting**. You can set the **Soft Limit** and **Hard Limit** of **Export Control** to control the power output to grid. Please refer to X3-AELIO Series User Manual for details.

```
====ExportControl====
UserValue
300000W
```

## 9.2 Inverter Screen Cover Installation

After the inverter is well installed on the wall or on the cabinet, all cables are wired on the inverter, the process of powering on and powering off is checked and all necessary Settings are set on the inverter LCD screen, the inverter screen cover should be installed. Here below the inverter installed on the cabinet is taken for an example. Wall-mounting inverter shares the same screen cover installation method.

- Step 1:** Put the inverter screen cover (Part V2) on the inverter and secure the cover on the two sides of the inverter with M4\*10 screws (Part U2) (Torque:  $1.5 \pm 0.3 \text{ N}\cdot\text{m}$ ).

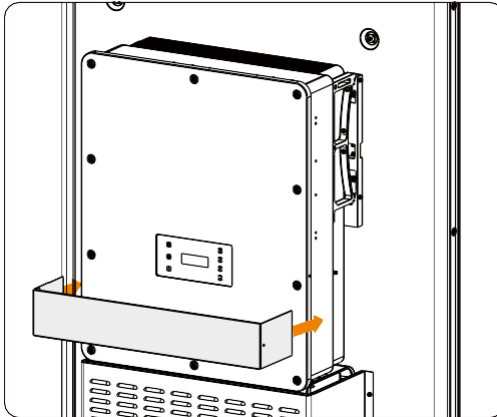

Figure 9-2 Putting the screen cover on the inverter

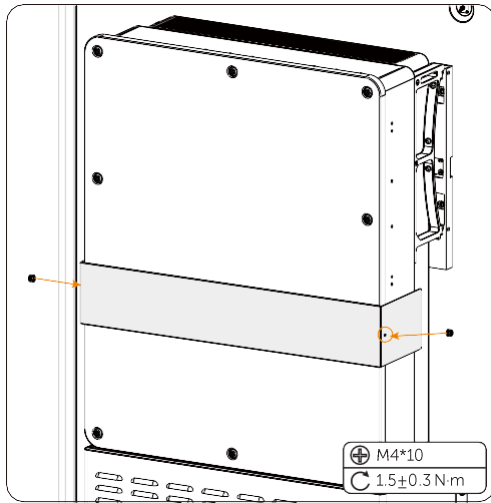

Figure 9-3 Securing the cover with the inverter

**Step 2:** Here is the well installed inverter screen cover.

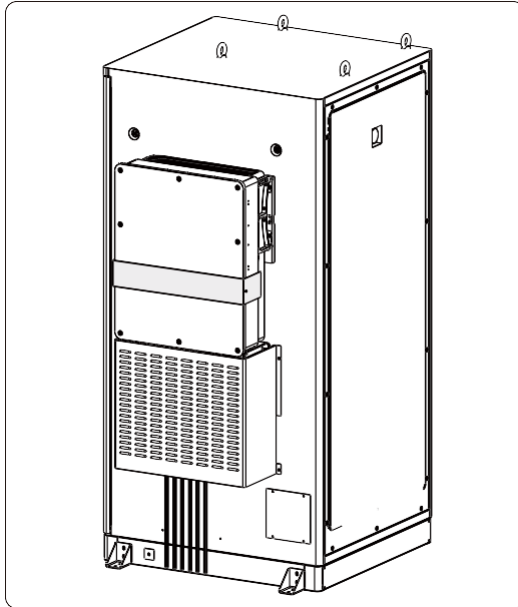

Figure 9-4 Well installed screen cover

### 9.3 Operation on Cabinet Screen

Gently and correctly guide the key (Part R) into the keyhole, and then turn it clockwise to unlock the screen door.

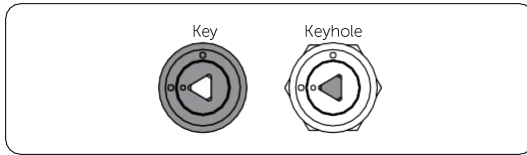

Figure 9-5 Correct position

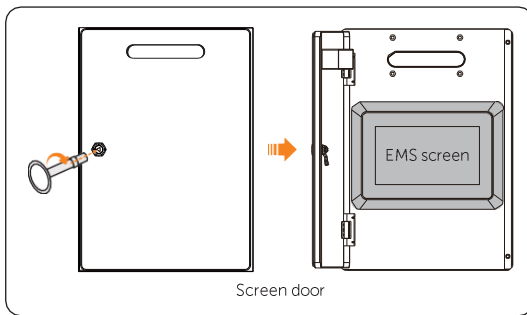

Figure 9-6 Unlocking screen door

#### 9.3.1 Logging in

On the login screen, enter the username and password, and then tap **Login**.

Admin and user accounts are supported.

Table 9-2 Account information

Username	Password	Remarks
Admin	EMS SN	The password cannot be modified
User	123456 by default	The password can be modified on EMS1000 webpage.

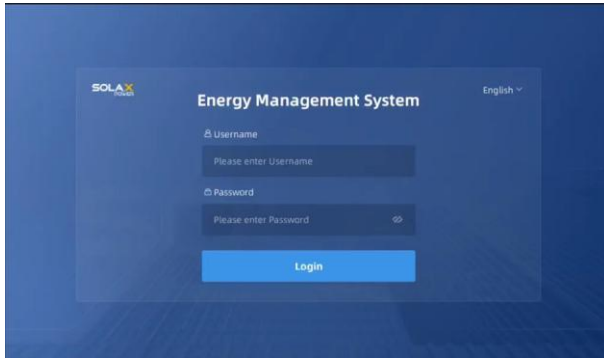

Figure 9-7 Logging in to the screen

### 9.3.2 Adding Inverter

#### NOTICE!

- This function is only available for Admin account.

Add the inverter to EMS1000 for unified system management.

**Step 1:** Log in to the screen, and then tap **Device**.

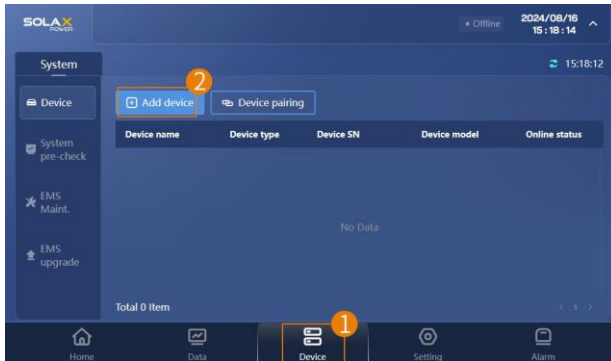

Figure 9-8 Adding inverter

**Step 2:** Tap **Add device**, set **Device type** to **Inverter** and **COM method** to **MODBUS TRU**, set the remaining parameters, and then tap **Confirm**.

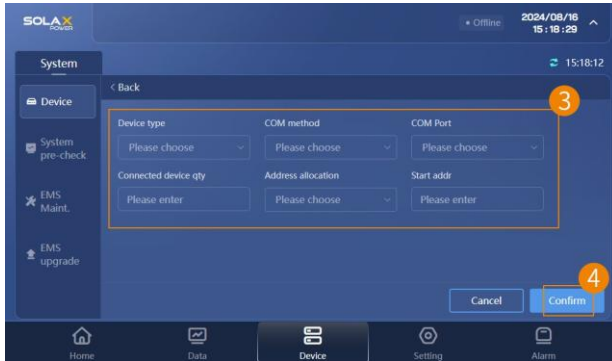

Figure 9-9 Setting parameters

Table 9-3 Parameter description

Parameter	Value Range	Description
COM Port	1-8	Number of RS485 terminal of EMS1000 that the inverter is connected to. For example, if the inverter is connected to the 8th RS485 terminal of the Device, the Serial Num is 8.
Connected device qty	1-20	Number of inverters that EMS1000 will be connected to. Up to 20 inverters can be connected.
Address allocation	<ul style="list-style-type: none"> <li>• Manual</li> <li>• Auto</li> </ul>	<ul style="list-style-type: none"> <li>• Auto: In this mode, EMS1000 will automatically assign and recognize an RTU address for your inverter.</li> <li>• Manual: In this mode, you will need to manually modify the Modbus address.</li> </ul>
Start addr	/	The minimal Modbus address For manual address allocation, enter the minimal address that is configured for the inverter; For auto address allocation, enter 1.

After the inverter is successfully added, the inverter and the meter that it is bound to will be displayed on the device list. If EMS1000 identifies other devices in the cabinet such as battery and IO module, these devices will also be displayed on the screen.

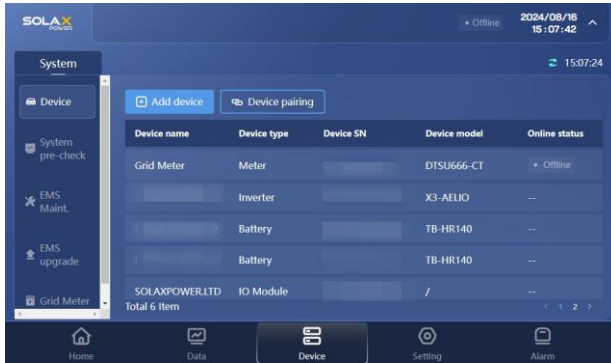

Figure 9-10 Adding inverter successfully

### 9.3.3 Pairing Inverter and Cabinet

#### NOTICE!

- This function is only available for Admin account.

You can pair the inverter and the cabinet for easier organization and management.

**Step 1:** Log in to the screen, and then tap **Device Pairing**.

The inverter, cabinet and related devices will pair automatically, and the pairing result will be displayed.

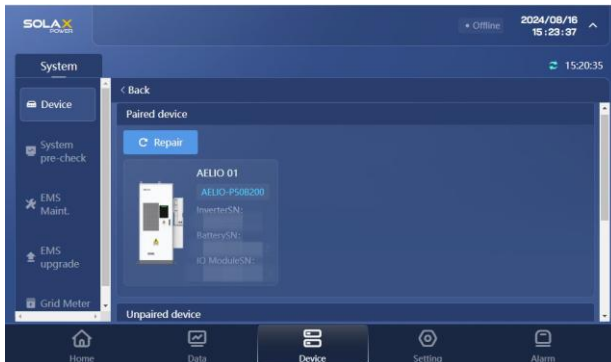

Figure 9-11 Pairing devices successfully

**Step 2:** Tap **Save and Pre-check** to save the pairing results.

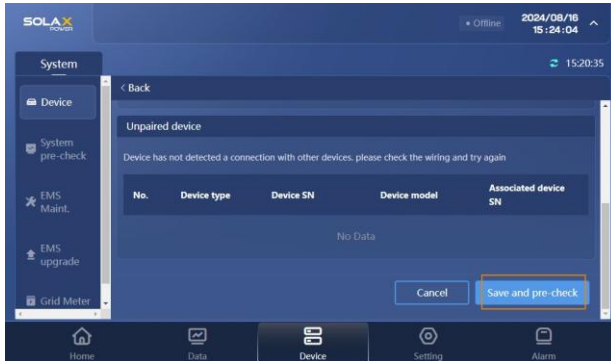

Figure 9-12 Save pairing

- Step 3:** On the pairing confirmation pop-up, tap **OK**  
The device list will be refreshed and displayed in architecture.

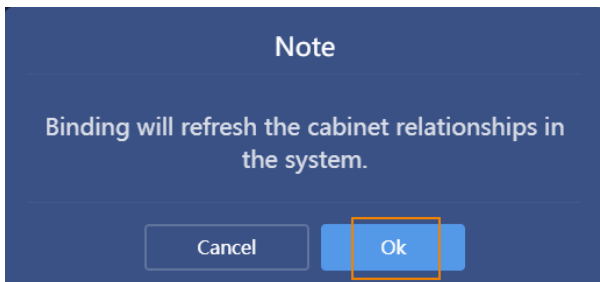

Figure 9-13 Confirming pairing

# 10 SolaXCloud App

---

## 10.1 Introduction of SolaXCloud

SolaxCloud is an intelligent management platform for home energy, which integrates energy efficiency monitoring, device management, data security communication and other integrated capabilities. While managing your home energy device, it helps you optimize the efficiency of electricity consumption and improve the revenue of power generation.

## 10.2 Operation Guide on SolaXCloud App

### 10.2.1 Downloading and Installing App

Method 1: Scan the QR code below to download the App.

The QR codes are also available on the login page of our official website ([www.solaxcloud.com](http://www.solaxcloud.com)).



Figure 10-1 QR code

Method 2: Search for **SolaXCloud** in Apple Store App or Google Play, and then download the App.

## 10.2.2 Operation on the SolaXCloud App

For instructions on the related operations, see the online documents on the SolaXCloud App.

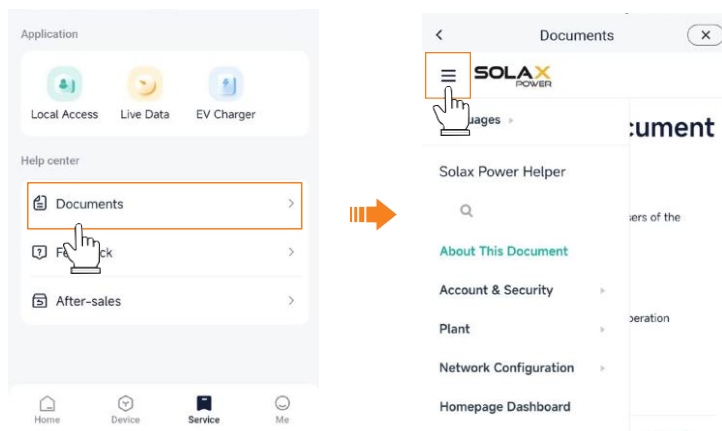

Figure 10-2 Online help on SolaXCloud

### NOTICE!

- The screen shots in this chapter correspond to the SolaXCloud App V6.4.1, which might change with version update and should be subject to the actual situations.

# 11 Troubleshooting and Maintenance

## 11.1 Power Off



- Check whether the system is still running before power off. Do not power off if the device is "under load".

Regarding the detailed location of the modules in the cabinet, please refer to "Figure 8-1 Location of modules".

There are two circumstances: 1. Normal power off; 2. Emergency power off.

### Normal Power Off

**Step 1:** Inverter power off.

- a. Set **OFF** in the **System ON/OFF** on the inverter LCD screen.
- b. Turn off the inverter system button.
- c. Set the DC switch1 and DC switch2 to "OFF".

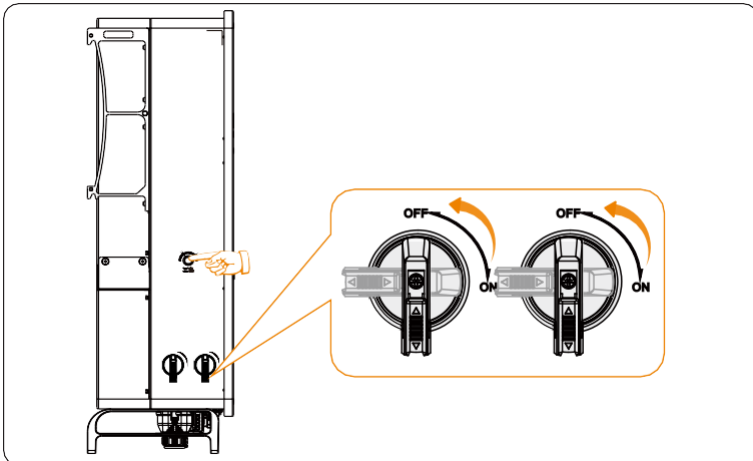

Figure 11-3 Shutting down the inverter

**Step 2:** Open the front doors.

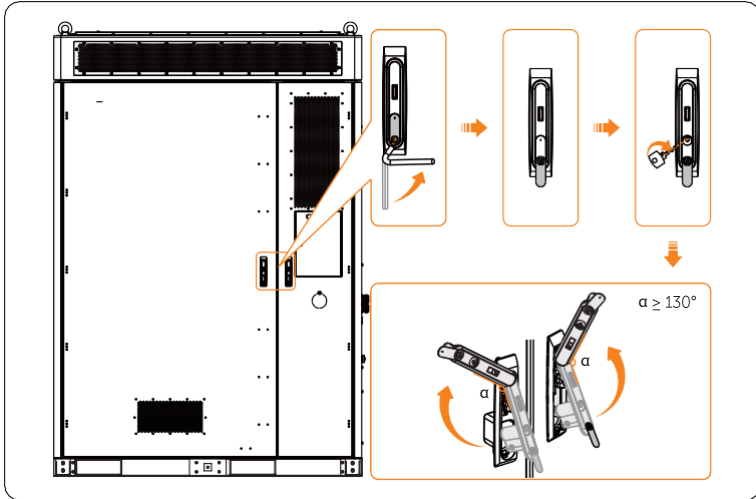

Figure 11-1 Opening front doors

**Step 3:** Shut down the distribution box.

- » Flip down the "lightning protection breaker (SPD MCB)";
- » Flip down the "air conditioner/liquid cooling unit on/off breaker (HVAC MCB)";
- » Flip down the "auxiliary power breaker of high-voltage box (APS)";
- » Flip down the UPS breaker;
- » Rotate the switch on the distribution box 90° counter-clockwise to "OFF".

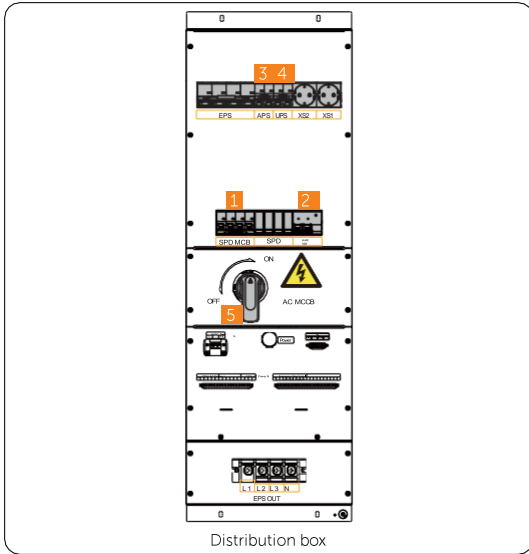

Figure 11-2 Shutting down sequence of distribution box

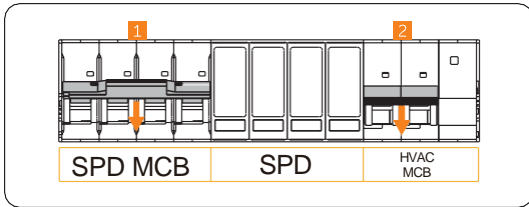

Figure 11-3 Flipping down breakers

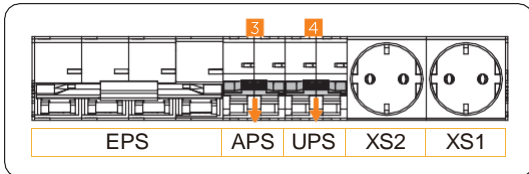

Figure 11-4 Flipping down breakers

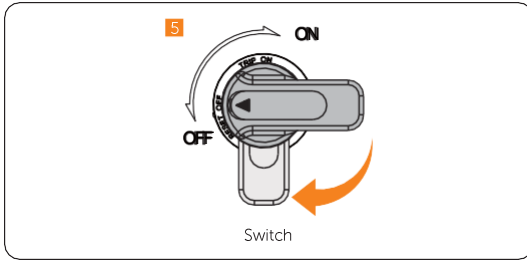

Figure 11-5 Rotating switch

**Step 4:** Gently press the power button, and rotate the disconnecter of the high-voltage box to "OFF".

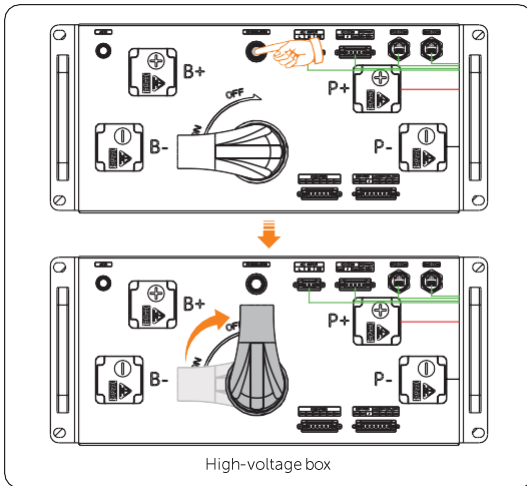

Figure 11-6 Shutting down the high-voltage box

**Step 5:** Hold and press the "Power on/off" button to power off the UPS.

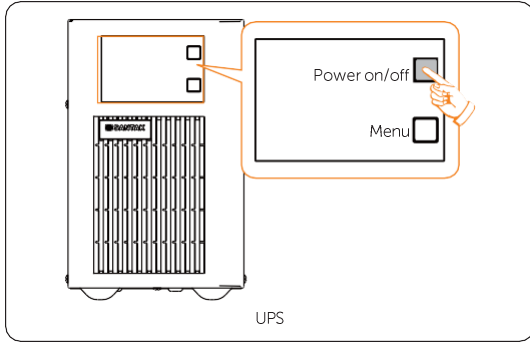

Figure 11-7 Holding and pressing button

 **WARNING!**

- The device may still have power and heat after turning off, which may cause electric shock and personal injuries. Therefore, please allow it to cool for at least 5 minutes and wear PPE before conducting maintenance.

## Emergency Power Off

### WARNING!

- Do not press the emergency stop button except for emergencies.
- Some modules inside the cabinet may still have power after pressing the emergency stop button, therefore, non-professionals are not allowed to operate them.

**Step 1:** Rotate the cover

**Step 2:** Press the emergency stop button.

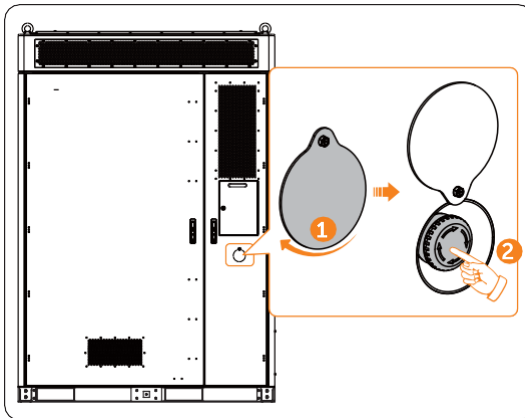

Figure 11-8 Pressing emergency stop button

### NOTICE!

**If it has been pressed, the emergency stop button must be reset before starting the device. The reset steps are shown as follows:**

- Rotate the cover;
- Rotate the button according to the arrow direction shown on the button. Then the button will spring back to its original position.

## 11.2 Operation of Lockable DC Switch (for Australia Version Only)

### NOTICE!

- The Australian version DC switch is a lockable DC switch to prevent accidental switching on during maintenance, the lock needs to be prepared by the user.

The lockable DC switch includes 3 states: ON, OFF, and OFF+Lock. The DC switch is in the OFF state by default.

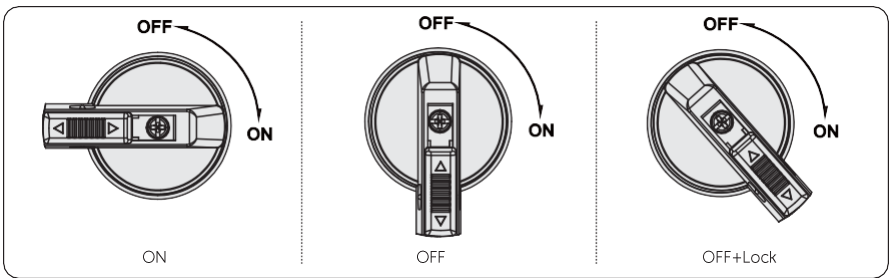

- Turn on the DC switch: rotate the DC switch from OFF state to ON state.

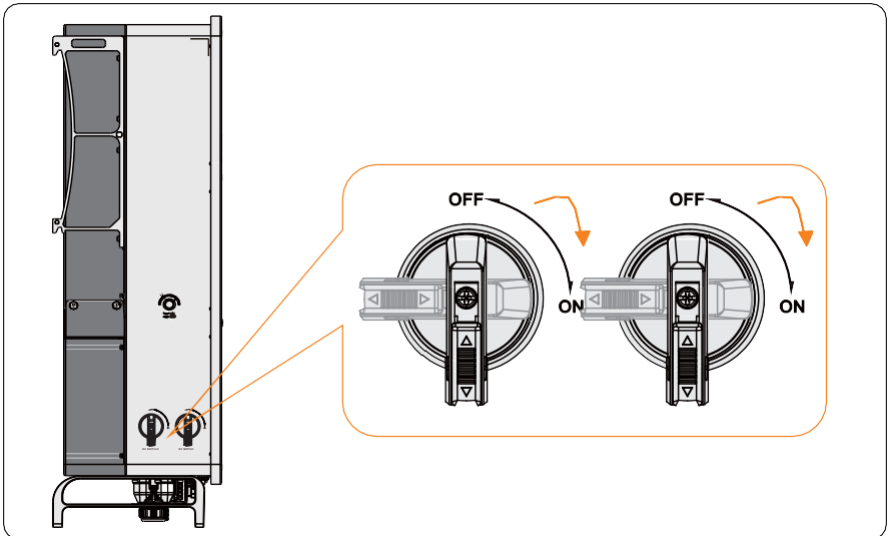

- Turn off the DC switch: rotate the DC switch from ON state to OFF state.

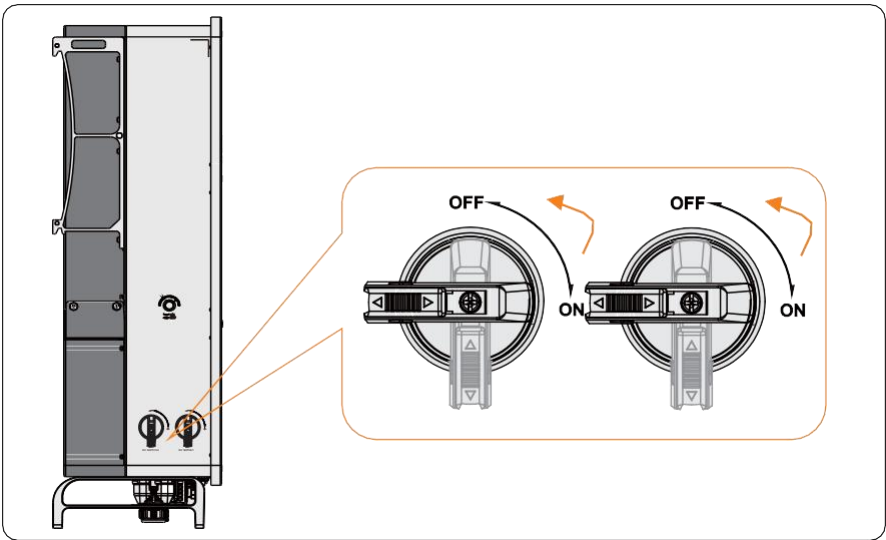

- Lock the DC switch
  - a. Rotate the DC switch to OFF state, then rotate the DC switch to the left side;
  - b. Push the position indicated by the arrow upward (as shown in the diagram below).
  - c. (Optional) After pushing the position upward, choose to lock the DC switch with a lock.

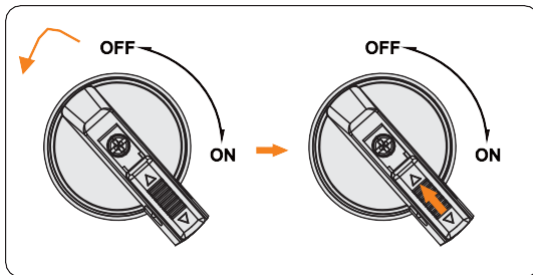

- Unlock the DC switch
  - a. Remove the lock. (If any);
  - b. Push the position indicated by the arrow down (as shown in the diagram below);
  - c. Wait for it to return to OFF state.

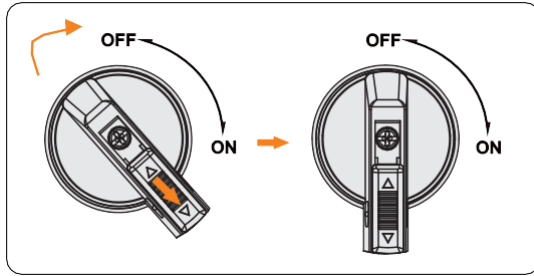

## 11.3 Troubleshooting

### 11.3.1 Battery Cabinet Troubleshooting

This section lists the possible problems with the device, and provides information and procedures for identifying and resolving them. In case of any errors, check for the warnings or error messages on the system control panel or App, and then refer to the suggestions below. For further assistance, contact SolaX Customer Service. Please provide the model and SN of the cabinet, and be prepared to describe the system installation details.

Table 11-1 Troubleshooting list

Fault	Description and Diagnosis
UCellHi_4	Single Cell Overvoltage Category IV <ul style="list-style-type: none"> <li>• Do not power on, and the charging current is limited to 0 A. If the relay does not receive a power-off instruction from the inverter, it will be turned off forcefully after 3 seconds.</li> <li>• Or contact SolaX for help.</li> </ul>
UCellHi_5	Single Cell Overvoltage Category V <ul style="list-style-type: none"> <li>• Do not power on, and the charging current is limited to 0 A. If the relay does not receive a power-off instruction from the inverter, it will be turned off forcefully after 1 second.</li> <li>• Or contact SolaX for help.</li> </ul>
UCellLow_4	Single Cell Undervoltage Category IV <ul style="list-style-type: none"> <li>• Do not power on, and the charging current is limited to 0 A. If the relay does not receive a power-off instruction from the inverter, it will be turned off forcefully after 3 seconds.</li> <li>• Or contact SolaX for help.</li> </ul>

Fault	Description and Diagnosis
UCellLow_5	<p data-bbox="334 237 692 260">Single Cell Undervoltage Category V</p> <ul data-bbox="334 272 951 371" style="list-style-type: none"> <li data-bbox="334 272 951 347">• Do not power on, and the charging current is limited to 0 A. If the relay does not receive a power-off instruction from the inverter, it will be turned off forcefully after 3 seconds.</li> <li data-bbox="334 352 609 371">• Or contact SolaX for help.</li> </ul>
UCellDiff	<p data-bbox="334 384 563 406">Voltage difference fault</p> <ul data-bbox="334 419 609 442" style="list-style-type: none"> <li data-bbox="334 419 609 442">• Or contact SolaX for help.</li> </ul>
HVBOver_4	<p data-bbox="334 456 725 478">Overvoltage category IV of total voltage</p> <ul data-bbox="334 491 932 590" style="list-style-type: none"> <li data-bbox="334 491 932 566">• The charging current is limited to 0 A. If the relay does not receive a power-off instruction from the inverter, it will be turned off forcefully after 3 seconds.</li> <li data-bbox="334 571 609 590">• Or contact SolaX for help.</li> </ul>
HVBOver_5	<p data-bbox="334 604 719 627">Overvoltage category V of total voltage</p> <ul data-bbox="334 639 932 738" style="list-style-type: none"> <li data-bbox="334 639 932 715">• The charging current is limited to 0 A. If the relay does not receive a power-off instruction from the inverter, it will be turned off forcefully after 1 second.</li> <li data-bbox="334 719 609 738">• Or contact SolaX for help.</li> </ul>
HVBLow	<p data-bbox="334 753 741 775">Undervoltage category IV of total voltage</p> <ul data-bbox="334 788 932 887" style="list-style-type: none"> <li data-bbox="334 788 932 863">• The charging current is limited to 0 A. If the relay does not receive a power-off instruction from the inverter, it will be turned off forcefully after 1 second.</li> <li data-bbox="334 868 609 887">• Or contact SolaX for help.</li> </ul>
HVBLow	<p data-bbox="334 901 736 924">Undervoltage category V of total voltage</p> <ul data-bbox="334 936 932 1035" style="list-style-type: none"> <li data-bbox="334 936 932 1011">• The charging current is limited to 0 A. If the relay does not receive a power-off instruction from the inverter, it will be turned off forcefully after 1 second.</li> <li data-bbox="334 1016 609 1035">• Or contact SolaX for help.</li> </ul>
PosRlyAdh	<p data-bbox="334 1059 719 1082">Sticking contacts of main positive relay</p> <ul data-bbox="334 1094 932 1193" style="list-style-type: none"> <li data-bbox="334 1094 932 1169">• The charging current is limited to 0 A. If the relay does not receive a power-off instruction from the inverter, it will be turned off forcefully after 1 second.</li> <li data-bbox="334 1174 609 1193">• Or contact SolaX for help.</li> </ul>
PosRlyOpen	<p data-bbox="334 1214 672 1236">Open circuit of main positive relay</p> <ul data-bbox="334 1249 932 1348" style="list-style-type: none"> <li data-bbox="334 1249 932 1324">• The charging current is limited to 0 A. If the relay does not receive a power-off instruction from the inverter, it will be turned off forcefully after 1 second.</li> <li data-bbox="334 1329 609 1348">• Or contact SolaX for help.</li> </ul>

Fault	Description and Diagnosis
TempHigh	<p>Overtemperature fault</p> <ul style="list-style-type: none"> <li>• The charging current is limited to 0 A. If the relay does not receive a power-off instruction from the inverter, it will be turned off forcefully after 1 second.</li> <li>• Or contact SolaX for help.</li> </ul>
TLineFt_1	<p>Temperature sampling fault level 1</p> <ul style="list-style-type: none"> <li>• Check if the temperature sensor is short-circuited.</li> <li>• Or contact SolaX for help.</li> </ul>
TLineFt_4	<p>Temperature sampling fault level 4</p> <ul style="list-style-type: none"> <li>• The charging current is limited to 0 A. If the relay does not receive a power-off instruction from the inverter, it will be turned off forcefully after 3 seconds.</li> <li>• Or contact SolaX for help.</li> </ul>
TempLow	<p>Low-temperature fault</p> <ul style="list-style-type: none"> <li>• The charging current is limited to 0 A. If the relay does not receive a power-off instruction from the inverter, it will be turned off forcefully after 1 second.</li> <li>• Or contact SolaX for help.</li> </ul>
DsgOver_4	<p>Discharge overcurrent fault level 4</p> <ul style="list-style-type: none"> <li>• The charging current is limited to 0 A. If the relay does not receive a power-off instruction from the inverter, it will be turned off forcefully after 3 seconds.</li> <li>• Or contact SolaX for help.</li> </ul>
DsgOver_5	<p>Discharge overcurrent fault level 5</p> <ul style="list-style-type: none"> <li>• The charging current is limited to 0 A. If the relay does not receive a power-off instruction from the inverter, it will be turned off forcefully after 1 second.</li> <li>• Or contact SolaX for help.</li> </ul>
ChgOver_4	<p>Charge overcurrent fault level 4</p> <ul style="list-style-type: none"> <li>• The charging current is limited to 0 A. If the relay does not receive a power-off instruction from the inverter, it will be turned off forcefully after 3 seconds.</li> <li>• Or contact SolaX for help.</li> </ul>
ChgOver_5	<p>Charge overcurrent fault level 5</p> <ul style="list-style-type: none"> <li>• The charging current is limited to 0 A. If the relay does not receive a power-off instruction from the inverter, it will be turned off forcefully after 1 second.</li> <li>• Or contact SolaX for help.</li> </ul>

Fault	Description and Diagnosis
ICOMFault	<p>Internal communication fault</p> <ul style="list-style-type: none"> <li>Do not power on, and the charging current is limited to 0 A. If the relay does not receive a power-off instruction from the inverter, it will be turned off forcefully after 1 second.</li> <li>Or contact SolaX for help.</li> </ul>
OCOMFault	<p>External communication fault</p> <ul style="list-style-type: none"> <li>Do not power on, and the charging current is limited to 0 A. If the relay does not receive a power-off instruction from the inverter, it will be turned off forcefully after 1 second.</li> <li>Or contact SolaX for help.</li> </ul>
MCOMFault	<p>Intermediate network communication fault</p> <ul style="list-style-type: none"> <li>Do not power on, and the charging current is limited to 0 A.</li> <li>Or contact SolaX for help.</li> </ul>
UCellLineOpenFlt	<p>Voltage sampling fault</p> <ul style="list-style-type: none"> <li>The charging current is limited to 0 A. If the relay does not receive a power-off instruction from the inverter, it will be turned off forcefully after 1 second.</li> <li>Or contact SolaX for help.</li> </ul>
VoltSensorFlt	<p>Voltage sensor fault</p> <ul style="list-style-type: none"> <li>The charging current is limited to 0 A. If the relay does not receive a power-off instruction from the inverter, it will be turned off forcefully after 1 second.</li> <li>Or contact SolaX for help.</li> </ul>
CurrSensorFlt	<p>Current sensor fault</p> <ul style="list-style-type: none"> <li>Contact SolaX for help.</li> </ul>
NegRlyAdh	<p>Sticking contacts of main negative relay</p> <ul style="list-style-type: none"> <li>Restart the device.</li> <li>Or contact SolaX for help.</li> </ul>
NegRlyOpen	<p>Open circuit of main negative relay</p> <ul style="list-style-type: none"> <li>Restart the device.</li> <li>Or contact SolaX for help.</li> </ul>
FlashFlt	<p>Flash fault</p> <ul style="list-style-type: none"> <li>Check if the external Flash communication is normal.</li> <li>Or contact SolaX for help.</li> </ul>
ChgReqFlt	<p>Charging request fault</p> <ul style="list-style-type: none"> <li>Check the device is properly charged.</li> <li>Or contact SolaX for help.</li> </ul>

Fault	Description and Diagnosis
InsFlt	<p>Insulation fault</p> <ul style="list-style-type: none"> <li>• The charging current is limited to 0 A. If the relay does not receive a power-off instruction from the inverter, it will be turned off forcefully after 1 second.</li> <li>• Or contact SolaX for help.</li> </ul>
SOCLowFlt	<p>Low SOC</p> <ul style="list-style-type: none"> <li>• Check if the device is running out of power.</li> <li>• Or contact SolaX for help.</li> </ul>
PreChgFailFlt	<p>External short-circuit fault</p> <ul style="list-style-type: none"> <li>• The charging current is limited to 0 A. If the relay does not receive a power-off instruction from the inverter, it will be turned off forcefully after 1 second.</li> <li>• Or contact SolaX for help.</li> </ul>
AFEProtectFlt	<p>Battery's hardware protection fault</p> <ul style="list-style-type: none"> <li>• The charging current is limited to 0 A. If the relay does not receive a power-off instruction from the inverter, it will be turned off forcefully after 1 second.</li> <li>• Or contact SolaX for help.</li> </ul>
SelfCheckFlt	<p>Self-test fault</p> <ul style="list-style-type: none"> <li>• The charging current is limited to 0 A. If the relay does not receive a power-off instruction from the inverter, it will be turned off forcefully after 1 second.</li> <li>• Or contact SolaX for help.</li> </ul>
LinkerTempHiFlt_3	<p>Fault on overtemperature of high-voltage connector</p> <ul style="list-style-type: none"> <li>• Check whether the charge/discharge current is over 50% of rated charge/discharge current.</li> <li>• Or contact SolaX for help.</li> </ul>
LinkerTempHiFlt_5	<p>Fault on overtemperature of high-voltage connector</p> <ul style="list-style-type: none"> <li>• Check whether the charge/discharge current is over 50% of rated charge/discharge current.</li> <li>• Or contact SolaX for help.</li> </ul>
BatLinkerTempHi_5	<p>High-temperature fault of pole</p> <ul style="list-style-type: none"> <li>• The charging current is limited to 0 A. If the relay does not receive a power-off instruction from the inverter, it will be turned off forcefully after 3 seconds.</li> <li>• Or contact SolaX for help.</li> </ul>
FanFault	<p>Fan fault</p> <ul style="list-style-type: none"> <li>• Check whether any foreign objects stick to the fan.</li> <li>• Contact SolaX for help.</li> </ul>

Fault	Description and Diagnosis
FuseSt	Fuse fault <ul style="list-style-type: none"> <li>• Contact SolaX for help.</li> </ul>
DCSwitch	DC switch fault <ul style="list-style-type: none"> <li>• Contact SolaX for help.</li> </ul>

### 11.3.2 Inverter Troubleshooting

This section contains information and procedures for resolving possible problems with the inverter, and provides the troubleshooting tips to identify and solve most problems that may occur. Please check the warning or fault information on the system control panel or on the App and read the suggested solutions below when error occurs. Contact SolaX Customer Service for further assistance. Please be prepared to describe the details of your system installation and provide the model and serial number of the inverter.

Table 11-1 Troubleshooting list

Error Code	Fault	Descriptions and Diagnosis
IE 01	TZ Protect Fault	Overcurrent fault. <ul style="list-style-type: none"> <li>• Wait for a while to check if it returns to normal.</li> <li>• Disconnect PV+ PV- and batteries, reconnect.</li> <li>• If the system is in off-grid state, check if the power of EPS loads exceeds the maximum limit of the system or exceeds the current power supply of battery.</li> <li>• If the system fails to restore to its normal state, please contact SolaX for help.</li> </ul>
IE 02	Grid Lost Fault	Grid Lost Fault <ul style="list-style-type: none"> <li>• Check the grid connection status</li> <li>• Or contact SolaX for help.</li> </ul>
IE 03	Grid Volt Fault	Power grid voltage overrun <ul style="list-style-type: none"> <li>• Wait a moment, if the utility returns to normal, the system will reconnect.</li> <li>• Please check if the grid voltage is within normal range.</li> <li>• Or contact SolaX for help.</li> </ul>
IE 04	Grid Freq Fault	Grid overfrequency <ul style="list-style-type: none"> <li>• Wait a moment, If the utility returns to normal, the system reconnects.</li> <li>• Or contact SolaX for help.</li> </ul>

Error Code	Fault	Descriptions and Diagnosis
IE 05	PV Volt Fault	<p>PV overvoltage</p> <ul style="list-style-type: none"> <li>• Check the output voltage of the PV panel.</li> <li>• Check if the DC switch is OFF.</li> <li>• Or contact SolaX for help.</li> </ul>
IE 06	Bus Volt Fault	<ul style="list-style-type: none"> <li>• Press the <b>ESC</b> key to restart the inverter.</li> <li>• Check if the PV input open circuit voltage is in the normal range.</li> <li>• Check if the power of half-wave load exceeds the system limit.</li> <li>• Or contact SolaX for help.</li> </ul>
IE 07	Bat Volt Fault	<p>Battery voltage fault</p> <ul style="list-style-type: none"> <li>• Check if the battery input voltage is within normal range</li> <li>• Or contact SolaX for help.</li> </ul>
IE 08	AC10mins Volt	<p>Grid voltage out of range in the last 10 minutes.</p> <ul style="list-style-type: none"> <li>• The system will return to normal if the grid returns to normal.</li> <li>• Or contact SolaX for help.</li> </ul>
IE 09	DCI OCP Fault	<p>DCI overcurrent protection fault.</p> <ul style="list-style-type: none"> <li>• Wait for a while to check if it's back to normal.</li> <li>• Or contact SolaX for help.</li> </ul>
IE 10	DCV OVP Fault	<p>DCV EPS(Off-grid) overvoltage protection fault.</p> <ul style="list-style-type: none"> <li>• Wait for a while to check if it's back to normal.</li> <li>• Or contact SolaX for help.</li> </ul>
IE 11	SW OCP Fault	<p>Software detection of overcurrent Fault.</p> <ul style="list-style-type: none"> <li>• Wait for a while to check if it's back to normal.</li> <li>• Shut down photovoltaic, battery and grid connections.</li> <li>• Or contact SolaX for help.</li> </ul>
IE 12	RC OCP Fault	<p>Overcurrent protection fault.</p> <ul style="list-style-type: none"> <li>• Check the impedance of DC input and AC output.</li> <li>• Wait for a while to check if it's back to normal.</li> <li>• Or contact SolaX for help.</li> </ul>
IE 13	Isolation Fault	<p>Insulation fault</p> <ul style="list-style-type: none"> <li>• Please check the wire insulation for damage.</li> <li>• Wait for a while to check if it's back to normal.</li> <li>• Or contact SolaX for help.</li> </ul>
IE 14	Temp Over Fault	<p>Temperature out of range</p> <ul style="list-style-type: none"> <li>• Check if the ambient temperature exceeds the limit.</li> <li>• Or contact SolaX for help.</li> </ul>

Error Code	Fault	Descriptions and Diagnosis
IE 15	Bat Con Dir Fault	<ul style="list-style-type: none"> <li>Battery direction fault</li> <li>Check if the battery lines are connected in the opposite direction.</li> <li>Or ask for help from the installer if it can not return to normal.</li> </ul>
IE 16	EPS Overload	<p>EPS(Off-grid) overload fault</p> <ul style="list-style-type: none"> <li>Shutdown the high-power device and press the <b>ESC</b> key to restart the inverter.</li> <li>Or contact SolaX for help if it can not return to normal.</li> </ul>
IE 17	Overload Fault	<p>On-grid mode overload fault</p> <ul style="list-style-type: none"> <li>Shutdown the high-power device and press the <b>ESC</b> key to restart the inverter.</li> <li>Or contact SolaX for help if it can not return to normal.</li> </ul>
IE 18	BatPowerLow	<p>Bat Power Low</p> <ul style="list-style-type: none"> <li>Shutdown the high-power device and press the <b>ESC</b> key to restart the inverter.</li> <li>Please charge the battery to a level higher than the protection capacity or protection voltage.</li> </ul>
IE 19	BMS Lost	<p>Battery communication lost</p> <ul style="list-style-type: none"> <li>Check that the communication cable between the battery and the inverter are properly connected.</li> <li>Or contact SolaX for help if it can not return to normal.</li> </ul>
IE 20	Fan Fault	<p>Fan Fault</p> <ul style="list-style-type: none"> <li>Check for any foreign matter that may have caused the fan not to function properly.</li> <li>Or contact SolaX for help if it can not return to normal.</li> </ul>
IE 21	Low TempFault	<p>Low temperature fault.</p> <ul style="list-style-type: none"> <li>Check if the ambient temperature is too low.</li> <li>Or contact SolaX for help if it can not return to normal.</li> </ul>
IE 25	InterComFault	<p>Inter_Com_Fault</p> <ul style="list-style-type: none"> <li>Restart the inverter.</li> <li>Or contact SolaX for help if it can not return to normal.</li> </ul>
IE 26	INV EEPROM	<p>Inverter EEPROM Fault.</p> <ul style="list-style-type: none"> <li>Shut down photovoltaic, battery and grid, reconnect.</li> <li>Or contact SolaX for help if it can not return to normal.</li> </ul>

Error Code	Fault	Descriptions and Diagnosis
IE 27	RCD Fault	Residual Current Device fault <ul style="list-style-type: none"> <li>• Check the impedance of DC input and AC output.</li> <li>• Disconnect PV + PV - and batteries, reconnect.</li> <li>• Or contact SolaX for help if it can not return to normal.</li> </ul>
IE 28	Grid Relay Fault	Electrical relay fault <ul style="list-style-type: none"> <li>• Disconnect PV+ PV- grid and batteries and reconnect.</li> <li>• Or contact SolaX for help if it can not return to normal.</li> </ul>
IE 29	EPS Relay	EPS(Off-grid) relay fault <ul style="list-style-type: none"> <li>• Disconnect PV+ ,PV-, grid and batteries and reconnect.</li> <li>• Or contact SolaX for help if it can not return to normal.</li> </ul>
IE 30	PV ConnDirFault	PV direction fault <ul style="list-style-type: none"> <li>• Check if the PV input lines are connected in the opposite direction.</li> <li>• Or contact SolaX for help if it can not return to normal.</li> </ul>
IE 31	Battery Relay	Charge relay fault <ul style="list-style-type: none"> <li>• Press the <b>ESC</b> key to restart the inverter.</li> <li>• Or contact SolaX for help if it can not return to normal.</li> </ul>
IE 32	Earth Relay	EPS(Off-grid) earth relay fault <ul style="list-style-type: none"> <li>• Press the <b>ESC</b> key to restart the inverter.</li> <li>• Or contact SolaX for help if it can not return to normal.</li> </ul>
IE 100	PowerTypeFault	Power type fault <ul style="list-style-type: none"> <li>• Upgrade the software and press the <b>ESC</b> key to restart the inverter.</li> <li>• Or contact SolaX for help if it can not return to normal.</li> </ul>
IE 102	Mgr EEPROM Fault	Mgr E2prom Error. <ul style="list-style-type: none"> <li>• Shut down photovoltaic ,battery and grid, and then reconnect.</li> <li>• Or contact SolaX for help if it can not return to normal.</li> </ul>
IE 103	Fan4 Fault	FAN4 Fault <ul style="list-style-type: none"> <li>• Check if the foreign objects stuck in the fan.</li> <li>• Or contact SolaX for help.</li> </ul>

Error Code	Fault	Descriptions and Diagnosis
IE 104	NTC Sample Invalid	<p>NTC Sample Fault</p> <ul style="list-style-type: none"> <li>• Make sure the NTC is properly connected and the NTC is in good condition.</li> <li>• Please confirm that the installation environment is normal</li> <li>• Or contact SolaX for help if it can not return to normal.</li> </ul>
IE 107	CT Fault	<p>CT Fault</p> <ul style="list-style-type: none"> <li>• Check if the CT is working properly</li> <li>• Or contact SolaX for help if it can not return to normal.</li> </ul>
IE 109	Meter Fault	<p>Meter Fault</p> <ul style="list-style-type: none"> <li>• Check if the meter is working properly</li> <li>• Or contact SolaX for help if it can not return to normal.</li> </ul>
IE 110	BypassRelayFlt	<p>Bypass Relay Fault</p> <ul style="list-style-type: none"> <li>• Press the <b>ESC</b> key to restart the inverter.</li> <li>• Or contact SolaX for help if it can not return to normal.</li> </ul>
IE 111	FAN3 Fault	<p>FAN3 Fault</p> <ul style="list-style-type: none"> <li>• Check if the foreign objects stuck in the fan.</li> <li>• Or contact SolaX for help.</li> </ul>
IE 112	ARMParaComFlt	<p>ARM Parameter Communication fault</p> <ul style="list-style-type: none"> <li>• Check that the communication cables of inverters are well connected and the baud rate of COMM setting of inverters are the same.</li> <li>• Or contact SolaX for help if it can not return to normal.</li> </ul>
IE 113	FAN1 Fault	<p>FAN1 Fault</p> <ul style="list-style-type: none"> <li>• Check if the foreign objects stuck in the fan.</li> <li>• Or contact SolaX for help.</li> </ul>
IE 114	FAN2 Fault	<p>FAN2 Fault</p> <ul style="list-style-type: none"> <li>• Check if the foreign objects stuck in the fan.</li> <li>• Or contact SolaX for help.</li> </ul>
IE 115	20305Com Fault	<p>Com Fault</p> <ul style="list-style-type: none"> <li>• Check the connection of the monitoring module, reinsert the module.</li> <li>• Please contact SolaX for help.</li> </ul>
BE 01	BMS1_UCellOver BMS2_UCellOver	<p>Battery Error - Cell Overvoltage Fault</p> <ul style="list-style-type: none"> <li>• Please contact SolaX for help.</li> </ul>

Error Code	Fault	Descriptions and Diagnosis
BE 02	BMS1_UCellLow	Battery Error - Cell Undervoltage Fault • Please contact SolaX for help.
	BMS2_UCellLow	
BE 03	BMS1_UCellDiff	Battery Error - Large Cell Differential Pressure Fault • Please contact SolaX for help.
	BMS2_UCellDiff	
BE 04	BMS1_HVBOver	Battery Error - Total Voltage Overvoltage Fault • Please contact SolaX for help.
	BMS2_HVBOver	
BE 05	BMS1_HVBLow	Battery Error - Total Voltage Undervoltage Fault • Please contact SolaX for help.
	BMS2_HVBLow	
BE 06	BMS1_TempOver	Over temperature in battery system • Please contact SolaX for help.
	BMS2_TempOver	
BE 07	BMS1_SelfCheck	Self check fault in battery system • Please contact SolaX for help.
	BMS2_SelfCheck	
BE 08	BMS1_PoRlyAdh	Battery Error - Main Positive Relay Adhesion Fault • Please contact SolaX for help.
	BMS2_PoRlyAdh	
BE 09	BMS1_PoRlyOpen	Battery Error - Main Positive Open Relay Fault • Please contact SolaX for help.
	BMS2_PoRlyOpen	
BE 10	BMS1_NeRlyAdh	Battery Error - Main Negative Relay Adhesion Fault • Please contact SolaX for help.
	BMS2_NeRlyAdh	
BE 11	BMS1_NeRlyOpen	Battery Error - Main Negative Open Relay Fault • Please contact SolaX for help.
	BMS2_NeRlyOpen	
BE 12	BMS1_PreChgFail	Battery Error - Battery Precharge Fault • Please contact SolaX for help.
	BMS2_PreChgFail	
BE 13	BMS1_CellSample	Battery Error - Battery Cell Sampling Fault • Please contact SolaX for help.
	BMS2_CellSample	
BE 14	BMS1_TempSample	Battery Error - Battery Temperature Sampling Fault • Please contact SolaX for help.
	BMS2_TempSample	
BE 15	BMS1_Sys	Battery Error - Battery System Fault • Please contact SolaX for help.
	BMS2_Sys	

Error Code	Fault	Descriptions and Diagnosis
BE 16	BMS1_DsgOver	Battery Error - Battery Discharge Overcurrent Fault • Please contact SolaX for help.
	BMS2_DsgOver	
BE 17	BMS1_ChgOver	Battery Error - Battery Charge Overcurrent Fault • Please contact SolaX for help.
	BMS2_ChgOver	
BE 18	BMS1_AFESCom	Battery Error - Battery AFE communication Fault • Please contact SolaX for help.
	BMS2_AFESCom	
BE 19	BMS1_InvCom	Battery Error - Extranet Communication Fault • Please contact SolaX for help.
	BMS2_InvCom	
BE 20	BMS1_MidCom	Battery Error - Intermediate Network Communication Fault • Please contact SolaX for help.
	BMS2_MidCom	
BE 21	BMS1_VoltSensor	Battery Error - Voltage Sensor Fault • Please contact SolaX for help.
	BMS2_VoltSensor	
BE 22	BMS1_IDRepet	Battery Error - Repetitive ID Fault • Please contact SolaX for help.
	BMS2_IDRepet	
BE 23	BMS1_TempLow	Battery Error - Low Temperature Fault • Please contact SolaX for help.
	BMS2_TempLow	
BE 24	BMS1_CurrSensor	Battery Error - Current Sensor Fault • Please contact SolaX for help.
	BMS2_CurrSensor	
BE 25	BMS1_Line	Battery Error - Open Power Cable Fault • Please contact SolaX for help.
	BMS2_Line	
BE 26	BMS1_Flash	Battery Error - Flash Fault • Please contact SolaX for help.
	BMS2_Flash	
BE 27	BMS1_AFEProtect	Battery Error - AFE Self-protection Fault • Please contact SolaX for help.
	BMS2_AFEProtect	
BE 28	BMS1_ChgReq	Battery Error - Charge Request Fault • Please contact SolaX for help.
	BMS2_ChgReq	
BE 29	BMS1_Ins	Battery Error - Battery Insulation Fault • Check that the battery is properly grounded and restart the battery. • Please contact SolaX for help.
	BMS2_Ins	

Error Code	Fault	Descriptions and Diagnosis
BE 30	BMS1_MCB	Battery Error - Micro Circuit Breaker Fault • Please contact SolaX for help.
	BMS2_MCB	
BE 31	BMS1_LinkTemp	Battery Error - Contactor Over Temperature Fault • Please contact SolaX for help.
	BMS2_LinkTemp	
BE 32	BMS1_BatLinker	Battery Error - Internal contact point Abnormally high in the battery • Please contact SolaX for help.
	BMS2_BatLinker	
BE 33	BMS1_Fan	Battery Error - Fan Fault • Check if the foreign objects stuck in the fan. • Or contact SolaX for help.
	BMS2_Fan	

## 11.4 Maintenance

Regular maintenance is required for the device. The table below lists the operational maintenance for expressing the optimum device performance. More frequent maintenance service is needed in the worse work environment. Please make records of the maintenance.



**WARNING!**

- Only qualified person can perform the maintenance for the device.
- Only use the spare parts and accessories approved by SolaX for maintenance.

### Maintenance routine of battery cabinet

Table 11-2 Power on routine maintenance list

Check Item	Description	Interval Time
The operating status and environment of the system	<ul style="list-style-type: none"> <li>• Check whether there is any damage to the distributed energy system, and the device is deformed.</li> <li>• Check whether there is any abnormal noise in the running system.</li> <li>• Check whether the temperature of the device shell is normal. Meanwhile, it is suggested to use a thermal imager or any other monitoring systems to identify signs of heat.</li> <li>• Check whether the surrounding is at normal humidity level, and there is any damage to the dust and air filters.                             <ol style="list-style-type: none"> <li>a. Must ensure that the air intake is well ventilated. Otherwise, the battery pack failure will be caused due to overheating.</li> <li>b. Please gently open the door to prevent raising dust from the filter cotton. Otherwise, the smoke detector will alarm and give a command to the automatic fire sprinkler to spray gas.</li> </ol> </li> </ul>	Every 6 months
Cabinet screen	<ul style="list-style-type: none"> <li>• Check whether the screen displays normally.</li> <li>• Check <b>Alarm info</b> on the screen.</li> </ul>	Every 6 months
Battery pack	<ul style="list-style-type: none"> <li>• Check whether the fan of the battery pack is running normally</li> <li>• Check the appearance of the battery pack for damage or deformation.</li> <li>• Check whether there is any abnormal noise during operation.</li> </ul>	Every 6 months

Check Item	Description	Interval Time
Inverter	<ul style="list-style-type: none"> <li>• Check whether the fan of the inverter is running normally</li> <li>• Check the appearance of the inverter for damage or deformation.</li> <li>• Check whether there is any abnormal noise during operation.</li> </ul>	Every 6 months
Air conditioner and cabinet fan	<ul style="list-style-type: none"> <li>• Check that there are no potential hazards and contaminants around the device, and that there is no rubbish in the vicinity.</li> <li>• Check whether there is any abnormal noise, abnormal vibration and blade jamming in the running outdoor unit fan.</li> </ul>	Every 6 months
Smoke detector, temperature sensor, toxic gases detector	<ul style="list-style-type: none"> <li>• Check the appearance and patrol lights visually.</li> <li>• Use special testing device to add smoke or heat on smoke detectors and temperature detectors to test the action of the detectors.</li> </ul>	Every 6 months
Aerosol	<ul style="list-style-type: none"> <li>• Check the appearance of the aerosol: no deformation and nozzle integrity, confirm no agent leakage</li> </ul>	Every 6 months
Distribution box, UPS	<ul style="list-style-type: none"> <li>• Check the appearance for damage or deformation.</li> <li>• Check whether there is any abnormal noise during operation.</li> </ul>	Every 6 months
EMS, I/O module	<ul style="list-style-type: none"> <li>• Check whether the indicator lights normally.</li> </ul>	Every 6 months
Antennae	<ul style="list-style-type: none"> <li>• Check whether the antenna is rusty due to salt spray, if so, the antenna needs to be replaced.</li> </ul>	Every 6 months
Safety function	<ul style="list-style-type: none"> <li>• Check whether the emergency stop button and LED is in good working condition.</li> <li>• Check the stopping signal and communication by simulating the shutdown operation.</li> <li>• Check whether there are any damages to warning signs and other labels pasted on the device. If so, please replace them in time.</li> </ul>	Every 6 months

**NOTICE!**

The system must be shut down before perform the following maintenance.

Table 11-3 Power off routine maintenance list

Check Item	Description	Interval Time
Electrical connection	<ul style="list-style-type: none"> <li>• Check whether the power cables are fastened securely. If not, please tighten them again according to the torque written in the document.</li> <li>• Check the electrical connection of battery packs, inverter, distribution box, UPS and other major devices for looseness and cable jacket damage, especially the cable jacket connecting with the metal parts.</li> <li>• Check whether the inverter, distribution box and UPS are reliably grounded.</li> <li>• Verify that the sealing caps on idle terminals of inverter are and not falling off.</li> <li>• Check whether the electrical insulation tape is in good condition and no peeling.</li> </ul>	The check shall be scheduled within one month after the first commissioning, and then can be scheduled every 6 months
Terminal and block connection	<ul style="list-style-type: none"> <li>• Check whether there is any fading to the screws and copper bars.</li> <li>• Check whether the screws are fastened securely. If not, please tighten them again according to the torque written in the document.</li> </ul>	The check shall be scheduled within one month after the first commissioning, and then can be scheduled every 6 months
System cleaning	<ul style="list-style-type: none"> <li>• Check whether the circuit boards and components are clean.</li> <li>• Check whether the heat sink of the inverter is covered with foreign objects.</li> <li>• Check and clean the filter to ensure that there is no dirty blockage of air conditioner and cabinet fan.</li> <li>• Clean the inverter cooling fans with a soft dry cloth or brush or replace it if necessary.</li> <li>• If necessary, clean the modules by air compressor.</li> </ul> <p><b>The maintenance period shall be shortened if the cabinet is installed in heavily polluted environments.</b></p>	Every 6 months

### 11.4.1 Disassembly and Clean of Air Conditioner Filter



- The air conditioner must be powered off before disassembly and clean of air conditioner.
- The device may still have power and heat after turning off, which may cause electric shock and personal injuries. Therefore, please allow it to cool for at least 5 minutes and wear PPE before conducting maintenance.

**Step 1:** Unscrew M6 screws, and orderly dismantle aluminum mesh plate, stainless steel gauze, and black filter.

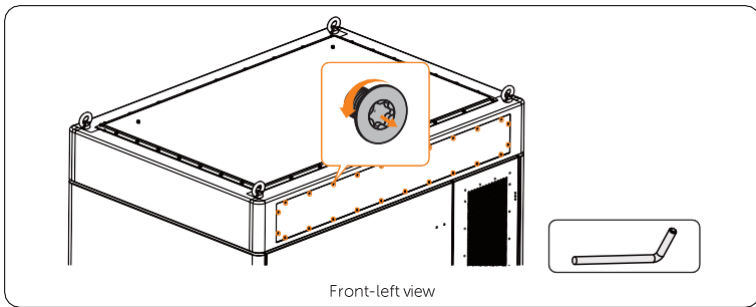

Figure 11-9 Unscrewing M5 screws

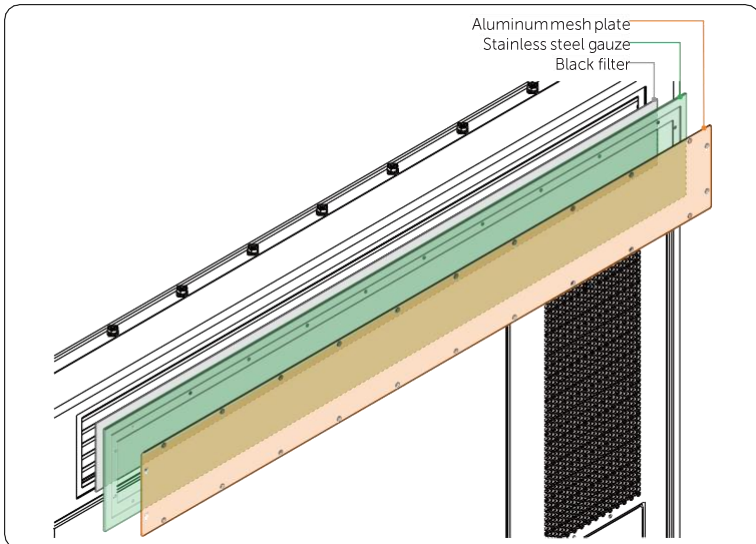

Figure 11-10 Dismantling aluminum mesh plate, stainless steel gauze, black filter

- Step 2:** Clean aluminum mesh plate and stainless steel gauze, and replace the black filter.
- Step 3:** Orderly reinstall the black filter, stainless steel gauze, and aluminum mesh plate.
- Step 4:** Insert and tighten M6 screws (x 24).

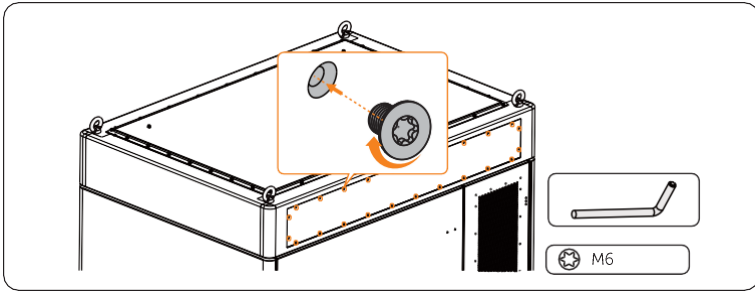

Figure 11-11 Tightening M6 screws

# 12 Decommissioning

---

## 12.1 Disposing of the Wasted and Damaged Battery Pack

Regarding the wasted or damaged battery packs, SolaX will not recycle them. Therefore, users can contact a recycling agency to dispose of them. The expenses incurred shall be borne by the users themselves.

**Step 1:** Contact a recycling agency, and estimate the expenses.

**Step 2:** The recycling agency will take full responsibility for dispose of the wasted or damaged battery packs.

## 12.2 Disposing of the Wasted and Damaged Inverter

Please dispose of the inverters or accessories in accordance with the disposal regulations for electronic waste which is applied at the installation site.

# 13 Technical Data

## DC side

Model	AELIO-P50B200	AELIO-P60B200
Max. PV input power [kW]	100	120
Max. PV input voltage [V]	1000	1000
Start output voltage [V]	180	180
Rated input voltage [V]	650	650
MPPT voltage range [V]	160~950	160~950
No. of MPP trackers / Strings per MPP tracker	5 (2 per MPPT)	6 (2 per MPPT)
Max. input current [A]	40	40
Max. input short circuit current [A]	50	50

## AC side

Model	AELIO-P50B200	AELIO-P60B200
Rated AC output power [kW]	50.0	60.0
Rated AC output current [A]	75.8 @ 220V 72.5 @ 230V 69.5 @ 240V	91.0 @ 220V 87.0 @ 230V 83.4 @ 240V
Max. AC output apparent power [kVA]	55.0	66.0
Max. AC output current [A]	83.4 @ 220V 79.8 @ 230V 76.4 @ 240V	100.0 @ 220V 95.7 @ 230V 91.7 @ 240V
Nominal grid voltage [V]	3/N/PE, 220/380, 230/400, 240/415	
Nominal grid frequency [Hz]	50/60	
Auxiliary Power Input Voltage [a.c. V]	L/N/PE, 220, 230, 240	
Auxiliary Power Input Current [a.c. A]	Max. 10	
Auxiliary Power Frequency [Hz]	50/60	
Auxiliary Power Short Current [A]	350	
Adjustable power factor range	1 (0.8 Leading ~ 0.8 Lagging)	
THDi (Rated power) [%]	< 3	

## Battery

Model	AELIO-P50B200	AELIO-P60B200
Battery type	LiFePO4	
Rated battery capacity [kWh]	200	
Rated battery voltage [V]	716.8	
Battery voltage range [V]	560~817.6	
Discharge depth [%]	90	
Rated charge/discharge current [A]	140	
Max charge/discharge current [A]	160 (80 × 2)	

## General parameter

Model	AELIO-P50B200	AELIO-P60B200
Dimensions (with Inverter) (W×H×D) [mm]	2070 × 2420 × 1200	
Dimensions (without Inverter) (W×H×D) [mm]	1680 × 2420 × 1200	
Weight (with Inverter) [kg]	2800	
Weight (without Inverter) [kg]	2700	
Operating ambient temperature range [°C]	-30~50	
Relative humidity(Non-condensing) [%]	0~100	
Max. operating altitude [m]	3000	
Cooling concept	Smart air cooling	
Ingress protection	Cabinet: IP55; Inverter: IP66	
Fire protection	Aerosol / Water	
Topology	Non-isolated	
Standard	IEC62619, IEC63056:2000, IEC61000, IEC62477-1, UN38.3	

# 14 Appendix

## 14.1 Requirements for OT/DT/TO Terminal

For different types of cables, select proper terminals and additional components for connection.

### CAUTION!

- Do not connect the aluminum wiring terminal directly to the terminal block or copper bar in case of electrochemical corrosion, which might affect the reliability of cable connection.
- While using an aluminum wiring terminal, copper washer, and aluminum washer, pay special attention to the position of the two washers. The copper washer shall make contact with the terminal block, and the aluminum washer shall make contact with the aluminum wiring terminal.

### NOTICE!

- The copper-to-aluminum wiring terminal used in scenario 3, and aluminum wiring terminal, copper washer, and aluminum washer used in scenario 4 must comply with the requirements in IEC61238-1.

Table 14-1 Terminal requirements for different types of cables

Scenario	Cable Type	Wiring Terminal Type	Figure Illustration
1	Copper cable	Copper wiring terminal	
2	Copper-clad aluminum cable	Copper wiring terminal	

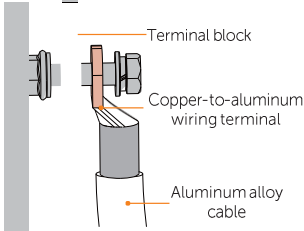
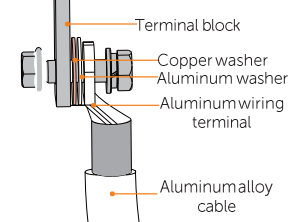
Scenario	Cable Type	Wiring Terminal Type	Figure Illustration
3	Aluminum alloy cable	Copper-to-aluminum wiring terminal	 <p>Terminal block</p> <p>Copper-to-aluminum wiring terminal</p> <p>Aluminum alloy cable</p>
4	Aluminum alloy cable	<ul style="list-style-type: none"> <li>• Aluminum wiring terminal</li> <li>• Copper washer</li> <li>• Aluminum washer</li> </ul>	 <p>Terminal block</p> <p>Copper washer</p> <p>Aluminum washer</p> <p>Aluminum wiring terminal</p> <p>Aluminum alloy cable</p>

## 14.2 How to Repaint the Cabinet

Check the paint damage on the surface of the cabinet, with details below:

- For light scratches or small areas of stubborn stains, please see “14.2.1 Light Scratches & Small Areas of Stubborn Stains” to treat them.
- If the deep scratches or large areas of stubborn stains can be treated by users, please refer to “14.2.2 Deep Scratches and Large Areas of Stubborn Stains”.
- If the damaged area is too large and cannot be treated, please contact the after-sale personnel for assistance.

### WARNING!

- If the cabinet is installed outdoors without shield, do not repaint it in rainy, snowy, windy, or stormy days.

### NOTICE!

- Use paint of pantone11-4202TPG color.
- For light scratches and small areas of stubborn stains, spray paint and hairbrush are recommended.
- For deep scratches or large areas of stubborn stains, oil paint and paint sprayer are recommended.

### 14.2.1 Light Scratches & Small Areas of Stubborn Stains

This solution applies to light scratches without reaching the steel substrate and stubborn stains on the surface.

#### Tools and materials required

Prepare tools and enough materials according to actual conditions.

Table 14-2 Tools and materials

No.	Tool/Material	No.	Tool/Material
1	Spray/oil paint	2	Fine sandpaper
3	Anhydrous ethanol	4	Cotton cloth
5	Hairbrush (for small scratched area)	6	Spray paint (if there is a large area of light scratch, paint sprayer is recommended.)

### Repainting procedure

**Step 1:** Gently sand the scratched area with a fine sandpaper to remove rust and stains on the surface.

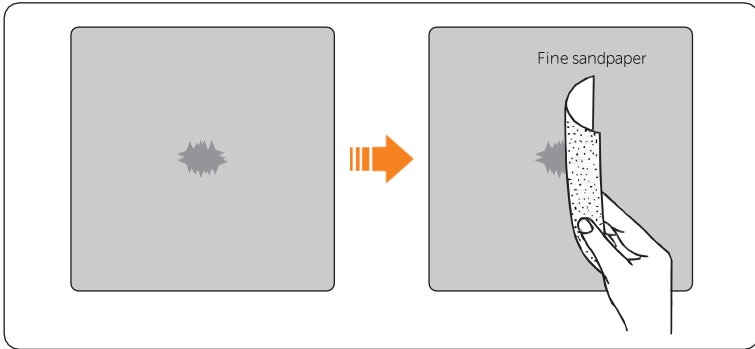

Figure 14-1 Sanding the scratched area

**Step 2:** Moisten a cotton cloth with anhydrous ethanol, wipe the scratched area with it to remove dust and dirt, and then use a dry cotton cloth to wipe the area dry.

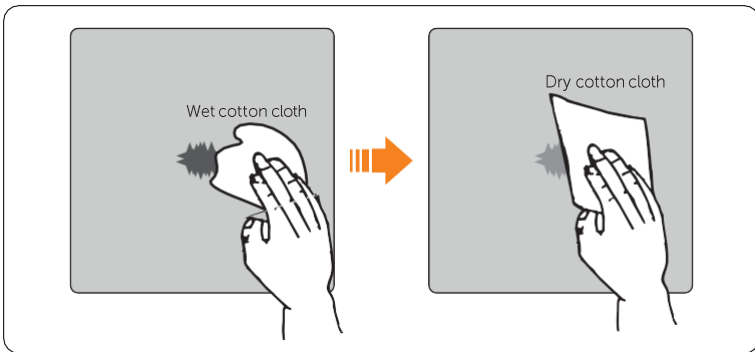

Figure 14-2 Cleaning the scratched area

**Step 3:** Use hairbrush or spray paint to apply paint to the surface of the scratched area until it is fully and evenly covered.

#### NOTICE!

- While applying paint, make sure the newly applied paint is thin and even, so that the scratched area can appear consistent and smooth on the surface.
- If there is color difference between the scratched area and the surroundings, cover the surrounding area with tape or paper in case of color contamination.

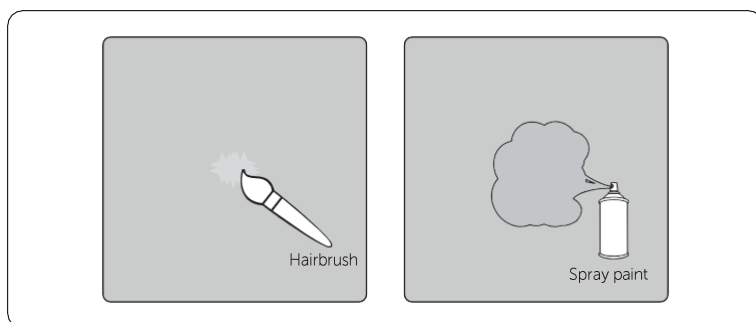

Figure 14-3 Applying paint

**Step 4:** After completing applying the paint, wait for around 30 minutes for the paint to get dry, and then check whether the repaired area meets the requirements.

#### NOTICE!

- The color of the repaired area shall be consistent with the surrounding area.
  - » Use a colorimeter to measure the color difference, of which Delta E shall be  $\leq 3$ .
  - » If the color cannot be measured by a colorimeter, make sure that there is no obvious color difference at the edges between the repaired area and the surrounding area, as well as no bumps, scratches, flakings, or breaks.
- For spray painting, we recommend painting for at least 3 times before pausing to check the effect, and then repeat spray painting and observing until it meets the requirements.

### 14.2.2 Deep Scratches and Large Areas of Stubborn Stains

This solution applies to deep scratches where the primer has been damaged and reach the steel substrate.

#### Tools and materials required

Prepare tools and enough materials according to actual conditions.

Table 14-3 Tools and materials

No.	Tool/Material	No.	Tool/Material
1	Spray/oil paint	2	Zinc-rich primer
3	Fine sandpaper	4	Anhydrous ethanol
5	Cotton cloth	6	Hairbrush (for small areas of deep scratches and stubborn stains)

---

No.	Tool/Material	No.	Tool/Material
7	Paint sprayer (for large areas of deep scratches and stubborn stains)		

---

### Repainting procedure

**Step 1:** Gently sand the scratched area with a fine sandpaper to remove rust and stains on the surface.

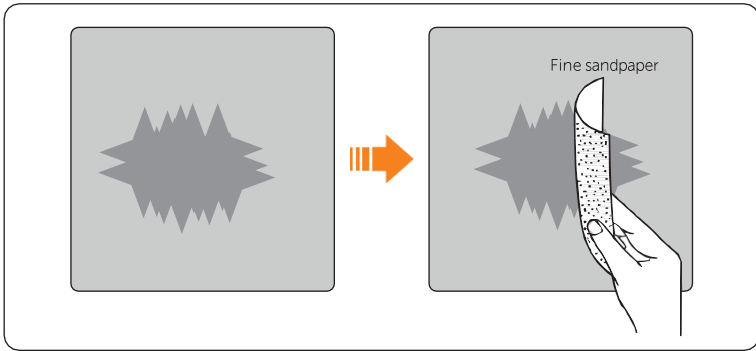

Figure 14-4 Sanding the scratched area

**Step 2:** Moisten a cotton cloth with anhydrous ethanol, wipe the scratched area with it to remove dust and dirt, and then use a dry cotton cloth to wipe the area dry.

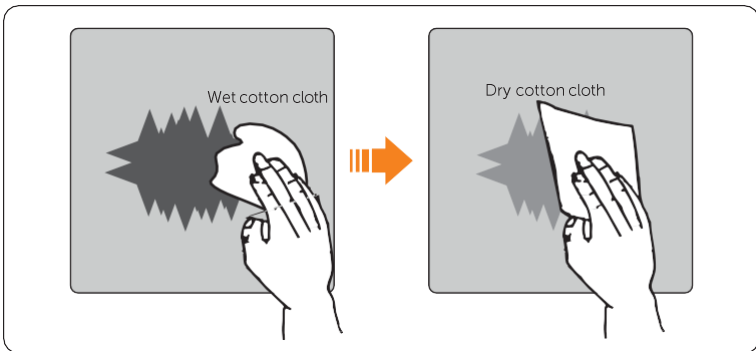

Figure 14-5 Cleaning the scratched area

**Step 3:** Use a paint spray to apply the zinc-rich primer to the scratched area.

**NOTICE!**

- If the steel substrate is visible on the scratched area, the zinc-rich primer must be applied first to entirely cover the substrate.
- Wait for the primer to get dry before applying the top coat to the scratched area.

**Step 4:** Use a paint spray to apply paint to the surface of the scratched area until it is fully and evenly covered.

**NOTICE!**

- While applying paint, make sure the newly applied paint is thin and even, so that the scratched can appear consistent and smooth on the surface.
- If there is color different between the scratched area and the surroundings, cover the surrounding area with tape or paper in case of color contamination.

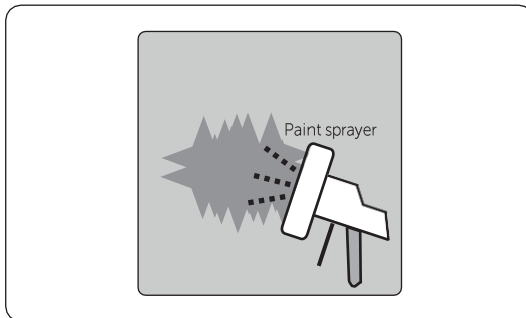

Figure 14-6 Applying paint

**Step 5:** After completing applying the paint, wait for around 30 minutes for the paint to get dry, and then check whether the repaired area meets the requirements.

**NOTICE!**

- The color of the repaired area shall be consistent with the surrounding area.
  - » Use a colorimeter to measure the color difference, of which Delta E shall be  $\leq 3$ .
  - » If the color cannot be measured by a colorimeter, make sure that there is no obvious color difference at the edges between the repaired area and the surrounding area, as well as no bumps, scratches, flakings, or breaks.
- For spray painting, we recommend painting for at least 3 times before pausing to check the effect, and then repeat spray painting and observing until it meets the requirements.

### 14.2.3 Logo & Pattern damaged, Dents or Dings

In this case, we recommend contacting a local spray painting company for customized treatment based on the actual conditions.

Table 14-4 Damage extent and recommended solution

No.	Damaged Area	Recommended Solution
1	<ul style="list-style-type: none"><li>• Size &lt; 100 mm<sup>2</sup></li><li>• depth &lt; 3 mm</li></ul>	Use a poly-putty base to fix the dents and dings first, and then deal with them according to " <a href="#">Repainting procedure</a> " for Deep Scratches.
2	<ul style="list-style-type: none"><li>• Size &gt; 100 mm<sup>2</sup></li><li>• depth &gt; 3 mm</li></ul>	Contact local supplier to make a plan for repair.

## 14.3 Micro-grid Application

### 14.3.1 Introduction of Micro-grid Application

Due to Islanding Effect, on-grid inverter is unable to work during off-grid. This characteristic makes user losing the on-grid inverter PV energy when off-grid. Micro-grid is the function that making hybrid inverter simulate the grid to active on-grid inverter during off-grid by connecting on-grid inverter to hybrid inverter's EPS terminal.

### 14.3.2 Wiring Connection Diagram

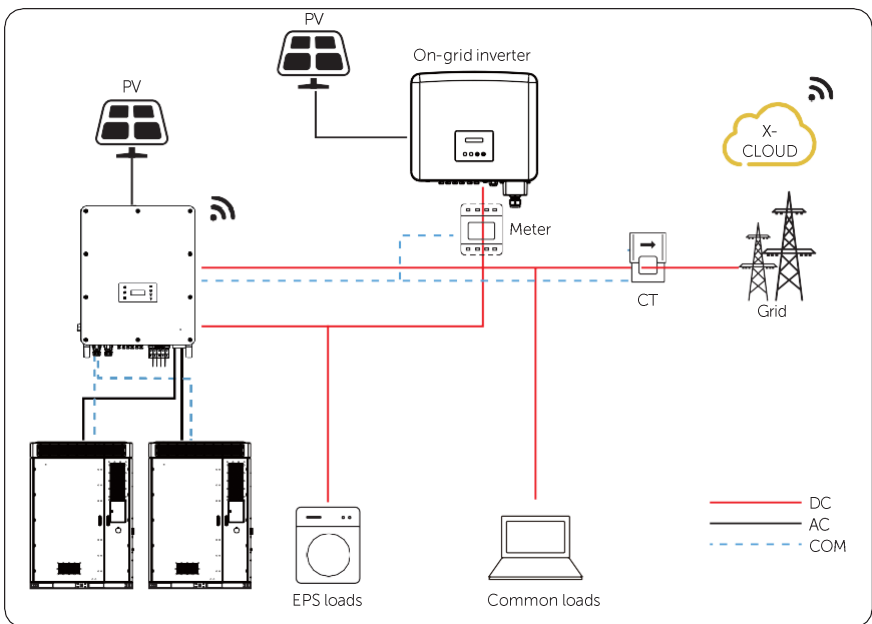

Figure 14-1 Micro-grid wiring connection

### 14.3.3 Working Modes

#### Grid on

- When PV is sufficient, the hybrid and on-grid inverters power the general and critical loads together. When there is surplus energy on the on-grid inverter, it will also charge the battery connected to the hybrid inverter.
- When PV is insufficient, the hybrid, on-grid inverter and grid power all the loads.

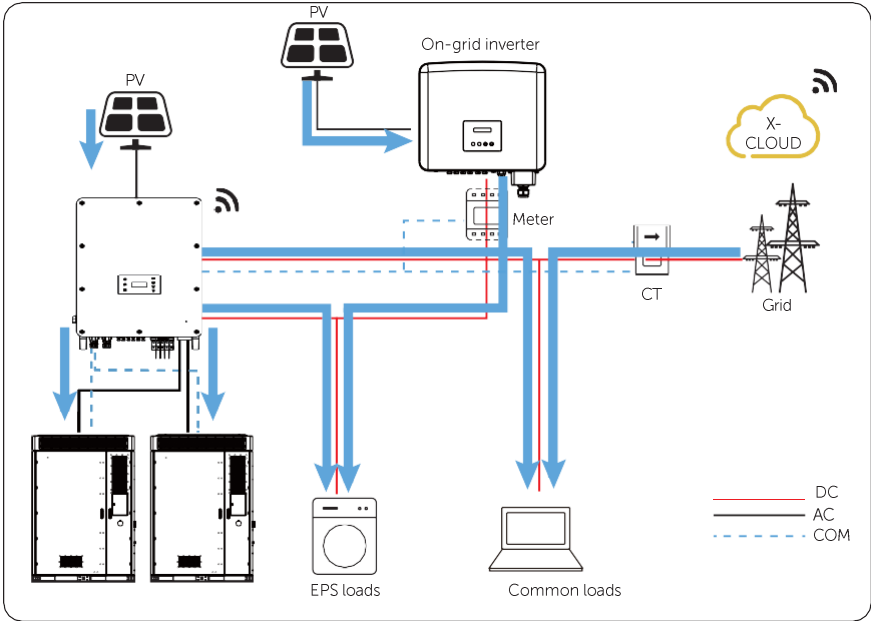

Figure 14-2 Power flowing when grid on and PV sufficient

## Grid off

In this case, the hybrid inverter will simulate the grid so as to make the on-grid inverter can still work. Hybrid and on-grid inverter will power the EPS loads together. If there is surplus energy, it will charge the battery.

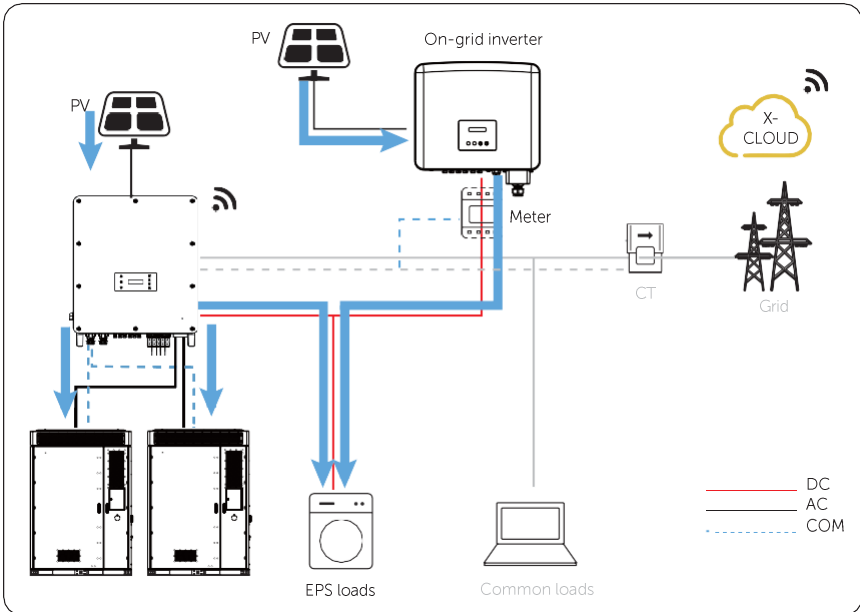

Figure 14-3 Power flowing when grid off

## Notice for Micro-grid application

- Any brand of on-grid inverter that supports "frequency adaptation"
- On-grid inverter output power  $\leq$  Max hybrid inverter EPS output power
- On-grid inverter output power  $\leq$  Max battery charging power, refer to the table below:

### NOTICE!

- Since X3-AELIO series inverter is unable to control the output power of on-grid inverter in grid connection mode, therefore X3-AELIO series inverter can not achieve zero export when loads power + battery charging power < on-grid inverter output power.

### 14.3.4 Cable Connection (Hybrid inverter)

Please refer to "7.2.3 AC Connection" for Grid and EPS connection on X3-AELIO series inverter.

### 14.3.5 Cable Connection (On-grid Inverter)

Please connect the AC cable of on-grid inverter to the EPS terminal of X3-AELIO series inverter through a circuit breaker. Please refer to the user manual of specific on-grid inverter.

### 14.3.6 Cable Connection (Meter)

To detect and monitor the power data generated from the on-grid inverter, you can install a meter on the on-grid inverter side. Otherwise, the relevant power data of on-grid inverter can not be monitored.

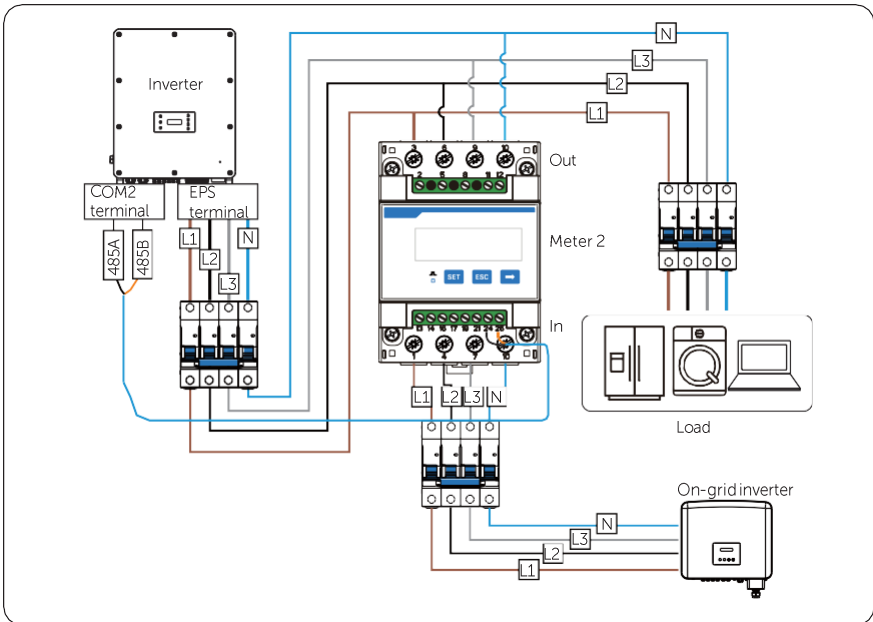

Figure 14-4 Connection diagram of Meter on EPS terminal

## NOTICE!

- If one-to-two adapter for RJ45 terminal is used, it should be placed in a waterproof enclosure.

- Pin definition

Table 14-1 Pin definition for meter and CT

Application	For CT1			For meter		For CT2		
Pin	1	2	3	4	5	6	7	8
Assignment	CT_ R1_ CON	CT_ S1_ CON	CT_ T1_ CON	METER _485A	METER _485B	CT_ T2_ CON	CT_ S2_ CON	CT_ R2_ CON

- Meter/CT connection steps

Please refer to “14.4 CT/Meter Connection Scenarios” and meter/CT user manual for specific connection steps.

- Setting on the LCD

Setting path: **Menu>Setting>Advance Setting>Meter/CT Setting**

① For meter 1 and meter 2 solution (Meter 1 for grid connection, Meter 2 for EPS connection)

- Select and enter the **Meter/CT Setting** according the setting path.
- Set the address and direction of Meter 1: You can check the connection status in **Meter/CT Check**.



- Set the address and direction of Meter 2: You can check the connection status in **Meter/CT Check**.



- After connection succeeded, check the feed-in power of Meter 1 in the path of **Menu>System Status>Meter/CT** and check the output power (**Output Today** and **Output Total**) of Meter 2 in the path of **Menu>History Data>E\_USERDEF**.

② For CT and meter 2 solution (CT for grid connection, Meter 2 for EPS connection)

- a. Select and enter the **Meter/CT Setting** according the setting path.
- b. The default device is CT and the status is enable by default. You can check the connection status in **Meter/CT Check**.
- c. Set the address and direction of Meter 2: You can check the connection status in **Meter/CT Check**.



- d. After connection succeeded, check the feed-in power of Meter 1 in the path of **Menu>System Status>Meter/CT** and check the output power (**Output Today** and **Output Total**) of Meter 2 in the path of **Menu>History Data>E\_USERDEF**.

## 14.4 CT/Meter Connection Scenarios

X3-AELIO inverter series can be connected to a single batch of CTs, a direct-connected meter, or a CT-connected meter, and also supports a Meter 2 function for you to monitor another power generation device at home.

Followings are the detailed wiring and setting procedures of these scenarios. For wiring procedure of the inverter CT/Meter port, see "[CT/Meter connection](#)".

### 14.4.1 Connection of CT

#### NOTICE!

- Do not place the CT on the N wire or ground wire.
- Do not put CT on the N line and L line at the same time.
- Do not place the CT on the side where the arrow points to the inverter.
- Do not place the CT on non-insulated wires.
- The cable length between CT and inverter should not exceed 10 meters.
- It is recommended to wrap the CT clip around in circles with insulating tape.

#### NOTICE!

- The CTs referred to in this section are the CT batch delivered with the inverter.

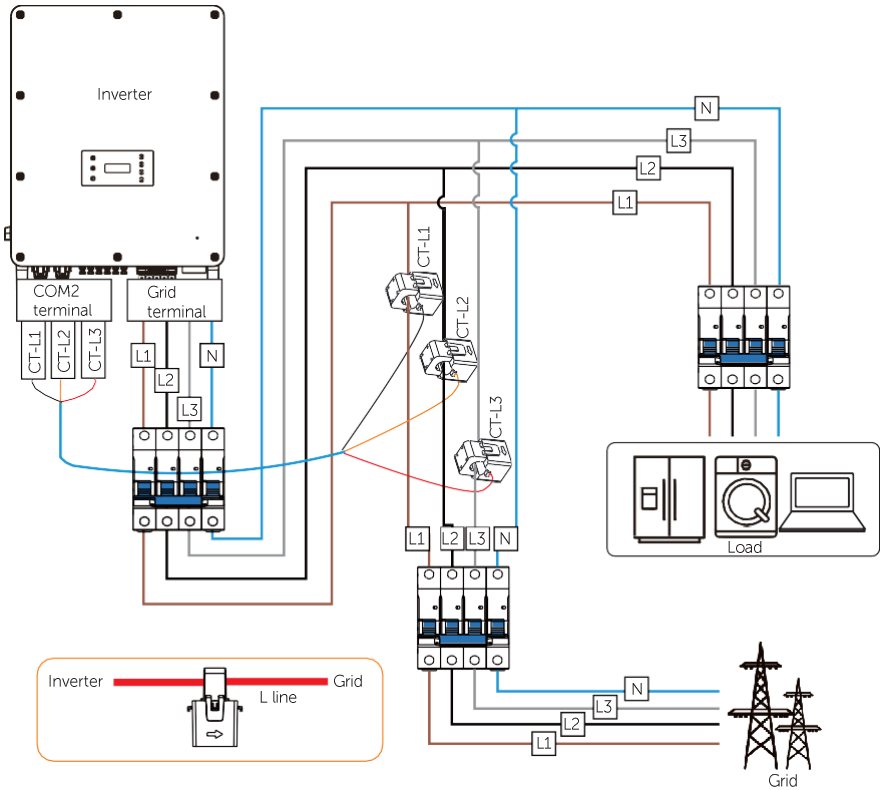

Figure 14-5 System wiring with CT

**NOTICE!**

- The arrow on the CT must point at the public grid.
- Markings on the CTs might be R, S and T or L1, L2 and L3. Make sure to clip CT-R/CT-L1 to the L1 wire, CT-S/CT-L2 to the L2 wire, and CT-T/CT-L3 to the L3 wire.
- The emergency load is connected to the EPS terminal of the inverter, which is not shown in the diagram.

## Wiring procedure

**Step 1:** Clip CT\_L1, CT\_L2 and CT\_L3 respectively onto the L1, L2 and L3 cables of the grid.

Make sure the arrow on the CTs is pointing to the grid side from the inverter.

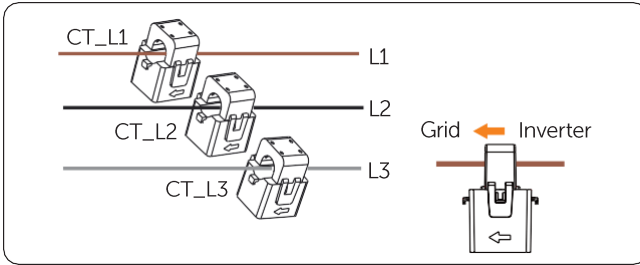

Figure 14-6 Clipping CTs to grid cables

**Step 2:** Use the RJ45 coupler to connect the extension communication cable and the batch of CTs.

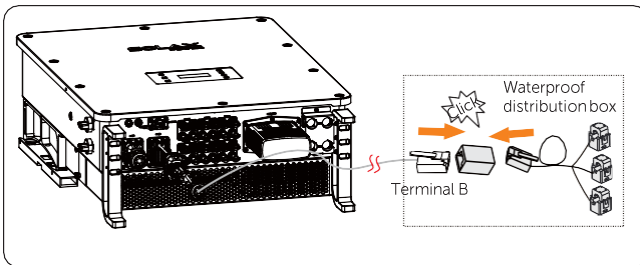

Figure 14-7 Connecting to CT

## Setting procedure

After connecting CT to the inverter, set parameters for them on the inverter.

**Step 1:** Select **Advance Settings > Meter/CT Setting**.

**Step 2:** Enable CT, and then select the supported CT type.

You can check the connection status in **Meter/CT Check**. For details, see "[Setting Meter/CT Check](#)".

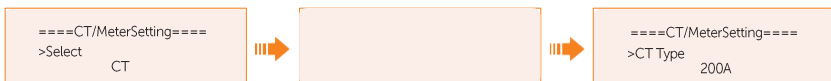

Figure 14-8 Setting CT for the inverter

### 14.4.2 Connection of Direct-connected Meter

**NOTICE!**

- The following figures take inverter with Meter DTSU666 as an example.
- Please make PE connection for Meter if the meter has ground terminal.

- Meter connection diagram

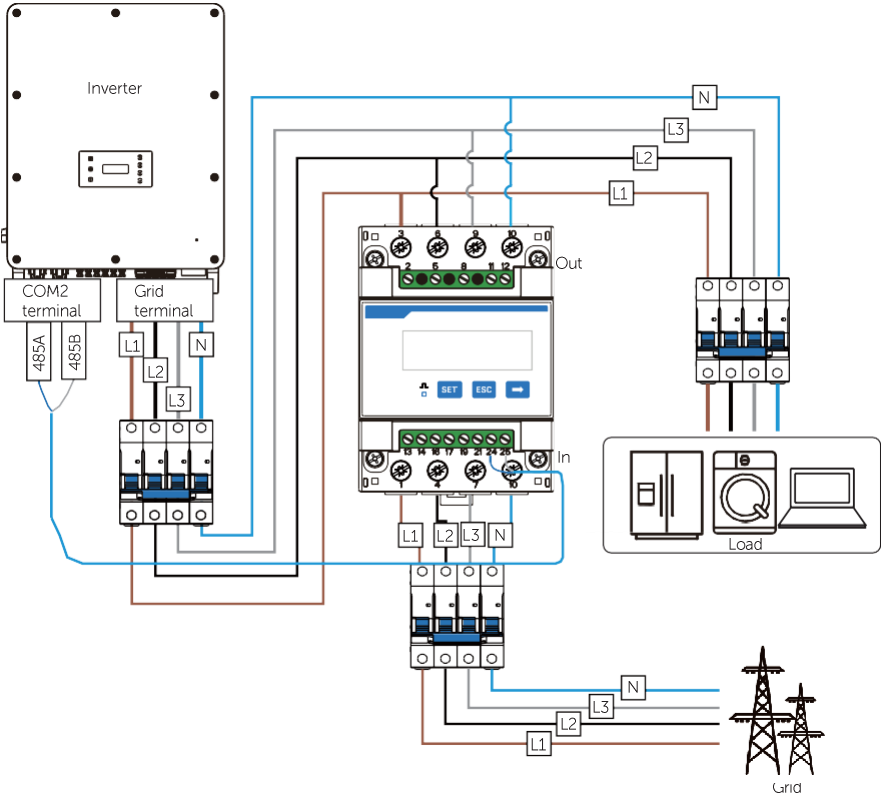

Figure 14-9 System wiring with direct-connected meter

**NOTICE!**

- For direct-connected meter, the current flow direction should be from grid to the inverter.
- Terminal 1, 4 and 7 of the meter must be connected to the grid side, and terminal 3, 6 and 9 be connected to the inverter side of the system. Otherwise, the system power data might be misread.

## Meter terminal definition

Table 14-2 Terminal definition of SolaX direct-connected meter

Terminal No.	Definition	Description
1, 4, 7	UA*, UB*, UC*	Voltage input terminal of phase A, B and C, respectively connected to L1, L2 and L3 wire
3, 6, 9	UA, UB, UC	Voltage output terminal of the three phases, respectively connected to L1, L2 and L3 wire
10	UN	Connected to the N wire
24	RS485A	RS485 terminal A
25	RS485B	RS485 terminal B

## Wiring procedure

**Step 1:** Strip around 10 mm wire insulation off the grid voltage cables, and then connect L1, L2 and L3 wires respectively to terminal 1 and 3, 4 and 6, 7 and 9, and N wire to terminal 10 of the meter.

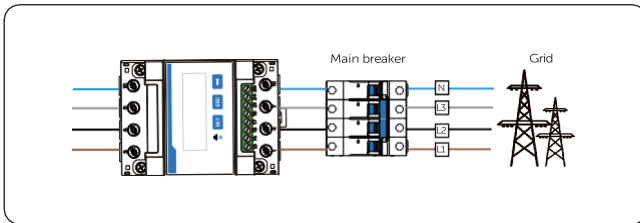

Figure 14-10 Connecting direct-connected meter to the grid

**Step 2:** Strip 15 mm wire insulation off the other end of the communication cable.

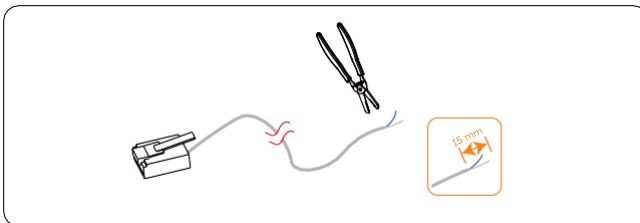

Figure 14-11 Stripping communication cable for meter

**Step 3:** Connect the conductors to terminal 24 and 25 of the meter.

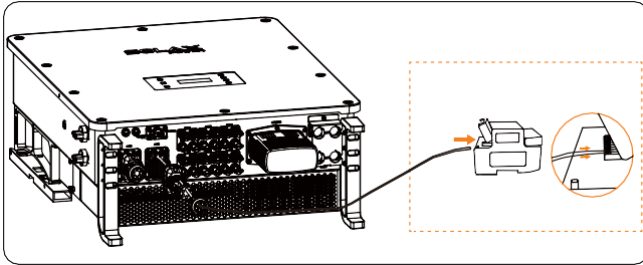

Figure 14-12 Connecting inverter to meter

### Setting procedure

After connecting meter to the inverter, set parameters of the meter on the inverter.

**Step 1:** Select **Advance Settings > Meter/CT Setting**.

**Step 2:** Enable **Meter**, and then set **Meter1Addr** to **1** and **Meter1 Direction** to **Positive**.

You can check the connection status in **Meter/CT Check**. For details, see "[Setting Meter/CT Check](#)".



Figure 14-13 Setting meter for the inverter

### 14.4.3 Connection of CT-connected Meter

#### NOTICE!

- The following figures take inverter with Meter DTSU666-CT as an example.
- Please make PE connection for Meter if the meter has ground terminal.
- The CTs referred to in this section are CTs that are delivered with the CT-connected meter.

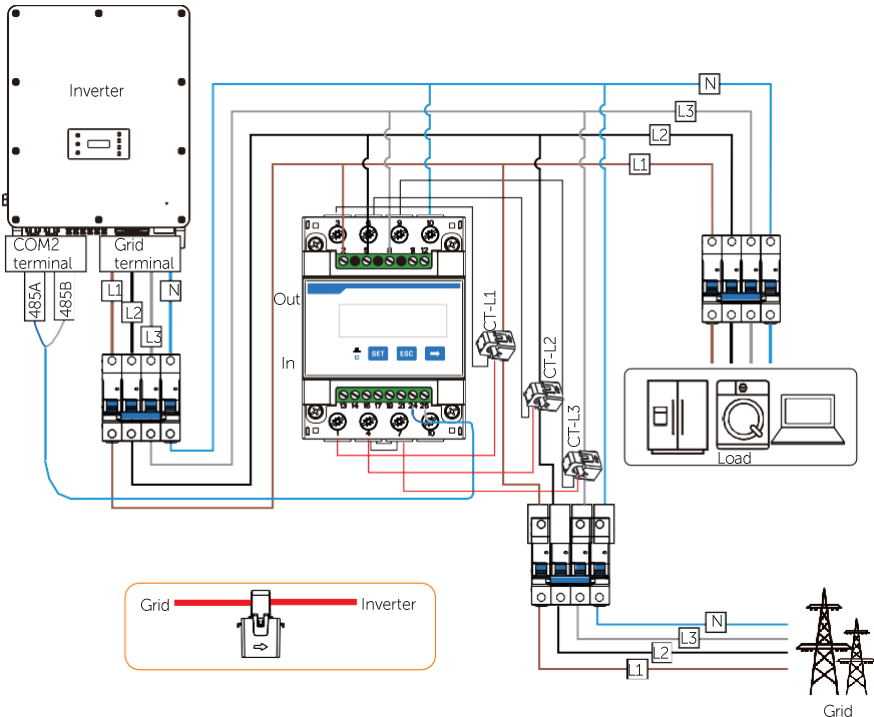

Figure 14-14 System wiring with CT-connected meter

#### NOTICE!

- Terminal 2, 5 and 8 of the meter must be connected to the grid side. Terminal 1, 4 and 7 must be connected to the S1 wire of the CTs. Otherwise, the system power data might be misread.
- The arrow on the CT must point at the inverter.
- Markings on the CTs might be R, S and T or L1, L2 and L3. Make sure to clip CT-R/CT-L1 to the L1 wire, CT-S/CT-L2 to the L2 wire, and CT-T/CT-L3 to the L3 wire.

**Meter terminal definition**

Table 14-3 Terminal definition of SolaX CT-connected meter

Terminal No.	Definition	Description
2, 5, 8	UA, UB, UC	Voltage input terminal of phase A, B and C respectively connected to L1 L2 and L3 wire
10	UN	Connected to the N wire
1, 4, 7	IA*, IB*, IC*	Current input terminal of the three phases, connected to the S1 wire of CT
3, 6, 9	IA, IB, IC	Current input terminal of the three phases, connected to the S2 wire of CT
24	RS485A	RS485 terminal A
25	RS485B	RS485 terminal B

**Wiring procedure**

- Step 1:** Strip around 10 mm wire insulation off the voltage cables, and then connect L1, L2 and L3 wires respectively to terminal 2, 5 and 8, and the N wire to terminal 10 of the meter.
- Step 2:** Clip the CTs onto the L1, L2 and L3 wires in the direction from grid to inverter.
- Step 3:** Connect the S1 wire of the three included CTs respectively to terminal 1, terminal 4 and terminal 7, and S2 wire of the CTs respectively to terminal 3, 6 and 9 of the meter.

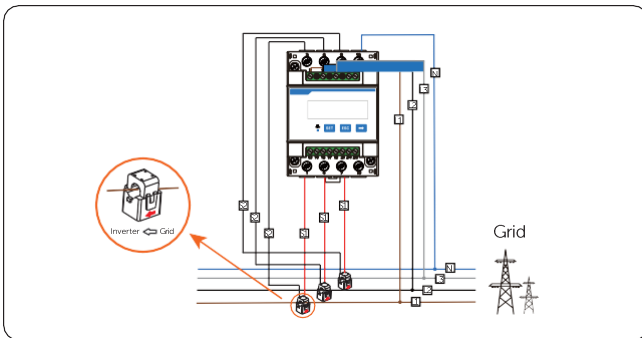

Figure 14-15 Connecting CT-connected meter to the grid

**Step 4:** Strip 15 mm wire insulation off the other end of the communication cable.

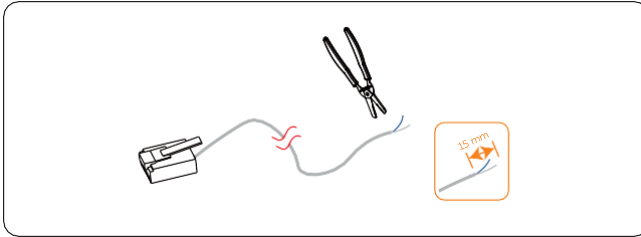

Figure 14-16 Stripping communication cable for meter

**Step 5:** Connect the conductors to terminal 24 and 25 of the meter.

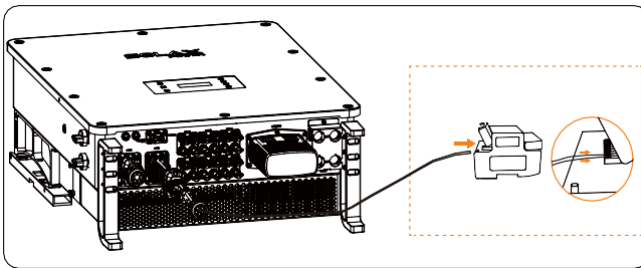

Figure 14-17 Connecting inverter to meter

### Setting procedure

After connecting CT to the inverter, set parameters for them on the inverter.

**Step 1:** Select **Advance Settings > Meter/CT Setting**.

**Step 2:** Enable **Meter**, and then set **Meter1Addr** to **1** and **Meter1 Direction** to **Positive**.

You can check the connection status in **Meter/CT Check**. For details, see "[Setting Meter/CT Check](#)".



Figure 14-18 Setting meter for the inverter

#### 14.4.4 Connection of Two Meters

If you have another power generation device (such as an inverter) at home and wants to monitor both device, our inverter provides a Meter 2 Communication function to monitor the other power generation device.

#### NOTICE!

- For connecting CT and meter, or connecting two meters, prepare an RJ45 splitter adapter and a proper waterproof enclosure for it in advance.
- The device for monitoring the system (device at Meter 1 position) can be CT, direct-connected meter and CT-connected meter, but the device for monitoring the other power generation device (device at Meter 2 position) can only be meters, either direct-connected meter or CT-connected meter. The following diagrams use the connection of CT and direct-connected meter for example.

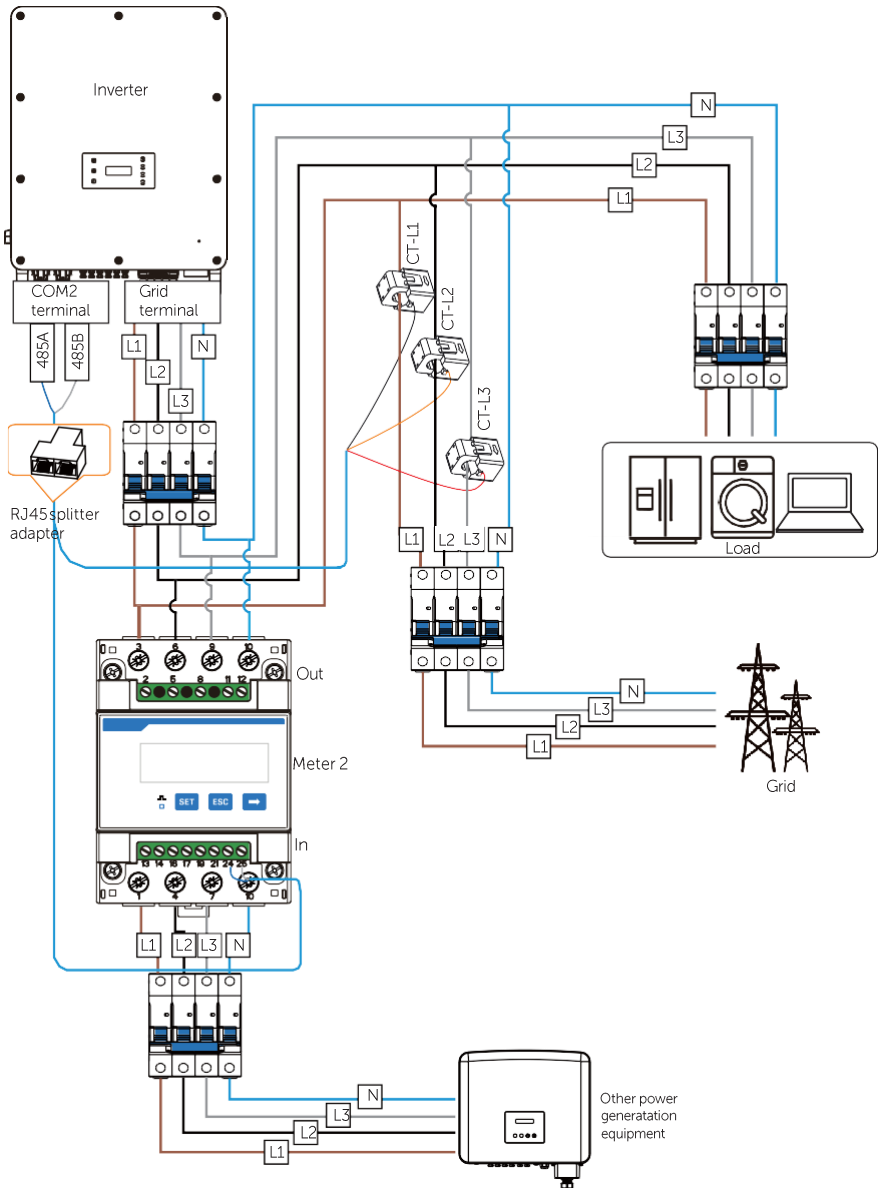

Figure 14-19 Connection diagram of CT and direct-connected meter

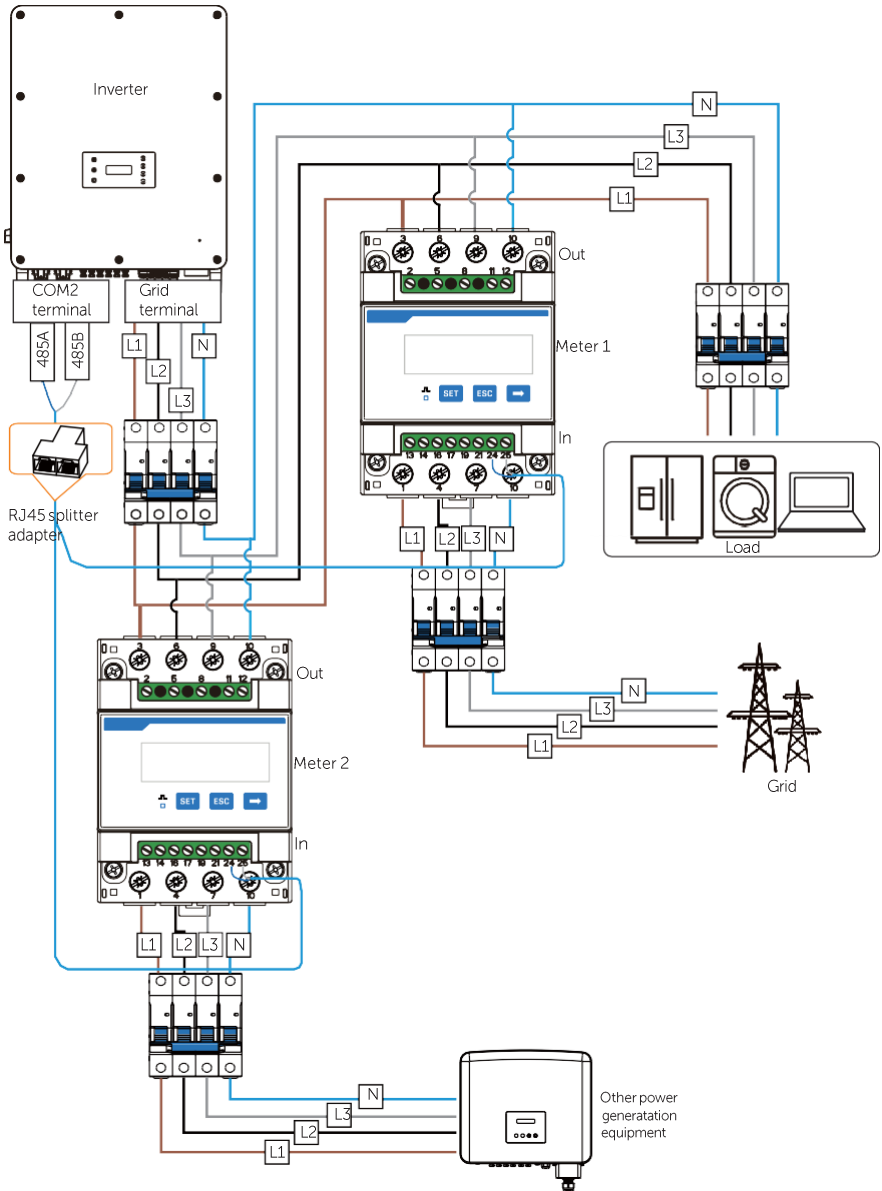

Figure 14-20 Connection diagram of two direct-connected meters

## Wiring procedure

**Step 1:** Follow the above steps to connect the meter, CT and inverter.

**Step 2:** Connect the RJ45 terminals to the RJ45 splitter adapter.

## Setting procedure

After connecting the CT and meter to the inverter, you need to set parameters on the inverter LCD before they can work normally for the system.

**Step 1:** Select **Advance Settings > Meter/CT Setting**.

**Step 2:** Set the Meter/CT:

- » Case 1: CT and Meter 2 are connected (CT for SolaX inverter, Meter 2 for another power generation device). CT is set by default. Check whether the address and direction of Meter2 are set based on actual connection.

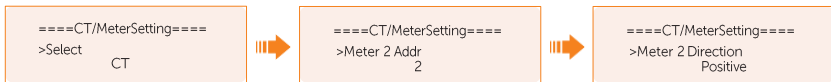

Figure 14-21 Selecting CT and set Meter2 data

- » Case 2: Meter 1 and Meter 2 are connected (Meter 1 for SolaX inverter, Meter 2 for another power generation device). Select **Meter** and enable the Meter function. Check whether the address and direction of Meter 1 and Meter 2 are set based on actual connection.

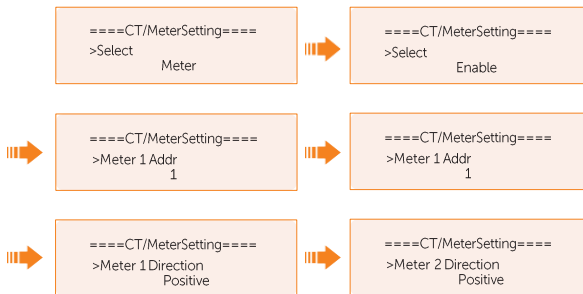

Figure 14-22 Selecting meter and set Meter 1 and Meter 2 data

**Step 3:** Set the CT type.



Figure 14-23 Setting the limits

### Related operation

#### Setting Meter/CT Check

- **Installation Check:** It is for checking whether the Meter/CT has been correctly connected. It is vital to the normal function of the whole system. Therefore, we recommend performing installation check after connecting the Meter/CT.

Select **Meter/CT Setting > Meter/CT Check**, and then enable **Installation Check**.

The system will perform Meter/CT check immediately after you enable it, and then automatically restores to the disabled status after the check completes.



- **Cyclic Check:** It is for periodically checking whether the Meter/CT is in good condition when the inverter is running.

Select **Meter/CT Setting > Meter/CT Check**, and then enable **Cyclic Check**.

Once Cyclic Check is enabled, the system will check the Meter/CT status periodically based on the defined cycle.



Figure 14-24 Checking Meter/CT status

# Contact Information



## UNITED KINGDOM

---



Unit C-D Riversdale House, Riversdale  
Road, Atherstone, CV9 1FA



+44 (0) 2476 586 998



service.uk@solaxpower.com



## TURKEY

---



Fevzi Cakmak mah. aslim cd. no 88 A  
Karatay / Konya / Turkiye



service.tr@solaxpower.com



## USA

---



3780 Kilroy Airport Way, Suite 200, Long  
Beach, CA, US 90806



+1 (408) 690 9464



info@solaxpower.com



## POLAND

---



WARSAW AL. JANA P. II 27. POST



+48 662 430 292



service.pl@solaxpower.com



## ITALY

---



+39 011 19800998



support@solaxpower.it



## PAKISTAN

---



service.pk@solaxpower.com



## AUSTRALIA

---



21 Nicholas Dr, Dandenong South VIC 3175



+61 1300 476 529



service@solaxpower.com.au



## GERMANY

---



Am Tullnaupark 8, 90402 Nürnberg,  
Germany



+49 (0) 6142 4091 664



service.eu@solaxpower.com



service.dach@solaxpower.com



## NETHERLANDS

---



Twekkeler-Es 15 7547 ST Enschede



+31 (0) 8527 37932



service.eu@solaxpower.com



service.bnl@solaxpower.com



## SPAIN

---



+34 9373 79607



tecnico@solaxpower.com



## BRAZIL

---



+55 (34) 9667 0319



info@solaxpower.com



## SOUTH AFRICA

---



service.za@solaxpower.com



**SolaX Power Network Technology (Zhejiang) Co.,  
Ltd.**

Add.: No. 278, Shizhu Road, Chengnan Sub-district, Tonglu County,  
Hangzhou, Zhejiang, China  
E-mail: [info@solaxpower.com](mailto:info@solaxpower.com)



320101120501